

Architectural
elements

CO
AV
R
O

IBAO



— A legacy of craftsmanship

1970 marked the birth of a vision. A vision of always innovating, always transforming. Pushing the boundaries of material science. For over fifty years, our passion for innovation has driven us from crafting ornate decor to pioneering technology materials in the industry, to Duropolymer. Always seeking to infuse the enduring with the revolutionary.

With each turn of the calendar, we — at Orac — have transcended our original identity. From our genesis as Orac to our expansion into Orac Decor, our journey now brings us back to where it all began: Orac, coming full circle. We are more than artisans of decor; we are pioneers, visionaries, storytellers of interior.

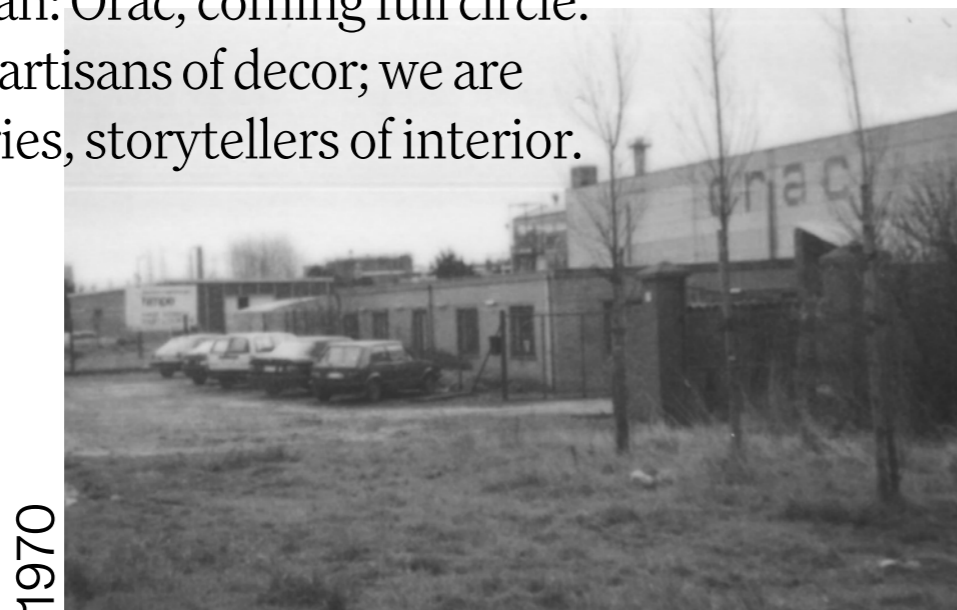

Start of Ostend Research and Application Company

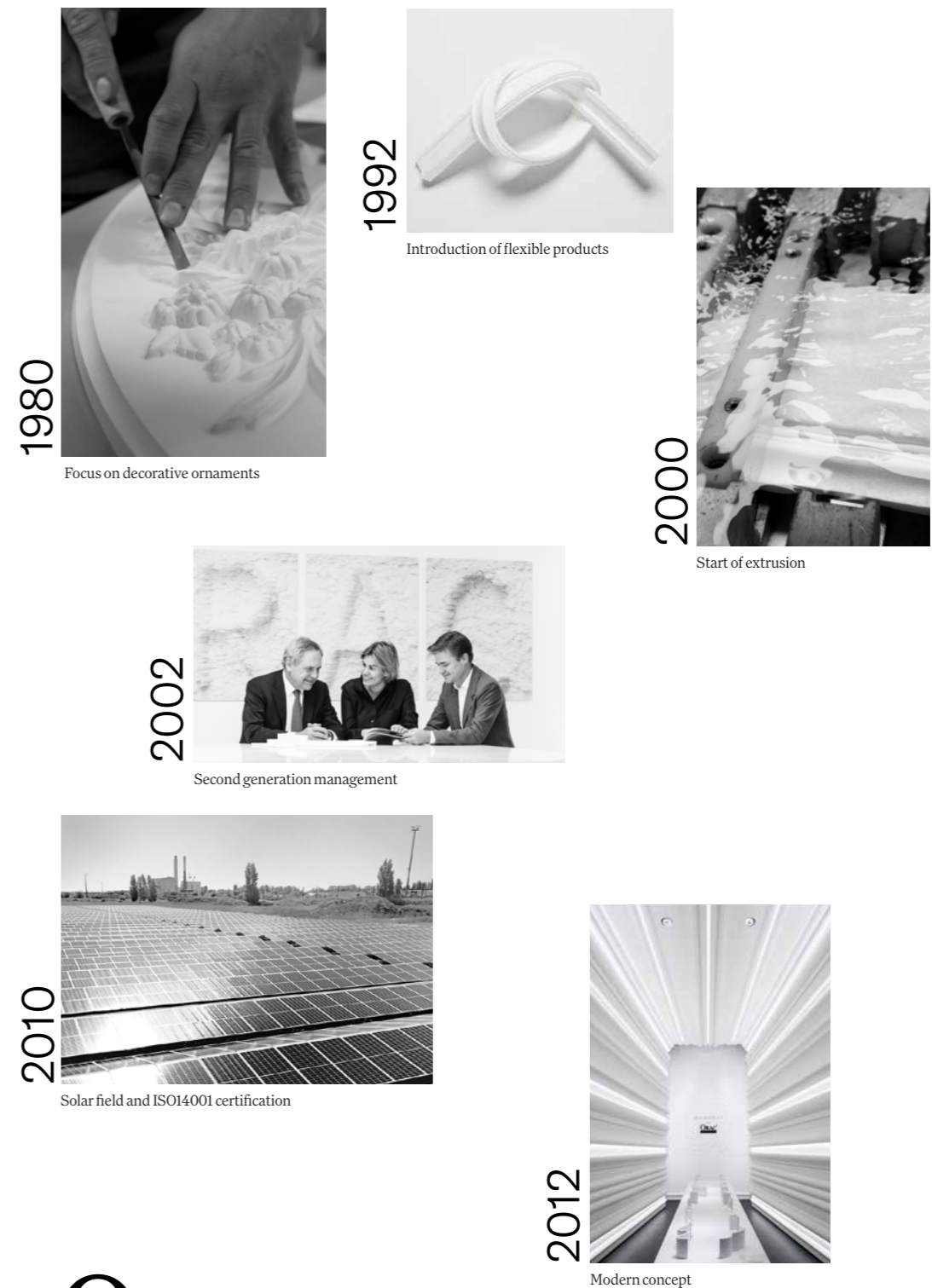

1980

Focus on decorative ornaments

1992

Introduction of flexible products

2000

Start of extrusion

2002

Second generation management

2010

Solar field and ISO14001 certification

2012

Modern concept

ORAC

We shed our old skin — Orac Decor — to emerge simply as Orac, a name that encapsulates our essence and our expansive vision for the future.

UA —

1970 рік став початком нової філософії. Бачення нових інновацій, потреба в трансформації, розширення меж науки про матеріали. Понад п'ятдесят років наше прагнення до інновацій вело нас від створення вишуканого декору до новаторства в галузі технологічних матеріалів та розробки Duropolymer. Ми завжди прагнемо поєднати довговічність з новачками. Кожного року, ми — в Orac, — виходили за межі власної ідентичності. Наша подорож, яка почалася від заснування Orac до розширення в Orac Decor, замикає коло й повертає нас туди, де все почалося: до Orac. Ми не просто виробники декору — ми першопрохідці, візjonerи, дизайнери простору.

PL —

Rok 1970 był rokiem narodzin wizji. Wizja ciągłego wprowadzania innowacji, ciągłego przekształcania. Przesuwanie granic nauk o materiałach. Od ponad pięćdziesięciu lat nasza pasja do innowacji napędza nas do tworzenia ozdobnych dekoracji z pionierskich materiałów technologicznych w branży przemysłu na duropolimery. Zawsze szukamy tego, co trwałe i napędzane rewolucją. Z każdym obrotem kalendarza my — w Orac — przekraczamy naszą pierwotną tożsamość. Od naszej genezy jako Orac do naszej ekspansji na Orac Decor, nasza podróż prowadzi nas teraz z powrotem do miejsca, w którym wszystko się zaczęło: Orac zatacza koło. Jesteśmy czymś więcej niż rzemieślnikami dekoracji; jesteśmy pionierami, wizjonerami, gawędziarzami wewnątrz.

RO —

Anul 1970 a marcat nașterea unei viziuni. O viziune de a inova mereu, de a transforma mereu. Depășind limitele științei materialelor. Timp de peste cincizeci de ani, pasiunea noastră pentru inovație ne-a condus de la fabricarea de decorațiuni ornamentale până la materiale tehnologice de pionierat în industrie la Duropolymer. Căutând întotdeauna să imbinăm ceea ce este durabil cu ceea ce este revoluționar. Cu fiecare întoarcere a calendarului, noi - la Orac - am depășit identitatea noastră inițială. De la geneza noastră ca Orac până la extinderea noastră în Orac Decor, călătoria noastră ne aduce acum înapoi la locul unde a început totul: Orac, întorcându-ne la cercul complet. Suntem mai mult decât artizani ai decorului; suntem pionieri, vizionari, naratori ai spațiului.

CZ —

Rok 1970 znamenal zrod vize. Vize stále inovovat, neustále se transformovat. Posouvání hranic materiálové vědy. Již více než padesát let naší vášně pro inovaceni vedlo od výroby ozdobných dekorací k průkopnickým technologickým materiálům v průmyslu až k Duropolymeru. Vždy jsme se snažili spojit trvalé s revolučním. S každým otočením kalendáře jsme — v Oracu — překročili naši původní identitu. Od našeho zrodu jako Orac po naše rozšíření na Orac Decor, naše cesta nás nyní přivádí zpět tam, kde to všechno začalo: Orac, kruh se uzavírá. Jsme víc než jen výrobci dekorací; jsme průkopníci, vizionáři a vypravěči příběhů o interiéru.

At Orac, we've always believed that there are many sides to a wall, and we are committed to choosing the good one. In a world where design often feels transient, we've chosen a different path.

Sustainability goes beyond the use of recycled materials; it's about designing ideas that stand the test of time. We understand that true sustainability means creating products that remain relevant for generations, not just a few fleeting years.



— A commitment carved in walls

UA —
В Орас ми завжди вірили, що у стіни є багато сторін, і ми прагнемо обрати найкращу з них. У світі, де дизайн часто здається швидкоплинним, ми обрали інший шлях. Екологічність - це не тільки про використання перероблених матеріалів; це про розробку ідей, які витримують випробування часом. Ми розуміємо, що справжня сталість - це створення продуктів, які залишатимуться актуальними протягом поколінь, а не лише кількох швидкоплинних років.

RO —
La Orac, am fost dintotdeauna de părere că un perete are mai multe fațete și depunem toate eforturile pentru a o alege pe cea mai bună. Într-o lume în care designul are de multe ori o dimensiune trecătoare, noi am ales o cale diferită. Sustenabilitatea nu înseamnă doar folosirea de materiale reciclate, ci înseamnă să concepem idei care nu-și pierd valoarea cu trecerea timpului. Înțelegem faptul că sustenabilitatea adevărată înseamnă să creăm produse care continuă să fie relevante pentru generațiile viitoare, nu doar pentru câțiva ani.

PL —
W Orac wierzymy, że ściany mają wiele stron i jesteśmy zobowiązani do wybierania tej dobrej. W świecie, w którym design często wydaje się przemijający, wybraliśmy inną ścieżkę. Zrównoważony rozwój wykracza poza wykorzystywanie materiałów pochodzących z recyklingu; chodzi o projekty, które przetrwają próbę czasu. Rozumiemy, że prawdziwy zrównoważony rozwój oznacza tworzenie produktów, które pozostają aktualne dla wielu pokoleń, a nie będą dekoracją tylko przez kilka ulotnych lat.

CZ —
Ve společnosti Orac jsme vždy věřili, že stěna má mnoho stran, a rozhodli jsme se vybrat si tu dobrou. Ve světě, kde design často působí pomíjivě, jsme si zvolili jinou cestu. Udržitelnost přesahuje používání recyklovaných materiálů; jde o designové záměry, které obstojí ve zkoušce času. Chápeme, že skutečná udržitelnost znamená vytvářet produkty, které zůstanou relevantní pro celé generace, nikoliv jen pro několik pomíjivých let.



— Every wall is a blank canvas

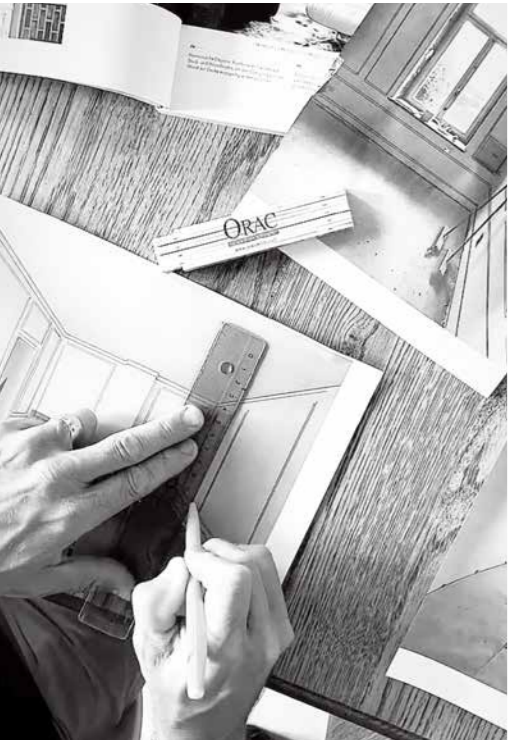

Where others see a flat surface, we see a world of possibilities. A clean primer, waiting for a little intervention. A bare base, in need of shape and dimension. A neutral support, asking to be someone's project and the centre of their attention. Which is all why, at Orac, we like to say we're visual artists of sorts — taking walls as a field of experimentation and at any time, seeking to honour their unique creative potential.

UA —

Там, де інші бачать рівну поверхню, ми вбачаємо світ можливостей. Це чисте полотно, яке чекає на свого митця. Проста основа, яка потребує форм та об'єму, невиразна, але з правильним підходом може стати витвором мистецтва та привернути увагу оточуючих. Саме тому, в компанії Orac, ми вважасмо себе свого роду візуальними художниками - сприймаємо стіни, як поле для експериментів, і прагнемо реалізувати їх унікальний творчий потенціал.

PL —

Tam, gdzie inni widzą płaską powierzchnię, my widzimy świat możliwości. Czysty podkład, czekający na małe zmiany. Kanwa, która potrzebuje, aby nadać jej kształtu i przestrzenności. Neutralne podłoże, które rwie się, aby stać się czymś projektem i być w centrum uwagi. Dlatego w Orac lubimy mówić, że jesteśmy pewnego rodzaju artystami wizualnymi - traktujemy ściany jako pole do eksperymentów i w każdej chwili staramy się uhonorować ich wyjątkowy potencjał twórczy.

RO —

Unde alții văd doar o suprafață plană, noi vedem posibilități nenumărate. Un grund curat, ca o pânză care așteaptă doar intervenția pictorului. O bază simplă, care are nevoie doar de formă și dimensiune. Un suport neutru, care abia așteaptă să devină, pentru cineva, un proiect de suflet și centrul atenției. Iată de ce, la Orac, ne place să spunem despre noi că suntem, într-un fel, artiști vizuali. Pereții sunt, pentru noi, o suprafață cu care ne putem „juca” și apreciem potențialul lor creativ unic.

CZ —

Tam, kde ostatní vidí hladký povrch, my vidíme svět možností. Čistý podklad, který čeká na malý zásah. Holý základ, který potřebuje tvar a rozměr. Neutrální základ, který chce být něčím projektem a středem pozornosti. Ve společnosti Orac proto rádi říkáme, že jsme svým způsobem vizuální umělci - bereme stěny jako prostor pro experimentování a v každém okamžiku se snažíme ctít jejich jedinečný tvůrčí potenciál.





Whether it's a touch of the contemporary or a nod to the classics, each of our products is a chameleon, adept at taking on the character you desire. Here are some glimpses into the myriad of ways our products can animate, define and transform interiors.

Every setting, every angle reveals new potential. A new story to be told.

Unexpected possibilities

UA —
Незалежно від того, чи це дотик до сучасності, чи погляд у сторону класики, кожен наш продукт — це хамелеон, який допоможе створити бажаний ефект. Ми хочемо з вами поділитися незліченною кількістю варіантів того, як наша продукція може надавати характеру, оживляти та видозмінювати простір. Кожне місце, кожен куток розкриває новий потенціал. Нову історію, яку ми хочемо розповісти.

PL —
Niezależnie od tego, czy chodzi o odrobinę współczesności, czy o ukłon w stronę klasyki, każdy z naszych produktów jest kameleonem, który potrafi wywrzeć pożądany efekt. Z przyjemnością prezentujemy niezliczone możliwości, dzięki którym nasze produkty mogą ożywiać, definiować i przekształcać przestrzenie. Każde ustawienie, każdy kąt ujawnia nowy potencjał. Nowa historia, którą chcemy opowiedzieć.

RO —
Fie că este vorba de o tușă contemporană sau de o trimitere la stilul clasic, fiecare dintre produsele noastre este cameleonic, adoptând cu ușurință caracterul dorit de dvs. Ne face plăcere să ilustrăm multitudinea de modalități în care produsele noastre pot aduce la viață interioarele, în care le pot defini și transforma. Fiecare loc, fiecare unghi este încărcat de potențial. Este o nouă poveste care abia așteaptă să fie spusă.

CZ —
Každý z našich produktů je chameleonem, který dokáže převzít charakter, jaký si přejete, ať už se jedná o nádech moderny nebo klasiky. Rádi vás seznámíme s nespočtými způsoby, jakými mohou naše produkty oživit, definovat a proměnit prostor. Každé prostředí, každý úhel pohledu odhaluje nový potenciál. Nový příběh, který je třeba vyprávět.

Content

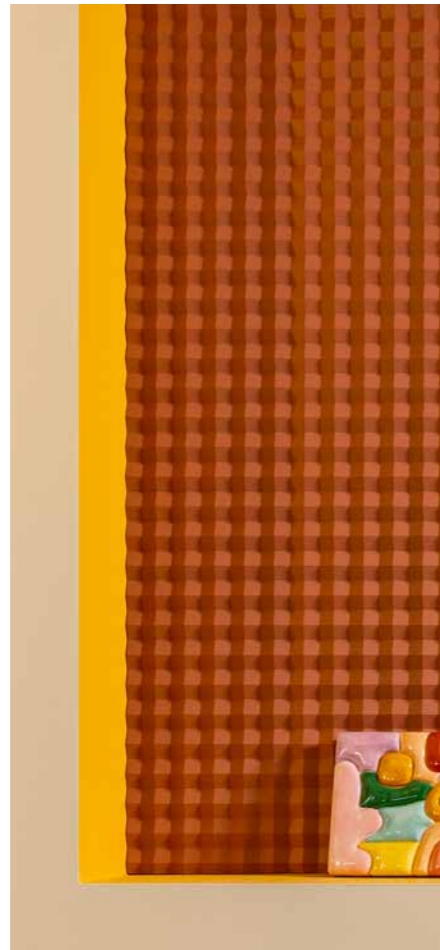

EN –

9 Unexpected possibilities

- 12 About today
- 22 Uncut modern
- 32 Vibrant allure
- 44 Essential still

57 Products

- 58 Materials
- 62 Product Overview
- 64 — 01 Cornice mouldings
- 92 — 02 3D Wall covering
- 108 — 03 Skirting boards
- 122 — 03 Panel mouldings
- 134 — 05 Indirect lighting
- 148 — 06 Deco elements
- 158 — 07 The perfect finish
- 162 — 08 Flexible products

UA –

9 Несподівані можливості

- 12 Про сьогоднішнє
- 22 Нерозрізаний модерн
- 32 Яскрава принада
- 44 Все ще значущі

57 Продукція

- 58 Матеріали
- 62 Огляд продукції
- 64 — 01 Карнизи
- 92 — 02 Стінові 3D-панелі
- 108 — 03 Плінтуси
- 122 — 04 Молдинги
- 134 — 05 Профілі для LED-освітлення
- 148 — 06 Декоративні елементи
- 158 — 07 Бездоганний результат
- 162 — 08 Гнучкі профілі

PL –

9 Nieoczekiwane możliwości

- 12 O dzisiaj
- 22 Nieskazitelna nowoczesność
- 32 Wibrujący urok
- 44 Nadal niezbędny

57 Produkty

- 58 Materiały
- 62 Przegląd Produktów
- 64 — 01 Gzymsy
- 92 — 02 Panele 3D
- 108 — 03 Listwy przypodłogowe
- 122 — 04 Profile ścienne
- 134 — 05 Listwy oświetleniowe
- 148 — 06 Elementy dekoracyjne
- 158 — 07 Idealne wykończenie
- 162 — 08 Produkty elastyczne

RO –

9 Posibilități neașteptate

- 12 Despre prezent
- 22 Modernitate neșlefuită
- 32 Un farmec plin de viață
- 44 Încă esențiale

57 Produse

- 58 Materiale
- 62 Rezumatul produselor
- 64 — 01 Cornise
- 92 — 02 Panouri decorative 3D
- 108 — 03 Plinte
- 122 — 04 Brauri
- 134 — 05 Iluminat indirect
- 148 — 06 Elemente decorative
- 158 — 07 Finisarea perfecta
- 162 — 08 Produse flexibile

CZ –

9 Nečekané možnosti

- 12 O dnešní době
- 22 Moderna bez stříhu
- 32 Živý půvab
- 44 Stále to podstatné

57 Produkty

- 58 Materiály
- 62 Přehled produktů
- 64 — 01 Stropní lišty
- 92 — 02 3D Nástěnné obložení
- 108 — 03 Podlahové lišty
- 122 — 04 Lemovací lišty
- 134 — 05 Nepřímé osvětlení
- 148 — 06 Dekorativní prvky
- 158 — 07 Perfektní zakončení
- 162 — 08 Ohebné Produkty

About today

At times, the modern is inclined to the here and now. Freed from the transience of fashion, it reveals a classic for the future. We are delighted to see it happen. The legacy of an era is revisited to create something new.

UA –

Іноді сучасність тяжіє до сьогодення. Звільнившись від швидкоплинності моди, відкривається майбутнє до класики. Ми раді за цим спостерігати. Спадщина епохи перероджується, щоб створити щось нове. Нота сміливості в знак поваги до сьогодення і майбутнього.

RO –

Uneori, spiritul modern tinde spre momentul prezent. Eliberat de caracterul temporar al modei, acesta devine un clasic al viitorului. Suntem cu adevărat încântați când asistăm la acest proces. Moștenirea unei epoci este reinterpretată pentru a crea ceva nou. O notă temerară, un omagiu adus prezentului și viitorului.

PL –

Czasami to, co jest nowoczesne, wpisuje się w obecną epokę. Nowoczesność uwolniona od ulotnej natury mody, odsłania ponadczasową esencję na przyszłość. Cieszymy się, że możemy być świadkami tego zjawiska.

Dziedzictwo epoki powraca, aby stworzyć coś innowacyjnego. Odważny gest oddaje hołd zarówno teraźniejszości, jak i przyszłości.

CZ –

Modernost se občas přiklání k proudu. Osvobozena od pomíjivosti módy odhaluje klasiku pro budoucnost. Jsme rádi, že se to děje. Znovu se vracíme k odkazu jedné éry, abychom vytvořili něco nového. Odvážný dotek vzdávající hořd současnosti a zítřku.



1. C990 p.77 2. CX188 p.142 3. PX209 p.131 4. W217 p.99 5. W218 p.99 6. SX182 p.111

UA —
Білий, в поєднанні з основними
кольорами, — смілива та
контрастна взаємодія.

PL —
Biel spotyka się z podstawowymi
kolorami: odważna, kontrastowa gra.

RO —
Albul se îmbină cu culorile primare:
o interacțiune îndrăzneță, un joc
al contrastelor.

CZ —
Bílá se setkává v odvážné a kontrastní
souhře se základními barvami.

ORAC

Unexpected possibilities

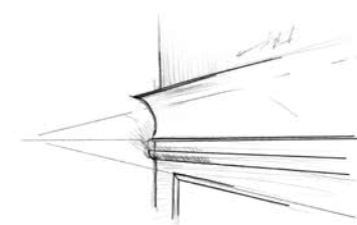

C990 INFINITY + CX188

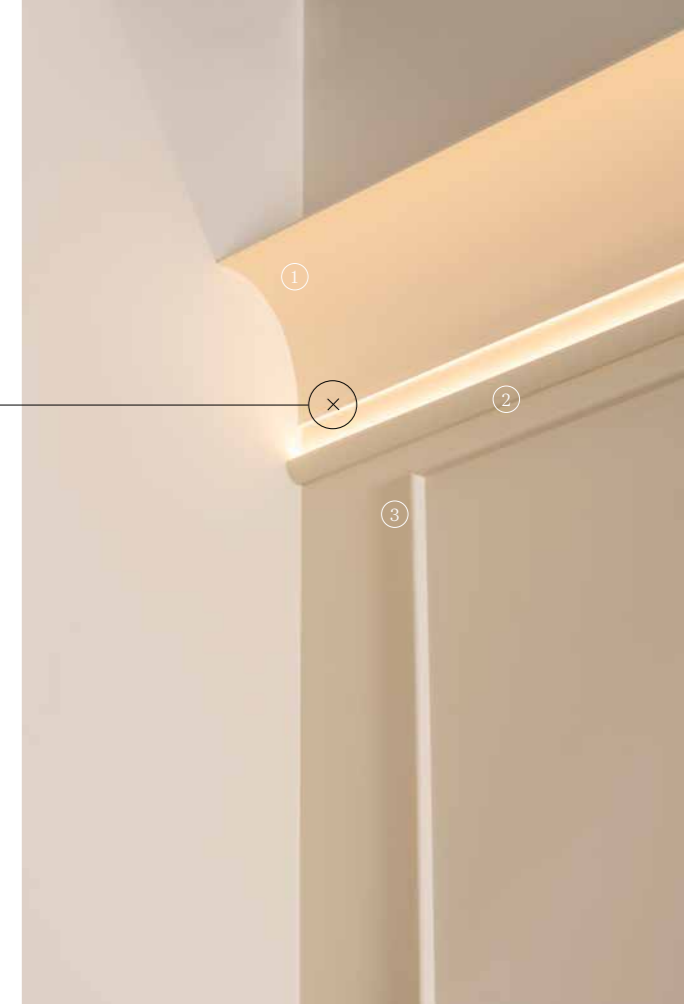

1. C990 p.77 2. CX188 p.142 3. PX209 p.131

3. PX209 p.131



White meets
primary colours:
a bold, contrasting
interplay.

About today

UA —
Великі 3D-форми створюють
сміливий та естетичний простір.

PL —
Duże kształty 3D odważnie
tworzą estetykę przestrzeni.

RO —
Formele tridimensionale voluminoase
creează un interior cu caracteristici
îndrăznețe.

CZ —
Velké 3D tvary vytvářejí
odvážně estetický prostor.

1. W115 p.102

Large 3D shapes
carve out a boldly
aesthetic space.

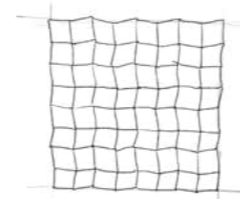
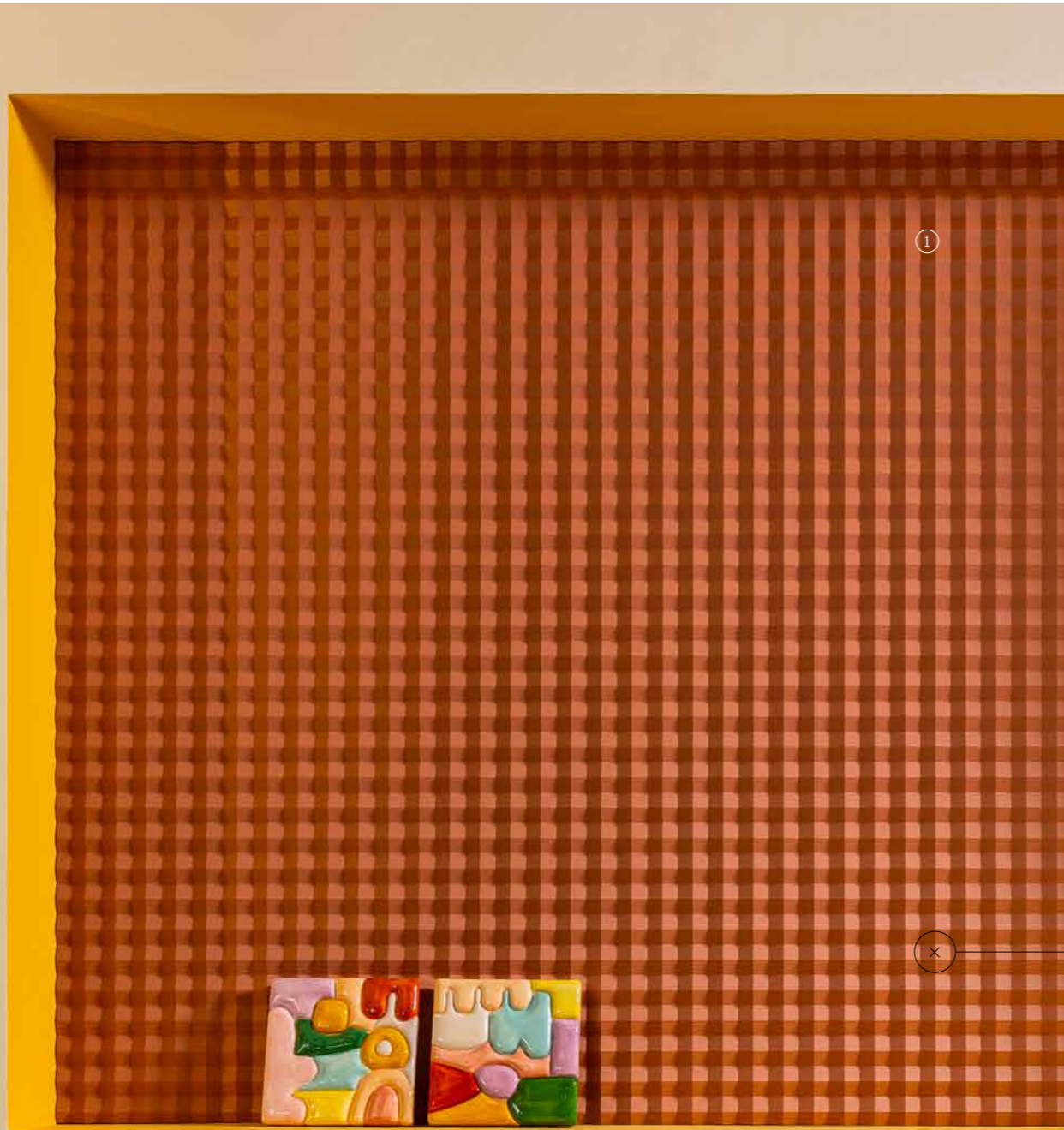

W115 SLOPE

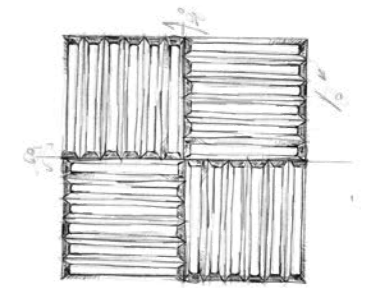

W218 QUILT



2. W218 p.99 3. W217 p.99 4. SX182 p.111

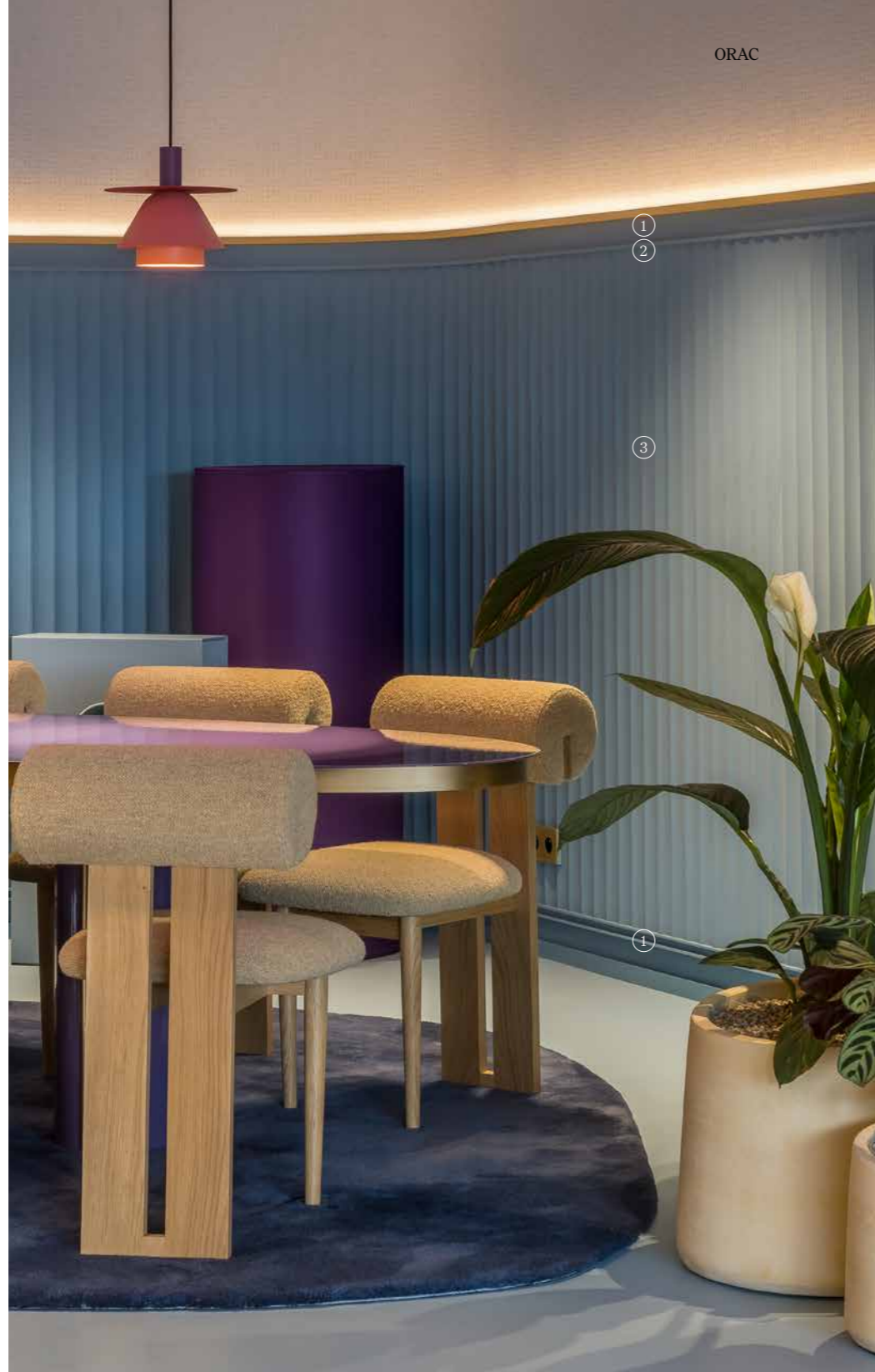

ORAC

Unexpected possibilities

Eclectic blend of rounded 3D panels and vivid colour contrasts.

¹ CX190 | CX190F p.142 ² SX194 | SX194F p.131 ³ W114 | W114F p.98



¹ CX190 | CX190F p.142 ² SX194 | SX194F p.131 ³ W114 | W114F p.98

UA —
Еклектичне поєднання округлих 3D-панелей та яскравих кольорових контрастів.

PL —
Eklektyczne połączenie zaokrąglonych paneli 3D i żywych kontrastujących barw.

RO —
Un amestec eclectic de panouri tridimensionale rotunjite și contraste cromatice puternice.

CZ —
Eklektická směs zaoblených 3D panelů a výrazných barevných kontrastů.

¹ W110 p.96

Each room a vibrant canvas with 3D textured walls, daringly immersive. We invite you to dive in and explore.



¹ W110 p.96

¹ W110 p.96



UA —
Кожна кімната — це яскраве полотно з 3D-текстурними стінами, які зухвало занурюють у свою атмосферу. Запрошуємо вас зануритись разом із нами.

PL —
Każdy pokój to tętniące życiem płótno z teksturowanymi ścianami 3D, odważnie immersyjne. Zachęcamy do wkrócenia do naszego świata, jeśli tylko tego zapragniesz.

RO —
Camerile se transformă în tot atâtea pânze cu pereți tridimensionali texturați, care creează o atmosferă captivantă. Vă invităm să pătrundeți în acest univers, dacă vă doriți aceasta.

CZ —
Každá místnost je živým plátnem s 3D texturou na stěnách, které vás odvážně pohltí. Pokud chcete, můžete se ponořit.



Uncut modern

Unexpected possibilities

UA —

Нас постійно вражають унікальні досягнення сучасності. Прогресивність розуму. Сподіб, у який скромність поєднується з тонкою величчю. Ми з любов'ю створюємо чисті лінії, цінуємо мінімалістичний шарм і бруталну зухвалість. Любов до сучасності спонукає нас бути уважними до деталей.

RO —

Realizările unice ale epocii moderne ne-au impresionat întotdeauna și continuă să o facă. Vederile progresiste. Felul în care se îmbină simplitatea cu măreția subtilă. Urmărim cu incântare cu privirea liniile epurate, apreciem eleganța minimalistă și îndrăzneala brutalistă. Pasiunea noastră pentru modernitate ne îndeamnă să fim mereu atenți la detalii.

PL —

Nieustannie inspirują nas wyjątkowe osiągnięcia współczesności — postępowość umysłu, harmonijne połączenie skromności z subtelną wielkością. Z lubością śledzimy czyste linie, stawiamy na minimalistyczny wdzięk i doceniamy brutalistyczną śmiałość. Nasze przywiązanie do nowoczesności sprzyja dbałości o szczegóły.

CZ —

Neustále nás dojmají výjimečné úspěchy moderní doby. Progresivita mysli. Způsob, jakým se skromnost snoubí s jemnou vznešeností. S láskou sledujeme čisté linie, oceňujeme minimalistický půvab a brutalistní odvahu. Naše slabost pro modernost podporuje naši pozornost věnovanou detailům.

We are perpetually moved by the singular achievements of the modern age. The progressiveness of the mind. The way modesty blends with subtle grandeur. We lovingly trace clean lines, value minimalist grace and brutalist audacity. Our affection for modernity encourages our attentiveness to detail.

1. P9900 p.126 2. SX194 p.131 3. SX180 p.114



UA —
Плавні лінії, кутові форми та мінімалістична елегантність у сучасній гармонії.

PL —
Smukłe linie, kanciaste kształty i minimalistyczna elegancja w pełnej harmonii.

RO —
Linii curate, forme unghiulare și eleganță minimalistă, toate se contopesc pentru a crea armonia modernă.

CZ —
Elegantní linie, hranaté tvary a minimalistická elegancie v moderní harmonii.

Sleek lines, angular shapes and minimalist elegance in modern harmony.

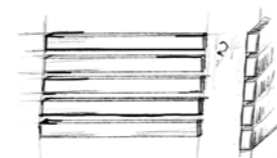

W111 BAR



- 4. C391 p.79
- 5. C393 p.79
- 6. W111 p.101
- 7. W116 p.101
- 8. W119 p.101
- 9. CX190 p.116



ORAC

Unexpected possibilities

Modern Art Deco vibe:
an understated,
layered elegance.

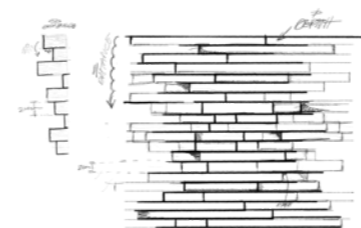

W216 MATRIX

7. C392 p.79 8. C390 p.79 9. P7070 p.126 10. SX180 p.114

- 1. C391 p.79
- 2. C393 p.79
- 3. CX190 p.130
- 4. W216 p.102
- 5. SX207 p.118



P7070

Unicri modern

UA —
Сучасна атмосфера арт-деко
— це стримана, багатшарова
елегантність.

PL —
Nowoczesny klimat art deco:
subtelna, wielowarstwowa elegancja.

RO —
Influențe art deco moderne: eleganță
subtilă, care se dezvăluie treptat.

CZ —
Moderní atmosféra Art Deco:
nenápadná, vrstvená elegancie.

Symmetry
reimagined:
U-profiles dance on
walls and gracefully
embrace ceilings.



¹ CX190 p.116

ORAC

Unexpected possibilities

UA —
Переосмислена симетрія: U-подібні профілі танцюють на стінах і витончено обіймають стелю.

PL —
Symetria w nowej odsłonie: Profile w kształcie litery U tańczą na ścianach i wdzięcznie otulają sufity.

RO —
Simetrie reinventată: profiluri în U care pun în valoare pereții și care evidențiază elegant plafoanele.

CZ —
Symetrie v novém pojetí: U-profilů tančí na stěnách a ladně objímají stropy.



² CX190 | CX190F p.116



³ CX190F p.116



¹ SX180 p.114

Stepped lines
translate a modern
Art Deco vision from
floor to ceiling.

¹ SX180 p.114 ² CX188 p.00 ³ C393 p.79 ⁴ C394 p.79 ⁵ C391 p.79

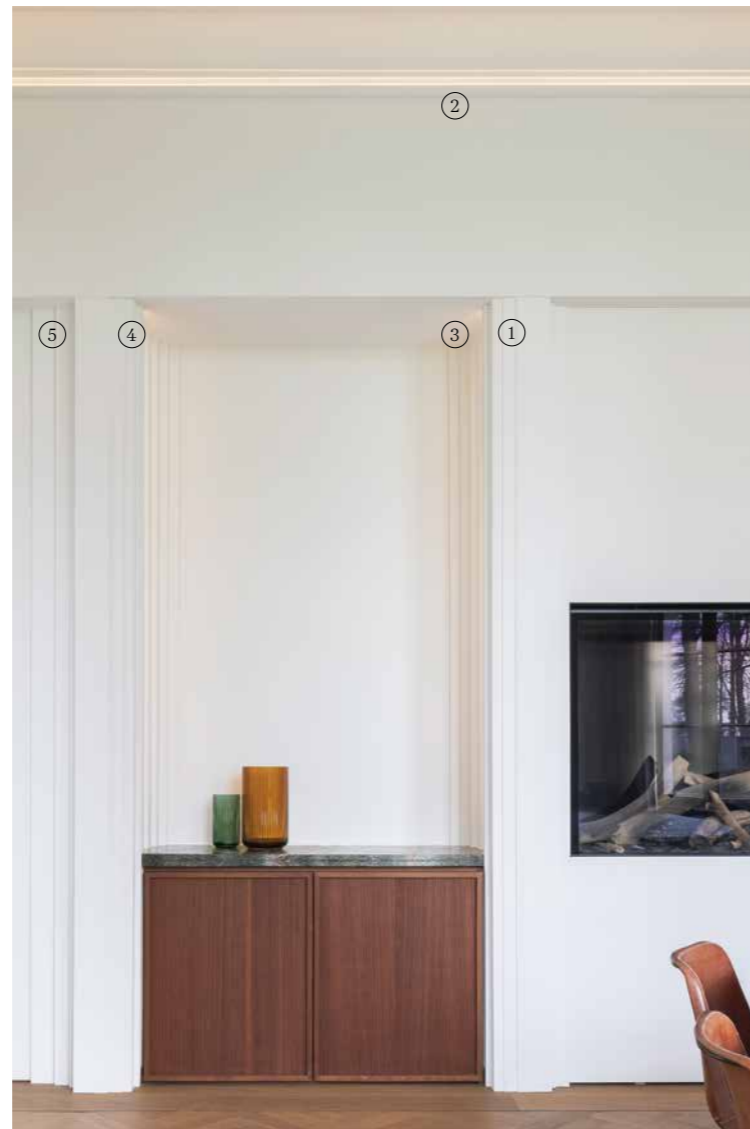

UA —
Ступінчасті лінії передають
сучасне бачення ар-деко від
підлоги до стелі.

PL —
Schodkowe linie wyrażają
nowoczesną wizję art deco
od podłogi po sufit.

RO —
Liniiile care formează trepte ilustrează
viziunea art deco pe verticală, de la
pardoseală până la plafon.

CZ —
Stupňovité linie odrážejí
moderní vizi Art Deco od
podlahy až ke stropu.



⁶ C991 + 2xP9900 p.77 ⁷ CX188 p.142

Vibrant allure

ORAC

Unexpected possibilities

UA —

Ми любимо занурюватися у світ мистецьких сюрпризів, де класична елегантність поєднується зі сміливими, зухвалими поворотами, створюючи неповторний досвід. Царство несподіванок, де вишуканість зустрічається з примхам на святі творчості.

PL —

Pragniemy zanurzyć się w świecie artystycznych niespodzianek, w którym klasyczna elegancja spotyka się z odważnymi, bezkompromisowymi zwrotami akcji, tworząc jedyne w swoim rodzaju doznanie. To królestwo nieoczekiwanego, gdzie elegancja spotyka się z fanaberią w imię kreatywności.

RO —

Ne face plăcere să pătrundem într-un univers plin de surprize ingenioase, în care stilul clasic și eleganța se îmbină cu detaliile îndrăznețe, temerare, creând astfel o experiență unică. Un spațiu surprinzător, unde rafinamentul și fantezia se împletesc într-un omagiu adus creativității.

CZ —

Rádi vstupujeme do světa uměleckých překvapení, kde se klasická elegancie setkává s odvážnými a smělymi zvraty a vytváří jedinečný zážitek. Říše neočekávaného, kde se sofistikovanost setkává s rozmarností a oslavuje kreativitu.

We love to step into a world of artful surprises, where classic elegance meets daring, audacious twists, creating a one-of-a-kind experience. A realm of the unexpected, where sophistication meets whimsy in a celebration of creativity.

1. C332 p.74 2. W214 p.96 3. W215 p.96 4. SX138 p.113

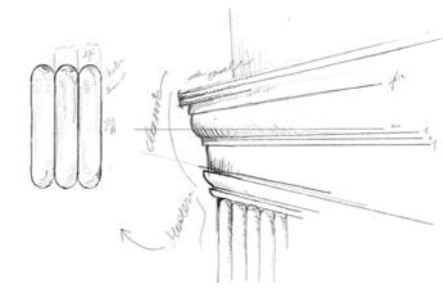

C332 NOBLESSE
W214 HILL BEAD XL

UA —
Пустотливе зіткнення
текстури та кольору;
яскраві візерунки та
глибокі відтінки створюють
несподівану гармонію.

PL —
Figlarna mieszanka tekstur
i kolorów; żywe wzory i
głębokie kolory tworzą
zaskakującą harmonię.

RO —
O îmbinare a texturilor și
culturilor, cu modele pline de
viață și nuanțe intense care
creează o armonie neașteptată.

CZ —
Rozpustilý střet textur a barev;
živé vzory a hluboké odstíny
vytvářejí nečekanou harmonii.

A mischievous collision
of texture and colour;
vibrant patterns and
deep hues crafting an
unexpected harmony.



1. C332 p.74 2. W215 p.96 3. SX138 p.113 4. W214 p.96 5. W110 p.96 6. PX209F p.131 7. WX210F p.95 8. WX211F p.95



2. W215 p.96 3. SX138 p.113 4. W214 p.96



Walls oozing with
glamour and abundance,
beckoning you into
their captivating
design narrative.

UA —
Стіни, наповнені розкішно і
достатком, приваблюють вас
своїм чарівним дизайном.

PL —
Ściany emanujące przepychem i
obfitością, zachęcają do zapoznania
się z ich urzekającą narracją.

RO —
Pereți care denotă extravaganța
și abundența, care vă cheamă în
universul designului lor captivant.

CZ —
Stěny oplývající půvabem a hojností,
které vás lákají do svého podmanivého
designového příběhu.



¹ PX175 p.129 ² P8030 p.124

UA —
Неприборкана творчість розквітає в розкішному поєднанні кольору та хитромудрого дизайну.

PL —
Efekt kontrastu: gdzie ozdobne detale i spokojne odcienie znajdują śmiały wyraz.

RO —
Un studiu al contrastelor, în care se manifestă detaliile bogate alături de tonurile senine și liniștite.

CZ —
Kontrastní obrazec, kde se odvážně projevují zdobné detaily a klidné odstíny.

A canvas of contrast:
where ornate details
and serene hues find
daring expression.



¹ PX175 p.129 ² P8030 p.124



³ P3020 p.125 ⁴ P3020A p.133 ⁵ P8050 p.124



1- PX120 p.129 2- P4020 p.124



3- C305 p.70 4- C307A p.70 5- C211 p.70

Untamed creativity blooms in a lavish fusion of colour and intricate design.



1- PX120 p.129 2- P4020 p.124 3- C305 p.70 4- C307A p.70 5- C211 p.70 6- DX170-2300 p.154 7- D330LR p.154

UA—
Картина контрасту: пишні деталі та спокійні відтінки знаходять сміливе вираження.

PL—
Nieokiełznana kreatywność rozkwita w bogatej fuzji kolorów i misternego desingu.

RO—
Creativitatea nedomolită își găsește expresia potrivită într-un spațiu în care culorile și designul complex se contopesc.

CZ—
Nezkrotná kreativita rozkvétá v bohaté kombinaci barev a složitého designu.

Whenever you fancy a change,
our products are ready for
a repaint.



1- PX120 p.129 2- P4020 p.124 3- C305 p.70 4- C307A p.70 5- C211 p.70

UA —
Якщо ви забажаєте змін,
наші вироби завжди можна
перекрасити.

PL —
Gdy tylko zapragniesz zmiany,
nasze produkty są gotowe do
przemalowania.

RO —
Ori de câte ori doriți o schimbare,
produsele noastre sunt gata pentru
a fi revopsite.

CZ —
Kdykoli budete mít chuť na
změnu, naše výrobky jsou
připraveny k přetření.



Essential still

ORAC

Unexpected possibilities

We love to embrace the timeless charm of bygone eras as it speaks fluently in the language of today. A demonstration of how classic forms can be reinterpreted to remain ever-relevant.

UA —

Ми в захваті, коли шарм минулих епох може вільно розмовляти мовою сьогодення. Це демонстрація того, як класичні форми можуть бути переосмислені, щоб залишатися завжди актуальними.

PL —

Uwielbiamy momenty, w których niezaprzeczalny urok minionych epok płynnie łączy się ze współczesnym językiem. Jest to dowód na to, jak klasyczne formy mogą być reinterpretowane, zapewniając ich ciągłą aktualność.

RO —

Nu există nimic mai pasionant decât acele momente în care timpurile trecute prind glas în prezent. O demonstrație a modului în care formele clasice pot fi reinterpretate, pentru a nu-și pierde niciodată relevanța.

CZ —

Jsmе tak rádi, když nadčasový půvab minulých epoch mluví plynně jazykem dneška. Ukázka toho, jak lze klasické formy nově interpretovat, aby zůstaly stále aktuální.

¹-C343 p.66 ²-P8020 p.124 ³-P4020 p.124 ⁴-SX206 p.113



UA—

Вишукані елементи на стіні, розташовані в довільній послідовності, випромінюють рівновагу та спокій.

PL—

Wyrafinowane elementy ułożone w przemyślanej sekwencji na ścianie emanują poczuciem równowagi i spokojnej obecności.

RO—

Elemente rafinate care se succed pe perețe, nicideată la întâmplare, sugerând o prezență echilibrată și calmă.

CZ—

Rafinované prvky v libovolném pořadí na stěně vyzařují rovnováhu a klidnou přítomnost.

C343 HERITAGE

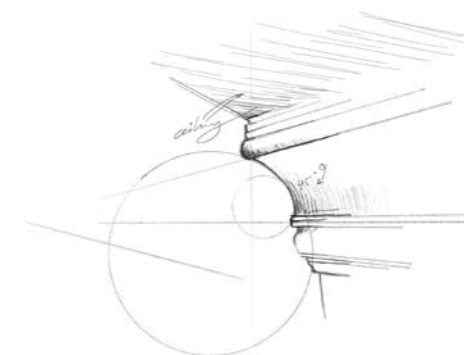

Refined elements,
in a far from arbitrary
sequence on the wall,
exude balance and
discrete presence.





ORAC

Unexpected possibilities

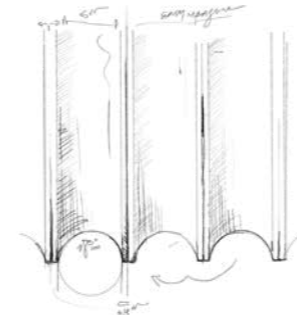

W109 VALLEY

Poised grace in every line,
creating an atmosphere of
calm sophistication.

1. W109 p.98 2. P9010 p.124 3. P9050 p.126



1. W109 p.98 2. P9010 p.124 3. P9050 p.126 4. SX155 p.112

UA —
Стримана грація в кожній лінії,
що створює атмосферу спокійної
вишуканості.

PL —
Łagodność w każdej linii, tworząca
atmosferę cichego wyrafinowania.

RO —
Grație și echilibru în fiecare linie,
care creează o atmosferă plină de
rafinament și seninătate.

CZ —
Vyrovnaný půvab v každé linii vytváří
atmosféru klidné sofistikovanosti.

Towering ceilings crowned with grand cornices offer a narrative of timeless opulence.



1. P8050 p.124



3. C305 p.70 4. C307A p.70 5. C211 p.70

2. PX175 p.129 3. C305 p.70 4. C307A p.70 5. C211 p.70 6. P8030 p.124 7. SX191 p.115



UA —
Високі стелі, увінчані величними карнизами, розповідають нам про позачасову розкіш.

PL —
Wysokie sufity zwieńczone okazałymi gzymsami tworzą narrację ponadczasowego bogactwa.

RO —
Plafoane înalte, încheiate cu cornișe grandioase, expresie a unei opulențe atemporale.

CZ —
Vysoké stropy korunované honosnými profily vyprávějí o nadčasovém bohatství.



1. C343 p.66 2. P8020 p.124 3. P4020 p.124 4. SX191 p.115 5. DX170-2300 p.154 6. D330LR p.154

Grandeur in every detail, framed by a bold monochromatic use of saturated colours.



1. C343 p.66 2. P8020 p.124 3. P4020 p.124 4. SX191 p.115

UA —
Велич у кожній деталі, обрамлена сміливим монохроматичним використанням насичених кольорів.

PL —
Wspaniałość w każdym detalu, otoczona odważnym monochromatycznym użyciem nasyconych barw.

RO —
Măreție până în cele mai mici detalii, evidențiată de culorile saturate, într-o execuție monocromatică.

CZ —
Velkolepost v každém detailu, rámovaná odvážným monochromatickým použitím sytých barev.

¹ P8030 p.124 ² CX160 p.89 ³ C332 p.74



Enhance our products with textured paint for an artisanal finish that adds depth and character to any room.

UA — Використуйте для фарбування виробів текстурну фарбу, це додасть глибини та характеру будь-якому приміщенню.

PL — Wzbogać nasze produkty farbą teksturowaną, aby uzyskać rzemieślnicze wykończenie, które doda głębi i charakteru każdemu pomieszczeniu.

RO — Îmbunătățiți produsele noastre cu vopsea texturată pentru un finisaj artizanal care adaugă profunzime și caracter oricărei încăperi.

CZ — Vylepšete naše produkty texturovanou barvou pro řemeslný povrch, který dodá hloubku a charakter každé místnosti.



Products

Discover our architectural elements, made for walls. Every product is an innovation with user ease in mind, designed to enhance and transform interiors. We propose a palette that matches styles and meets ideas. So that your walls can become the canvas for your imagination.

UA –
Відкрийте для себе наші стінові панелі. Кожен виріб — це, зручна у використанні інновація, створена для покращення та перевтілення інтер'єру. Ми пропонуємо палітру, яка поєднається з будь-яким стилем та допоможе втілити ваші ідеї. Ми перетворюємо стіни на простір для вашої фантазії.

PL –
Odkryj nasze elementy architektoniczne, stworzone do ścian. Każdy produkt jest innowacją, przygotowaną z myślą o wygodzie użytkownika oraz zaprojektowaną tak, aby ulepszać i przekształcać wnętrza. Proponujemy paletę, która pasuje do stylów i spełnia pomysły. Aby Twoje ściany mogły stać się płótnem dla Twojej wyobraźni.

RO –
Descoperiți elementele noastre arhitecturale, făcute pentru pereți. Fiecare produs este un inovație care are în vedere ușurința utilizatorului, concepute pentru a îmbunătăți și transforma interioarele. Vă propunem o paletă care se potrivește cu stilurile și vine în întâmpinarea ideilor. Pentru ca pereții dvs. să poată deveni pânza pentru imaginația dumneavoastră.

CZ –
Objevte naše architektonické prvky, vytvořené pro stěny. Každý produkt je inovace s myšlenkou na uživatelskou jednoduchost, navržený k vylepšení a transformaci interiéru. Nabízíme paletu, která odpovídá stylům a naplňuje nápady. Aby se vaše stěny mohly stát plátnem pro vaši představivost.



Materials

In-house engineered material compositions

ВИСОКОТЕХНОЛОГІЧНІ МАТЕРІАЛИ
MATERIAŁY TECHNICZNE
MATERIALE PROIECTATE INTELIGENT
KONSTRUKČNÍ MATERIÁLY

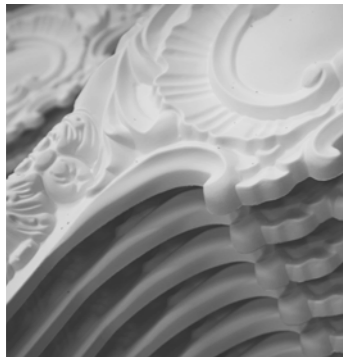

PUROTOUCH®

A high-quality, medium-density polyurethane that allows fine details.

Високоякісний матеріал середньої щільності, який дозволяє відтворити дрібні деталі — Wysokiej jakości, o dużej gęstości poliuretan pozwala uzyskać drobne szczegóły — Un poliuretan de înaltă calitate, de medie densitate, care permite detalii fine — Vysoce kvalitní polyuretan vysoké hustoty umožňuje jemné detaily

Detail Design ☆☆☆

Impact Resistance ☆☆☆

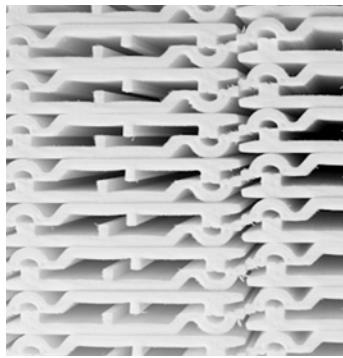

DUROPOLYMER®

An extruded and impact-resistant polymer based on a high-density polystyrene.

Екструдований ударостійкий полімер на основі полістиролу високої щільності — Tłoczony, odporny na uderzenia polimer powstały na bazie polistyrenu o wysokiej gęstości — Un polimer extrudat si rezistent la impact pe baza unui polistiren de inalta densitate. — Lisovaný, mechanicky odolný polymer na bázi hustého polystyrénu

Detail Design ☆☆☆

Impact Resistance ☆☆☆



DUROFOAM®

An extruded lightweight polymer based on a low-density polystyrene blend.

Екструдований легкий полімер на основі полістиролу низької щільності — Lekki, tłoczony polimer na bazie mieszanki polistyrenów o wysokiej gęstości — Un polimer extrudat usor pe baza unui polistiren de scazuta densitate — Lisovaný lehký polymer na bázi středně husté polystyrénové směsi

Detail Design ☆☆☆

Impact Resistance ☆☆☆



FLEX

A quality high-density flexible polyurethane.

Якісний еластичний поліуретан високої щільності — Formowany, wysokiej jakości elastyczny poliuretan o wysokiej gęstości — Un poliuretan flexibil de înaltă densitate de calitate — Kvalitní flexibilní polyuretan vysoké hustoty

Detail Design ☆☆☆

Impact Resistance ☆☆☆

READY TO PAINT

All of our products are ready to paint. Coloured end finishes on demand.

Усі наші вироби готові до фарбування — Wszystkie nasze produkty są gotowe do malowania. Kolory dostępne na życzenie — Toate produsele noastre sunt gata pentru vopsit. Culoare la cerere — Všechny naše výrobky jsou připraveny k okamžitému nátěru. Barvy na vyžádání



ПЕРЕВАГИ
ZALETY
AVANTAJE
VÝHODY

Advantages



DURABLE

Orac products are designed to last a lifetime. Smart design and high-end technology assure strong and water resistant products.

Продукція Orac розроблена, щоб слугувати вам якомога довше. Продуманий дизайн і передові технології забезпечують міцність і водостійкість виробів — Produkty Orac zostały zaprojektowane z myślą o wieloletniej trwałości. Przemysłany projekt i najnowocześniejsza technologia zapewniają wytrzymałość i wodoodporność naszych produktów — Produsele Orac sunt concepute să reziste pe viață. Designul inteligent și tehnologia de vârf asigură produse durabile, rezistente la apă — Produkty Orac jsou navrženy tak, aby vydržely po celý život. Inteligentní design a špičková technologie přináší mechanicky odolné a voděodolné produkty

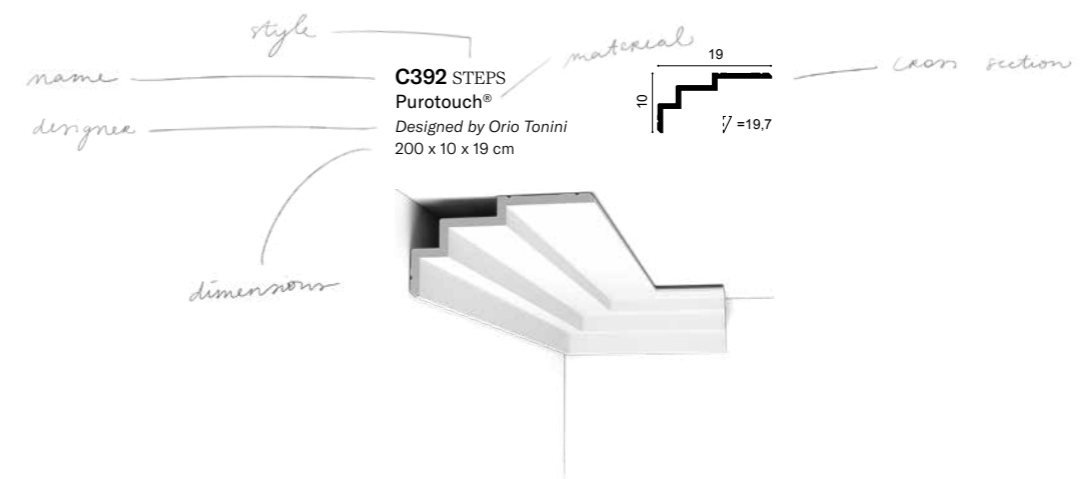

Legend

At Orac, our vision is to become restorative by 2050. This ambitious goal drives our material choices and operational practices, ensuring that every step we take not only minimizes environmental harm but actively contributes to ecological restoration. Since 2018 we have been making profound changes in the full lifecycle of our products. From selection and use of raw materials all the way to our production process.

— There are many sides to walls. We go for the good side.

UA —
В Орас ми прагнемо до 2050 року повністю відновити довкілля, яке зазнає негативного впливу від виробництва. Ця амбітна мета полягає у виборі матеріалів і методів виробництва: кожен наш крок не лише мінімізує шкоду для довкілля, а й активно сприяє його відродженню. З 2018 року ми докорінно змінюємо весь життєвий цикл нашої продукції - від вибору й використання сировини до виробничих процесів.
— Стіни мають багато сторін, і ми прагнемо обрати найкращу з них.

PL —
Naszą wizją w Orac jest odbudowa do roku 2050. Ten ambitny cel napędza nasze wybory materiałów i praktyki operacyjne, dążąc do minimalizowania szkód w środowisku poprzez aktywne przyczynianie się do odnowy ekologicznej. Od 2018 roku wprowadzamy głębokie zmiany w całym cyklu życia naszych produktów. Od wyboru i wykorzystania surowców, aż po proces produkcji.
— Ściany mają wiele stron. My stawiamy na tę dobrą.

RO —
La Orac, viziunea noastră este de a deveni restauratori până în 2050. Acest obiectiv ambițios ne determină să folosim alegerile materiale și practicile operaționale, asigurând că fiecărui pas pe care îl facem nu numai că minimizează daunele aduse mediului, ci contribuie în mod activ la refacerea ecologică. Începând cu anul 2018 am făcut schimbări profunde în întregul ciclu de viață al produselor noastre. De la selecția și utilizarea materialelor prime până la procesul nostru de producție.
— Pereții au mai multe laturi. Noi mergem pe latura bună.

CZ —
Naší vizí ve společnosti Orac je stát se obnovujícími do roku 2050. Tento ambiciózní cíl je hnacím faktorem při volbě našich materiálů a a provozních postupů, čímž zajišťujeme, že každý náš krok nejen minimalizuje poškození životního prostředí, ale aktivně přispívá k ekologické obnově. Od roku 2018 provádíme zásadní změny v celém životním cyklu našich výrobků. Od výběru a použití surovin až po náš výrobní proces.
— Stěny mají mnoho stran. My jdeme za tou dobrou stranou.



BIOCIRCULAR MATERIALS
Orac's designs merge recycled and bio-based materials, emphasizing sustainable innovation.



SUSTAINABLE OPERATIONS
Orac has been CO₂ neutral since 2021, working towards climate positivity by 2050.



BUILT TO LAST, BUILT RESPONSIBLY
Our durable products with a lasting lifetime support a sustainable, circular economy.



MORE THAN WALLS
Orac's commitment to sustainability extends to community engagement and social responsibility.

Product overview

- 01 Cornice mouldings
- 02 3D Wall covering
- 03 Skirting boards
- 04 Panel mouldings
- 05 Indirect lighting
- 06 Deco elements
- 07 The perfect finish
- 08 Flexible products



01 p. 64

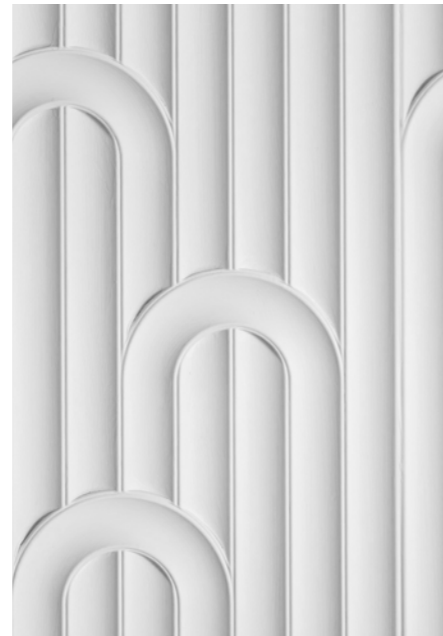

02 p. 92



03 p. 108



04 p. 122



05 p. 134



06 p. 148



07 p. 158



08 p. 162

Cornice Mouldings

ORAC

Products

01

КАРНИЗИ
GZYMSY
CORNISE
STROPNÍ LIŠTY

It truly does move us when we look up and see how it softens the strict transition between wall and ceiling. For us, a cornice is about attention to detail, be it from ornate to subtle. We have thought them all through so that there should always be an option that meets your personal aspirations.

UA –
Це зворушує нас. Коли ми дивимось вгору і бачимо, як він пом'якшує строгий перехід між стіною та стелею. Для нас карниз — це увага до деталей. Від витончатих до витончених. Ми продумали їх до дрібниць, щоб завжди був варіант, який відповідає вашим особистим вподобанням.

PL –
Naprawdę porusza nas, gdy patrzymy w górę i dostrzegamy, jak listwa sufitowa łagodzi gwałtowne przejście między ścianą a sufitem. Dla nas gzyms to dbałość o szczegóły, od ozdobnych po subtelne. Skrupulatnie przeanalizowaliśmy każdy projekt, aby zawsze istniała opcja zgodna z osobistymi preferencjami.

RO –
Ne impresionează. Atunci când ne ridicăm privirea și vedem cum tranziția bruscă de la perete la plafon este echilibrată, atenuată. Pentru noi, cornișele sunt expresia atenției la detalii. De la bogat ornamentat la subtil. Le-am conceput cu o atenție deosebită. Pentru ca dvs. să aveți întotdeauna la îndemână o opțiune care să ilustreze propriile dvs. aspirații.

CZ –
Opravdu nás dojíká. Když se podíváme nahoru a vidíme, jak zmírňuje přísný přechod mezi stěnou a stropem. Stropní lišta je pro nás o zaměření na detail. Od zdobných až po decentní. Všechny jsme je promýšleli. Tak, aby vždy existovala možnost, která splňuje vaše osobní představy.

C341 | C341F HERITAGE
Purotouch®
200 x 8,8 x 12,2 cm

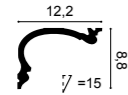

C342 HERITAGE
Purotouch®
200 x 14 x 19 cm

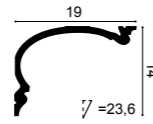

C343 HERITAGE
Purotouch®
200 x 19 x 25 cm

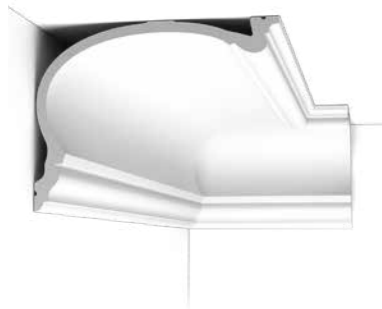
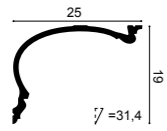

C344 HERITAGE
Purotouch®
200 x 27,3 x 35 cm

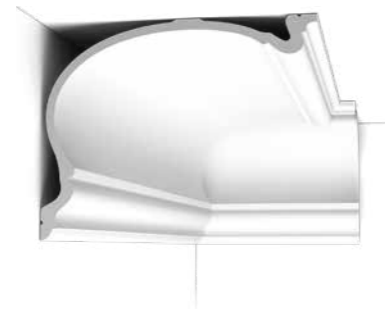
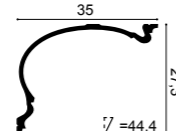

¹ C343 ² P8020 p.124



Cornice moldings

¹ C327 ² P8030 p.124 ³ P8020 p.124 ⁴ SX191 p.115

C325 MANOIR
Purotouch®
200 x 7 x 6,5 cm

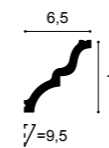

C326 MANOIR
Purotouch®
200 x 10,5 x 9 cm

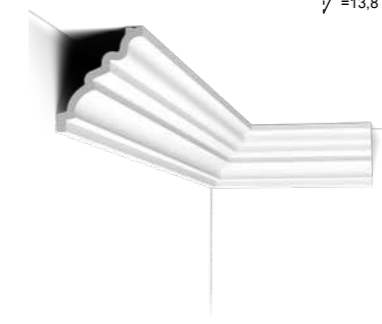
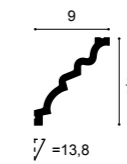

C327 MANOIR
Purotouch®
200 x 14,3 x 15,9 cm

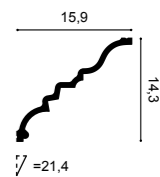

C338 BA'ROCK
Purotouch®
200 x 18,2 x 18,2 cm

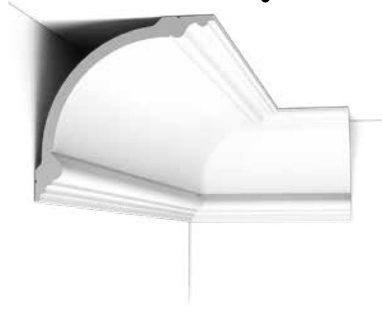
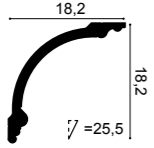

C338A BA'ROCK
Purotouch®
200 x 18,2 x 18,2 cm
Dessin: 120 cm

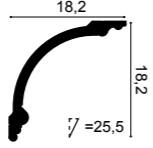

C338B BA'ROCK
Purotouch®
200 x 18,2 x 18,2 cm
Dessin: 2 x 57 cm

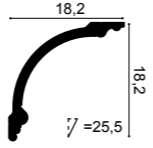

C336 BA'ROCK
Purotouch®
200 x 27,1 x 26,6 cm

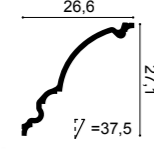

1. C217



C230 | C230F
Purotouch®
200 x 2,9 x 2,9 cm

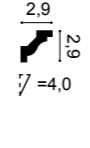

C215 | C215F
Purotouch®
200 x 4,7 x 4,7 cm

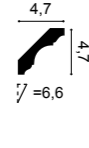

C322
Purotouch®
200 x 5 x 4,2 cm

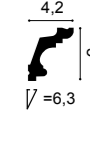

C200
Purotouch®
200 x 6,5 x 5,7 cm

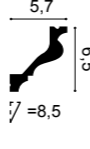

C220 | C220F
Purotouch®
200 x 7,6 x 11,6 cm

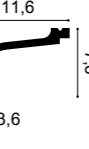

C213 | C213F
Purotouch®
200 x 8 x 8 cm

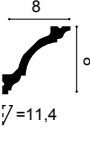

① **C217 | C217F**
Purotouch®
200 x 15,6 x 10,3 cm

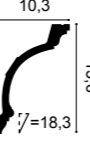

C217 | C217F ↻ 90°
Purotouch®
200 x 10,3 x 15,6 cm

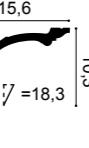

C216
Purotouch®
200 x 11,6 x 13,3 cm

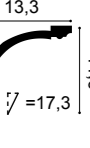

C301
Purotouch®
200 x 17 x 14,4 cm

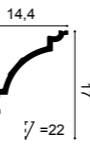

C305
Purotouch®
200 x 4,7 x 15,5 cm

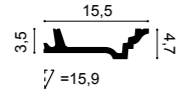

C305 + C213

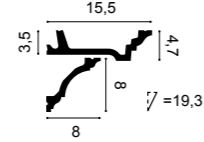

C305 + C211

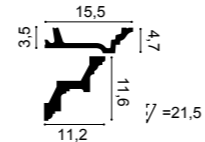

C211 | C211F
Purotouch®
200 x 11,6 x 11,2 cm

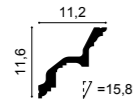

C422
Purotouch®
200 x 16,4 x 19,4 cm

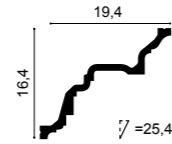

C307
Purotouch®
200 x 19,5 x 19,5 cm

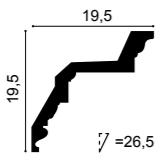

(A) C307 + C307A (B)
Purotouch®
Duropolymer®
C307A: 7,5 x 4 x 9,4 cm

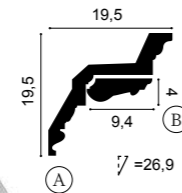

Cornice moldings

1. PX175 p.129 2. C305 3. C307A 4. C211 5. P8030 p.124 6. SX191 p.115



1. C219

C333 | C333F
Purotouch®
200 x 12,2 x 11,1 cm

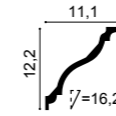

C331 | C331F
Purotouch®
200 x 6,4 x 13,5 cm

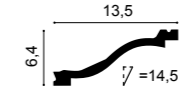

C334 | C334F
Purotouch®
200 x 15 x 19,6 cm

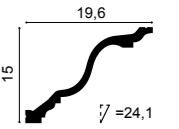

C902 | C902F
Purotouch®
200 x 10,3 x 10,3 cm

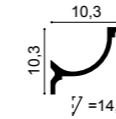

C901 | C901F
Purotouch®
200 x 14,8 x 12,4 cm

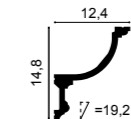

C900
Purotouch®
200 x 17,1 x 14,6 cm

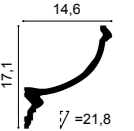

C212
Purotouch®
200 x 7,5 x 4,5 cm

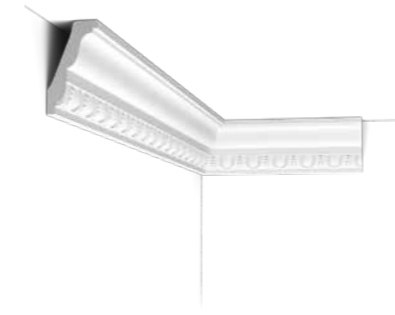
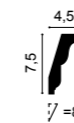

C201
Purotouch®
200 x 11,6 x 4,8 cm



C304 | C304F
Purotouch®
200 x 12,2 x 7,2 cm

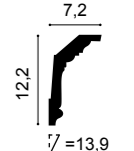

C303
Purotouch®
200 x 14,4 x 6,5 cm

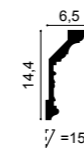

1. **C219**
Purotouch®
200 x 17,6 x 13 cm

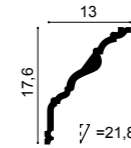

C321 | C321F
Purotouch®
200 x 9,9 x 5 cm

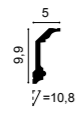

C339 | C339F
Purotouch®
200 x 14,1 x 6,4 cm

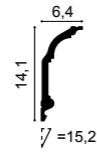

C332
Purotouch®
200 x 23 x 11,4 cm

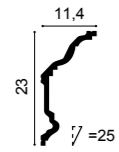

C332 90°
Purotouch®
200 x 11,4 x 23 cm

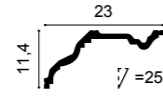

C340
Purotouch®
200 x 25,6 x 13,5 cm

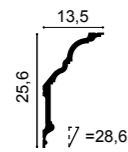

C340 90°
Purotouch®
200 x 13,5 x 25,6 cm

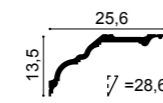

1. C332 2. P8020 p.124 3. SX118 p.111



Cornice moldings

the perfect finish



PG. 158-161

C250 | C250F
Purotouch®
200 x 1,6 x 1,6 cm

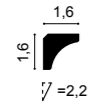

C260
Purotouch®
200 x 4,1 x 4,8 cm

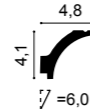

C240 | C240F
Purotouch®
200 x 8 x 8 cm

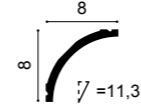

¹ C990 + 2x CX188 p.142



C991
Purotouch®
200 x 14 x 11 cm
Designed by Ulf Moritz

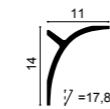

C991 + P9900

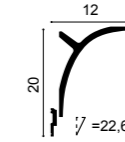

C991 + 2x P9900

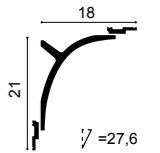

① C991 90°
Purotouch®
200 x 11 x 14 cm
Designed by Ulf Moritz

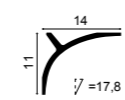

C991 + P9900 90°

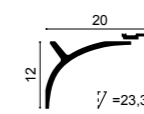

C991 + 2x P9900 90°

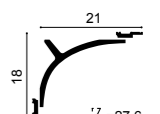

C990 INFINITY
Purotouch®
200 x 21,6 x 15,9 cm
Designed by Xavier Donck

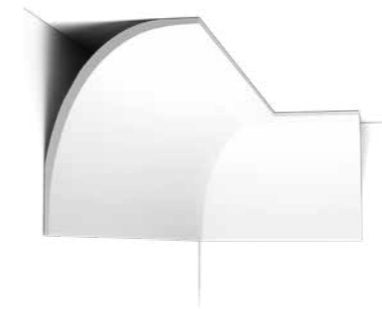
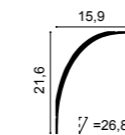

C990 + P9900

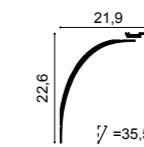

C990 + 2x P9900

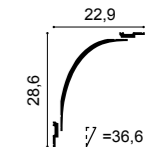

C990 INFINITY 90°
Purotouch®
200 x 15,9 x 21,6 cm
Designed by Xavier Donck

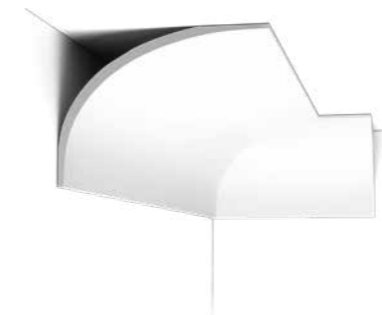
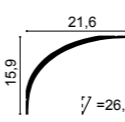

C990 + P9900 90°

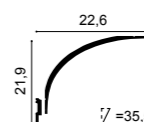

C990 + 2x P9900 90°

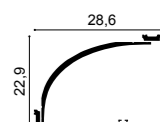

Steps

ORAC

Products

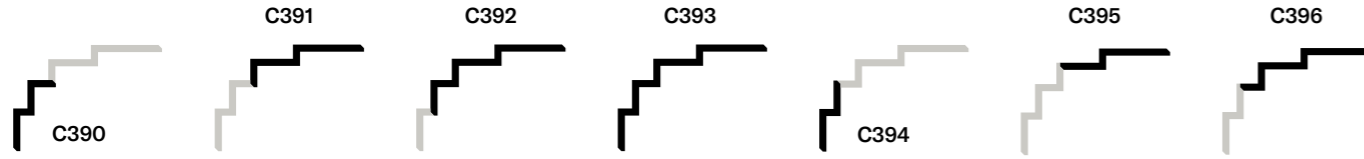

C394 STEPS
Purotouch®
200 x 9,5 x 3,1 cm
Designed by Orio Tonini

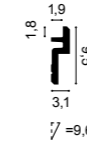

C395 STEPS
Purotouch®
200 x 15,5 x 3,1 cm
Designed by Orio Tonini



C396 STEPS
Purotouch®
200 x 18,5 x 6,1 cm
Designed by Orio Tonini

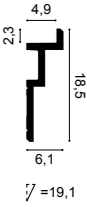

CORNICE MOULDINGS | КАРНИЗИ | GZYMSY | CORNISE | STROPNÍ LIŠTY

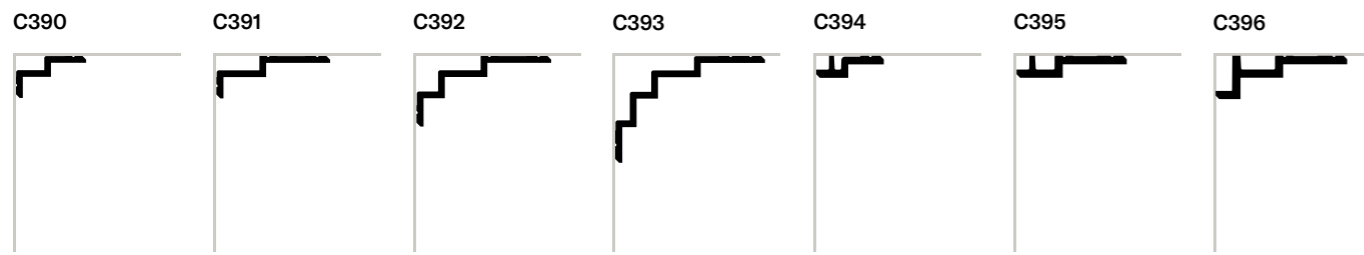

C390 STEPS
Purotouch®
200 x 6 x 10 cm
Designed by Orio Tonini



C391 STEPS
Purotouch®
200 x 6 x 16 cm
Designed by Orio Tonini

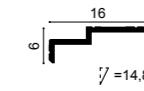

C392 STEPS
Purotouch®
200 x 10 x 19 cm
Designed by Orio Tonini

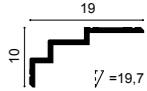

BORDER

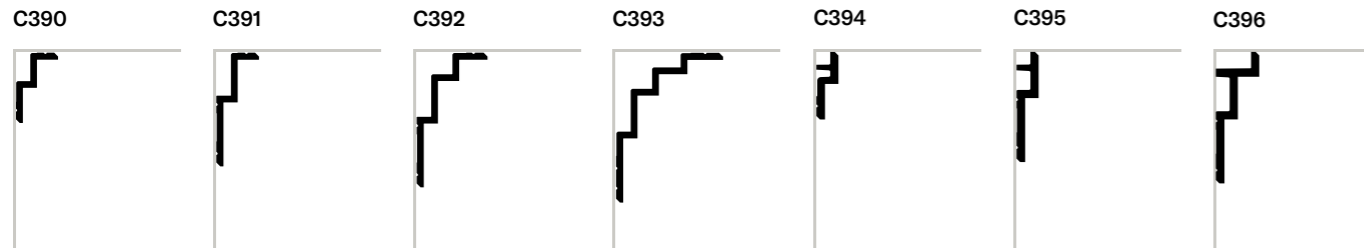

C393 STEPS
Purotouch®
200 x 15 x 21 cm
Designed by Orio Tonini

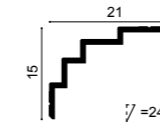

1. C391 2. C393



Cornice mouldings

CURTAIN PROFILES | КАРНИЗИ ДЛЯ ШТОП | PROFILE KARNISZOWE | CORNISI PENTRU PERDELE | GARNÝŽOVÉ PROFILY CORTINAS

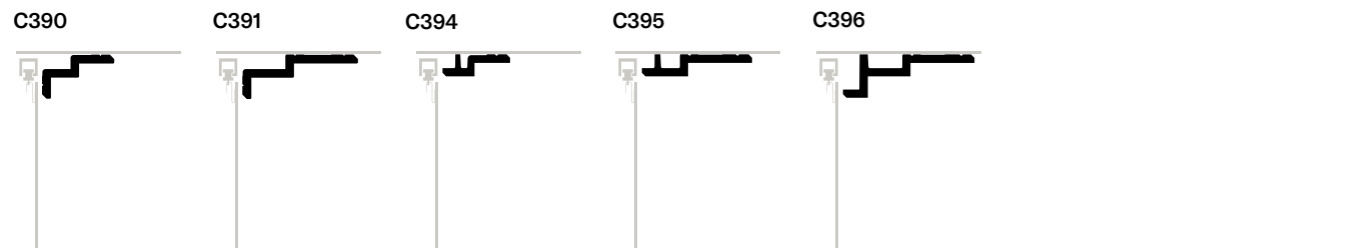

INDIRECT LIGHTING | ПРОФІЛІ ДЛЯ LED-ОСВІТЛЕННЯ | LISTWY OŚWIETLENIOWE | ILUMINAT INDIRECT | NEPŘÍMÉ OSVĚTLENÍ

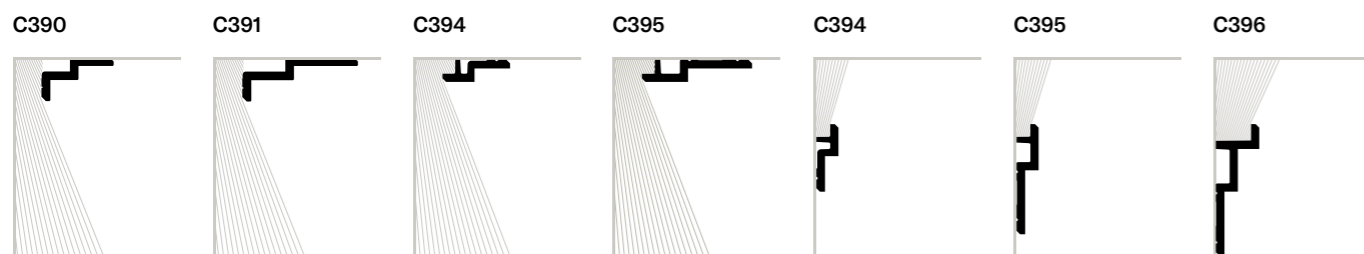

Downlighter

Uplighter

C360
Purotouch®
200 x 2,1 x 6 cm
Designed by Jacques Vergracht

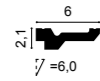

C356
Purotouch®
200 x 2 x 10 cm
Designed by Jacques Vergracht

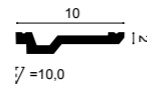

C355
Purotouch®
200 x 3,5 x 11,1 cm
Designed by Jacques Vergracht

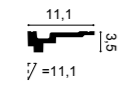

C353
Purotouch®
200 x 3 x 16,5 cm
Designed by Jacques Vergracht

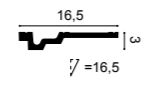

C354
Purotouch®
200 x 4 x 21,5 cm
Designed by Jacques Vergracht

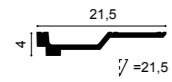

C602
Purotouch®
200 x 5,3 x 5 cm



C400
Purotouch®
200 x 6 x 10 cm

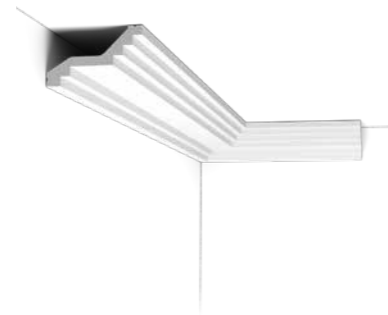

¹ C355 ² C991 p.77

Curtain profiles

КАРНИЗИ ДЛЯ ШТОП
 PROFILE KARNISZOWE
 CORNISI PENTRU PERDELE
 GARNÝŽOVÉ PROFILY



1. C340

Products

**C394 STEPS
 CURTAIN PROFILE**
 Purotouch®
 200 x 3,1 x 9,5 cm
 Designed by Orio Tonini

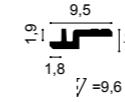

**C395 STEPS
 CURTAIN PROFILE**
 Purotouch®
 200 x 3,1 x 15,5 cm
 Designed by Orio Tonini

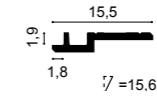

**C390 STEPS
 CURTAIN PROFILE**
 Purotouch®
 200 x 6 x 10 cm
 Designed by Orio Tonini

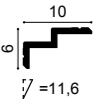

**C391 STEPS
 CURTAIN PROFILE**
 Purotouch®
 200 x 6 x 16 cm
 Designed by Orio Tonini

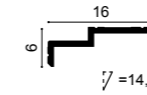

**C396 STEPS
 CURTAIN PROFILE**
 Purotouch®
 200 x 6,1 x 18,5 cm
 Designed by Orio Tonini

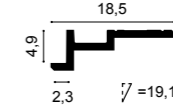

**C991
 CURTAIN PROFILE**
 Purotouch®
 200 x 11 x 14 cm
 Designed by Ulf Moritz

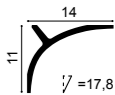

**C341 | C341F HERITAGE
 CURTAIN PROFILE**
 Purotouch®
 200 x 8,8 x 12,2 cm

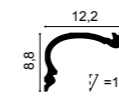

**C342 HERITAGE
 CURTAIN PROFILE**
 Purotouch®
 200 x 14 x 19 cm

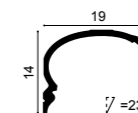

**C343 HERITAGE
 CURTAIN PROFILE**
 Purotouch®
 200 x 19 x 25 cm

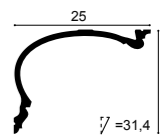

1. **C340
 CURTAIN PROFILE**
 Purotouch®
 200 x 13,5 x 25,6 cm

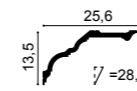

**CX196 U-STEPS
 CURTAIN PROFILE**
 Duropolymer®
 200 x 4 x 11,3 cm
 Designed by Orio Tonini



**CX197 U-STEPS
 CURTAIN PROFILE**
 Duropolymer®
 200 x 5 x 9,3 cm
 Designed by Orio Tonini



CX124 | CX124F
Duropolymer®
200 x 4,9 x 4,9 cm

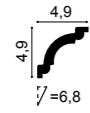

CX100 | CX100F
Duropolymer®
200 x 6,9 x 7,1 cm

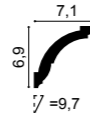

CX123 | CX123F
Duropolymer®
200 x 8 x 8 cm

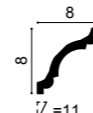

③ CX111
Duropolymer®
200 x 2,6 x 1,5 cm



CX110 | CX110F
Duropolymer®
200 x 4,5 x 4,1 cm

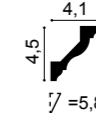

CX127 | CX127F
Duropolymer®
200 x 9,4 x 9,4 cm

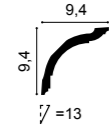

CX199 | CX199F
Duropolymer®
200 x 8 x 8 cm

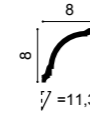

CX106 | CX106F
Duropolymer®
200 x 11,8 x 11,7 cm

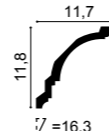

CX108
Duropolymer®
200 x 5,4 x 5,5 cm

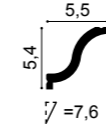

CX112
Duropolymer®
200 x 5,4 x 3,8 cm

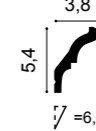

CX177
Duropolymer®
200 x 7 x 6 cm



1. P8030 p.124 2. P8020 p.124 3. CX110

CX203
Duropolymer®
200 x 14,5 x 14,5 cm

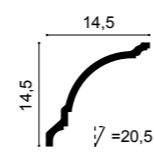

CX129
Duropolymer®
200 x 9,4 x 9,4 cm

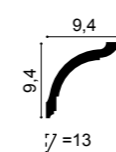

CX107
Duropolymer®
200 x 11,8 x 11,7 cm

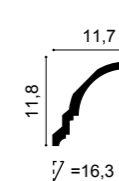

the perfect finish



CX133
Duropolymer®
200 x 2 x 2 cm



CX132
Duropolymer®
200 x 2 x 2 cm



CX115
Duropolymer®
200 x 3 x 2,9 cm



① **CX190 | CX190F U-PROFILE**
Duropolymer®
200 x 2 x 3 cm
Designed by Orio Tonini

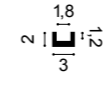

CX109 | CX109F
Duropolymer®
200 x 4,4 x 4,4 cm

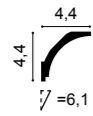

CX126
Duropolymer®
200 x 8,7 x 8,7 cm

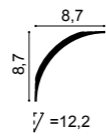

CX196 U-STEPS
Duropolymer®
200 x 11,3 x 4 cm
Designed by Orio Tonini

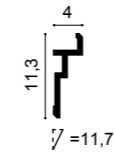

CX148
Duropolymer®
200 x 4,3 x 2,9 cm

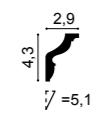

CX141
Duropolymer®
200 x 5,9 x 3,1 cm

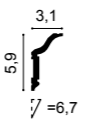

CX176
Duropolymer®
200 x 8 x 4 cm

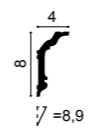

CX197 U-STEPS
Duropolymer®
200 x 9,3 x 5 cm
Designed by Orio Tonini

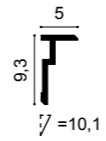

CX192
Duropolymer®
200 x 12 x 6 cm

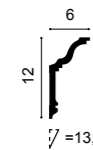

② **PX198 | PX198F U-STEPS**
Duropolymer®
200 x 8,3 x 2 cm
Designed by Orio Tonini



PX198 | PX198F U-STEPS 90°
Duropolymer®
200 x 2 x 8,3 cm
Designed by Orio Tonini



1. CX190F 2. PX198F 3. W111F p.101 4. W116F p.101 5. W119F p.101

¹ CX192 p.86 ² P8030 p.124



SX194 | SX194F SQUARE
Duopolymer®
200 x 1 x 2 cm



SX162 | SX162F SQUARE
Duopolymer®
200 x 1 x 4 cm



SX157 | SX157F SQUARE
Duopolymer®
200 x 1,3 x 6,6 cm



SX163 | SX163F SQUARE
Duopolymer®
200 x 1,3 x 10,1 cm

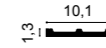

SX182 | SX182F CASCADE
Duopolymer®
200 x 1,3 x 5 cm



SX183 | SX183F CASCADE
Duopolymer®
200 x 1,3 x 7,5 cm

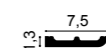

SX184 | SX184F CASCADE
Duopolymer®
200 x 1,3 x 11 cm



CX160
Duopolymer®
200 x 1,3 x 3,9 cm



CX161
Duopolymer®
200 x 1,3 x 6,9 cm

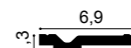

the perfect finish



CB500N
Durofoam®
200 x 2,5 x 1,8 cm

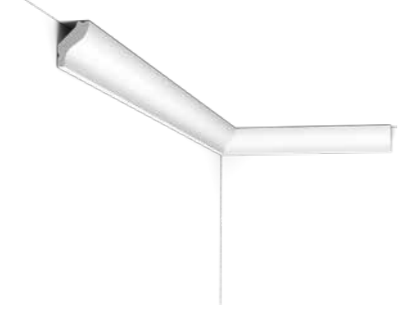
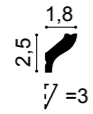

CB501N
Durofoam®
200 x 4,1 x 3,5 cm

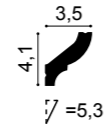

CB502N
Durofoam®
200 x 5,9 x 4,9 cm

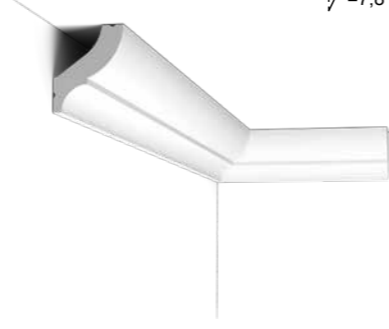
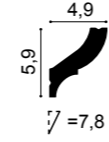

CB503N
Durofoam®
200 x 8,2 x 9,2 cm

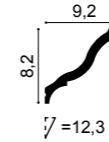

CB520N
Durofoam®
200 x 3,5 x 3,5 cm

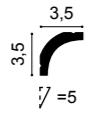

CB521N
Durofoam®
200 x 5 x 5 cm

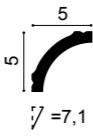

CB522N
Durofoam®
200 x 6,7 x 6,7 cm

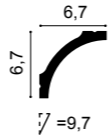

CB524N
Durofoam®
200 x 9 x 9 cm



CB525N
Durofoam®
200 x 6,5 x 6 cm

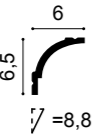

CB523N
Durofoam®
200 x 5,9 x 4,4 cm

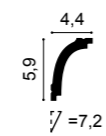

CB510N
Durofoam®
200 x 4 x 4 cm

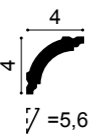

CB511N
Durofoam®
200 x 6,7 x 6,7 cm

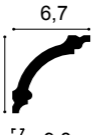

1 CB512N
Durofoam®
200 x 9 x 9 cm

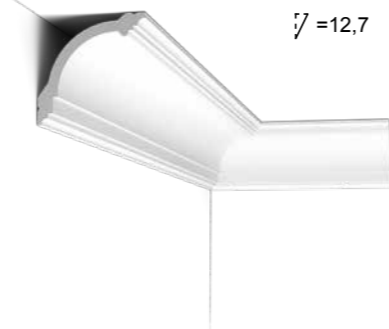
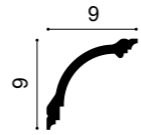

1. CB512N 2. PX103 p.129

3D Wall covering

ORAC

Products

02

СТИНОВІ 3D-ПАНЕЛІ
PANELE 3D
PANOURI DECORATIVE 3D
3D NÁSTĚNNÉ OBLOŽENÍ

We invite you to experience the extraordinary with our 3D wall coverings. Captivating sculptural landscapes, these masterpieces redefine your walls, inviting touch and exploration. Discover a range of bold and subtle designs, each a testament to the art of interior transformation.

UA—
Пориньте у дивовижний світ наших 3D-покрив для стін. Рельєфна поверхня створює унікальний і привабливий графічний ефект на стіні, до якого так і хочеться доторкнутися. Відкрийте для себе низку сміливих і витончених дизайнів, кожен з яких є підтвердженням трансформації мистецтва інтер'єру.

PL—
Jeśli chcesz, możesz doświadczyć niezwykłości dzięki naszym panelom ściennym 3D. Urzekające rzeźbiarskie krajobrazy. Te arcydzieła na nowo definiują Twoje ściany, zachęcając do dotyku i eksploracji. Poznaj gamę odważnych i subtelnych wzorów, z których każdy jest świadectwem sztuki transformacji wnętrza.

RO—
Trăiți experiențe excepționale cu panourile noastre tridimensionale pentru pereți. Peisaje sculpturale captivante. Aceste capodopere vă vor redefini pereții, invitându-vă să-i atingeți, să-i explorați. Treceți în revistă designurile îndrăznețe și subtile, fiecărui o expresie a artei transformării interioarelor.

CZ—
Pokud chcete, zažijte s našimi 3D nástěnnými obklady něco výjimečného. Podmanivé plastické scény. Tato mistrovská díla nově definují vaše stěny a vybízejí k dotekům a zkoumání. Prozkoumejte řadu odvážných i jemných vzorů, z nichž každý je dokladem umění proměny interiéru.

— Where art meets science

Duropolymer isn't new to us, but our method is. We have been making profound changes in the full lifecycle of this product. We are merging bio-based raw materials with recycled elements to create this 100% biocircular masterpiece. And we've got the ISCC certification* to prove it (for the biobased share).



UA —
Дюрополімер не є новим продуктом, але новим є спосіб його виробництва. Ми докорінно змінили весь життєвий цикл цього продукту. Поєднавши біологічну сировину з переробленими елементами, ми створили цей 100% біоциркулярний шедевр. Це підтверджує наш сертифікат ISCC* (для біосировини).

PL —
Duropolimer nie jest dla nas nowością, ale naszą metodą owszem. Dokonałiśmy głębokich zmian w całym cyklu życia tych produktów. Łączymy surowce pochodzenia biologicznego z materiałami pochodzącymi z recyklingu, aby stworzyć to w 100% biocykularne arcydzieło. Posiadamy certyfikat ISCC* jako dowód (na biopochodne produkty).

RO —
Duropolimerul nu este ceva nou pentru noi, dar metoda noastră este nouă. Am realizat în ultimii ani profunde schimbări în întregul ciclu de viață al acestui produs. Combinăm materiile prime bio cu elemente reciclate pentru a crea această capodoperă 100% biocirculară. Și avem și certificarea ISCC* pentru a dovedi acest lucru (pentru partea de biobază).

CZ —
Duropolymer pro nás není novinkou, ale naše metoda je nová. Děláme zásadní změny v celém životním cyklu tohoto produktu. Spojujeme suroviny na bázi biomateriálů s recyklovanými materiály k vytvoření tohoto 100% biocirkulačního mistrovského díla. A získali jsme certifikaci ISCC* jako potvrzení pro podíl biosložky.

Products

WX204 | WX204-2600 RIPPLE
Duropolymer®
200 x 25 x 1,6 cm
260 x 25 x 1,6 cm

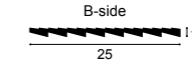
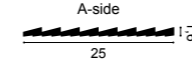

1 WX210 | WX210-2600 | WX210F REED **NEW**
Duropolymer®
200 x 25,5 x 1,2 cm
260 x 25,5 x 1,2 cm

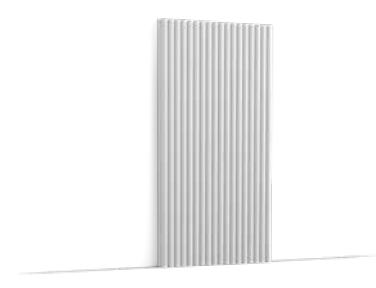
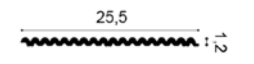

WX205 | WX205-2600 | WX205F TRACK
Duropolymer®
200 x 25 x 1,3 cm
260 x 25 x 1,3 cm

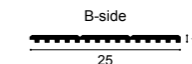
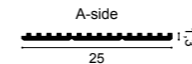

2 WX211 | WX211-2600 | WX211F FLUTE **NEW**
Duropolymer®
200 x 25,5 x 1,7 cm
260 x 25,5 x 1,7 cm

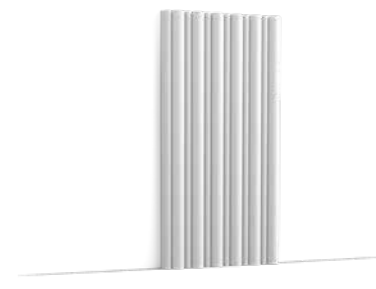
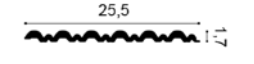

1. WX210 2. WX211

SX207 | SX207F SQUARE
Duropolymer®
200 x 25 x 1,3 cm



W108 | W108F ZIGZAG

Purotouch®
200 x 25 x 1,8 cm
Designed by Orio Tonini



W108 ZIGZAG + 2x CX190



5 W110 | W110F HILL

Purotouch®
200 x 25 x 1,6 cm
Designed by Orio Tonini

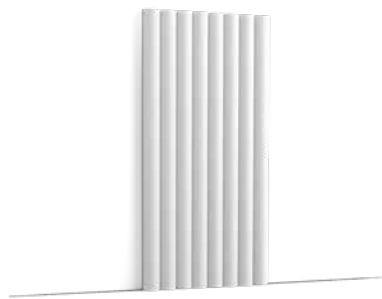
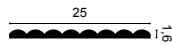

W110 HILL + 2x CX190



2 W213 HILL TRACE (NEW)

Purotouch®
200 x 25 x 1,6 cm
Designed by Orio Tonini

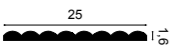

W214 | W214 HILL BEAD XL (NEW)

Purotouch®
200 x 40 x 1,5 cm
Designed by Orio Tonini



W215 HILL BEAD (NEW)

Purotouch®
50 x 80 x 1,5 cm
Designed by Orio Tonini



3D Wall coverings

1. PX209 p.131 2. W213 3. WX210 p.95 4. WX211 p.95 5. W110



1. W109 2. PX209 p.131 3. W212

6 W217 PILLOW NEW
Purotouch®
200 x 25 x 2,3 cm
Designed by Orio Tonini

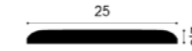

4 6 W217 PILLOW + SX182 NEW



2. PX209 p.131 4. W217 5. W218 6. SX182 p.111



3D Wall coverings

1 W109 | W109F VALLEY
Purotouch®
200 x 25 x 1,2 cm
Designed by Orio Tonini

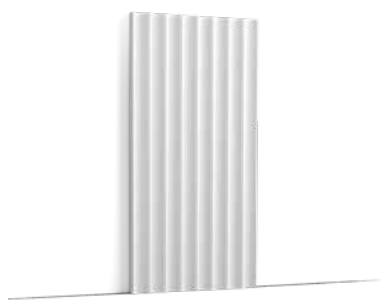
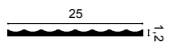

W114 | W114F VALLEY XL
Purotouch®
200 x 25 x 1,5 cm
Designed by Orio Tonini

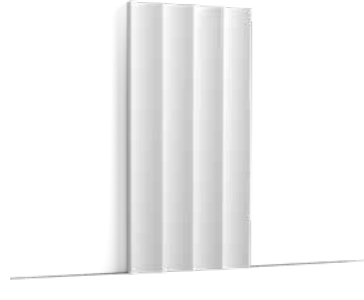
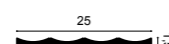

W109 VALLEY + 2x CX190



W114 VALLEY XL + 2x SX194



3 W212 VALLEY LOOP
Purotouch®
200 x 25 x 1,2 cm
Designed by Orio Tonini

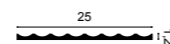

3 W212 VALLEY LOOP + 2x PX209



5 W218 QUILT NEW
Purotouch®
200 x 25 x 2,3 cm
Designed by Orio Tonini



5 6 W218 QUILT + SX182 NEW



Beyond surface beauty

ACOUSTIC CONTRIBUTION — CLASS E

In combination with other elements, Purotouch has a positive effect on the overall sound quality, absorbing up to 25% of conversational sounds.

THERMAL COMFORT

Purotouch offers thermal insulation akin to specialty insulation boards of the same thickness.

$\lambda = 0,029 \text{ W/mK}$

ECO-CONSCIOUS FROM MATERIAL TO FINISH

Over 11% of Purotouch's composition is biobased, derived from sugar beet & cane. We extend this approach up until the 14% biobased primer paint we use.

UA —

ЗВУКОІЗОЛЯЦІЯ — КЛАС Е
У поєднанні з іншими елементами, Purotouch позитивно впливає на загальну акустику приміщення, поглинаючи до 25% шуму всередині приміщення.

ТЕПЛОВИЙ КОМФОРТ
Purotouch забезпечує теплоізоляцію на рівні спеціальних ізоляційних плит тієї самої товщини.
 $\lambda = 0,029 \text{ Вт/мК}$

ЕКОЛОГІЧНІСТЬ ВІД МАТЕРІАЛУ ДО ФІНІШНОГО ПОКРИТТЯ.
У складі Purotouch >11% біологічної сировини на основі цукрового буряка й тростини. А в ґрунтовій фарбі, яку ми використовуємо, її ще більше — до 14%.

RO —

CONTRIBUTIE ACUSTICĂ - CLASA E
În combinație cu alte elemente, Purotouch are un efect pozitiv asupra calității generale a sunetului, absorbind până la 25% din sunetele conversaționale.

CONFORT TERMIC
Purotouch oferă o izolație termică asemănătoare cu cea a panourilor de specialitate, termoizolante, de aceeași grosime. $\lambda = 0,029 \text{ W/mK}$

CONȚIENT DE ASPECTELE ECOLOGICE, DE LA MATERIAL PÂNĂ LA FINISAJ
Peste 11% din compoziția Purotouch este biobază, derivată din sfeclă de zahăr și trestie de zahăr. Extindem această abordare până la vopseaua de grund cu 14% biobază pe care o folosim.

PL —

WKŁAD AKUSTYCZNY — KLASA E
W połączeniu z innymi elementami, Poliuretan posiada m.in. pozytywny wpływ na ogólną jakość dźwięku, pochłaniając do 25% dźwięków konwersacyjnych.

KOMFORT TERMICZNY
Poliuretan oferuje izolację termiczną zbliżoną do specjalistycznych płyt izolacyjnych o tej samej grubości.
 $\lambda = 0,029 \text{ W/mK}$

ŚWIADOMOŚĆ EKOLOGICZNA OD MATERIAŁU DO WYKOŃCZENIA
Ponad 11% składu Poliuretanu jest pochodzenia biologicznego z buraków cukrowych i trzciny cukrowej. Rozszerzamy to podejście do używania aż do 14% bio-farby podkładowej.

CZ —

AKUSTICKÝ PŘÍNOS - TŘÍDA E
V kombinaci s dalšími prvky má Purotouch pozitivní vliv na celkovou kvalitu zvuku, protože pohlcuje až do 25 % konverzačních zvuků.

TEPELNÝ KOMFORT
Purotouch nabízí tepelnou izolaci srovnatelnou se specializovanými izolačními deskami stejné tloušťky.
 $\lambda = 0,029 \text{ W/mK}$

EKOLOGICKY ŠETRNÝ OD MATERIÁLU AŽ PO POVRCHOVOU ÚPRAVU
Více než 11 % složení materiálu Purotouch tvoří biosložka, získaná z cukrové řepy a třtiny. Tento postup rozšiřujeme až na 14 % biosložky u primerové barvy, kterou používáme.



1. W116 2. W111 3. W119 4. CX190 p.116

3D Wall covering

② W111 | W111F BAR Purotouch® 200 x 25 x 2 cm Designed by Orio Tonini



① W116 | W116F BAR XL Purotouch® 200 x 25 x 2 cm Designed by Orio Tonini



③ W119 | W119F BAR MIX Purotouch® 200 x 25 x 2 cm Designed by Orio Tonini



② ④ W111 BAR + CX190 + PX198



① ④ W116 BAR XL + CX190 + PX198



③ ④ W119 BAR MIX + CX190 + PX198



② **W115 SLOPE**
Purotouch®
200 x 25 x 2,3

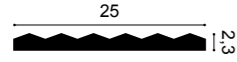

⑤ **W216 MATRIX** **NEW**
Purotouch®
200 x 25 x 1,6 cm
Designed by Orio Tonini

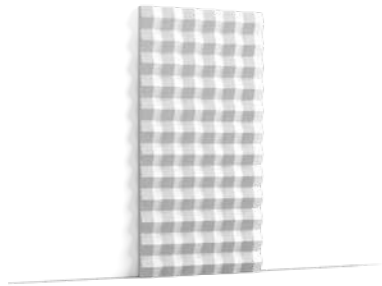
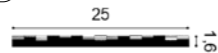

1. CX196 p.142 2. W115 3. CX190 p.116 4. PX198 p.116



5. W216

3D Wall covering

W112 RIDGE
Purotouch®
200 x 25 x 1,9 cm
Designed by Orio Tonini

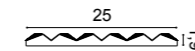

W113 COBBLE
Purotouch®
200 x 25 x 2,2 cm
Designed by Orio Tonini

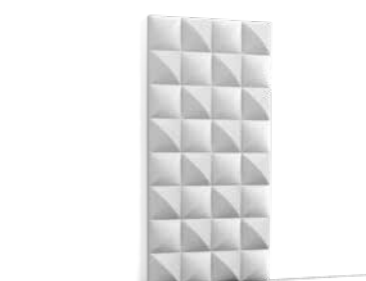
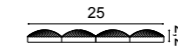

W130 CHEVRON
Purotouch®
200 x 40 x 2 cm

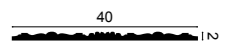

W112 RIDGE + 2x CX190



W113 COBBLE + 2x CX190



W130 CHEVRON + 2x CX190



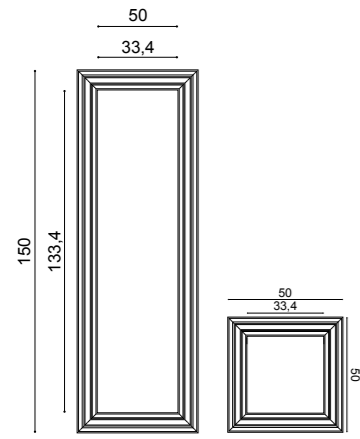

W120 + P4025 + W121
Purotouch®
Designed by Orio Tonini

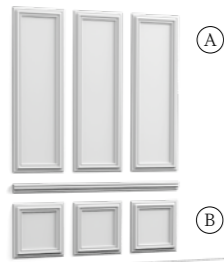

③ **W120 AUTOIRE**
Purotouch®
50 x 150 x 3,2 cm
Designed by Orio Tonini



④ **W121 AUTOIRE**
Purotouch®
50 x 50 x 3,2 cm
Designed by Orio Tonini

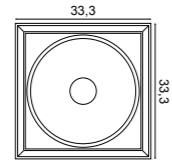

W122 AUTOIRE
Purotouch®
33,3 x 33,3 x 2,6 cm
Designed by Orio Tonini



W120 + 4*W122
Purotouch®
Designed by Orio Tonini



W121 + W122
Purotouch®
Designed by Orio Tonini

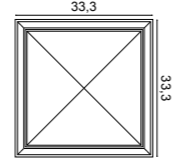
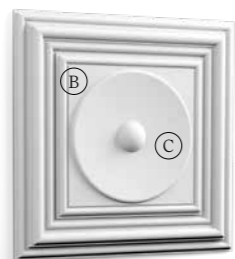

W123 AUTOIRE
Purotouch®
33,3 x 33,3 x 3,5 cm
Designed by Orio Tonini



W120 + 4*W123
Purotouch®
Designed by Orio Tonini



W121 + W123
Purotouch®
Designed by Orio Tonini

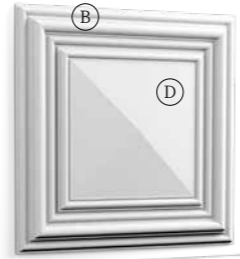

1. DX170-2300 p.154 2. D330LR p.154 3. W120 4. W121 5. SX138 p.113



3D Wall covering

W100 ROMBUS
Purotouch®
25,8 x 15 x 2,9 cm

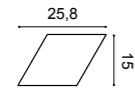

W101 TRAPEZIUM
Purotouch®
34,5 x 15 x 2,9 cm

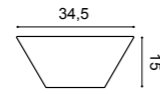

W105 ROMBUS
Purotouch®
30 x 34,6 x 3 cm

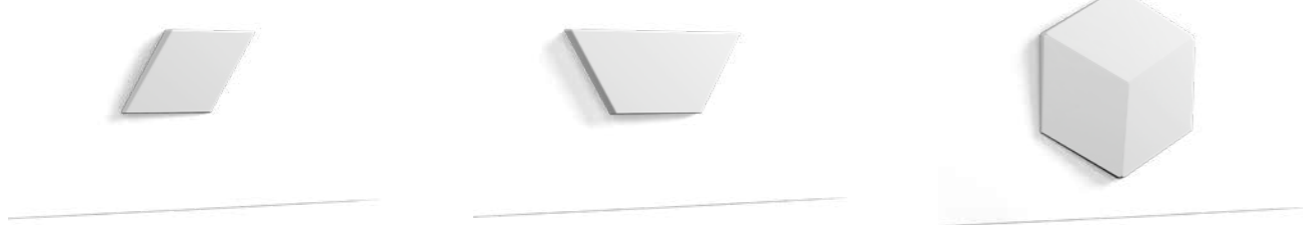
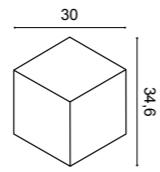

1. W106 2. W107



① **W106 ENVELOP**
Purotouch®
33,3 x 33,3 x 2,9 cm
Designed by Orio Tonini

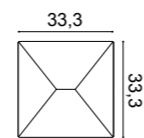

② **W107 CIRCLE**
Purotouch®
33,3 x 33,3 x 2,9 cm
Designed by Orio Tonini

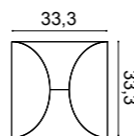

1. F30

F30
Purotouch®
59,5 x 59,5 x 4,3 cm

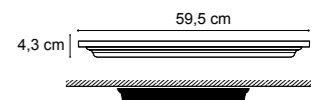

Skirting boards

ORAC

Products

ПЛІНТУСИ
LISTWY PRZYPODŁOGOWE
PLINTE
PODLAHOVÉ LIŠTY

Crafting seamless transitions from floor to wall, from the elegantly ornate to the gracefully understated. We pay meticulous attention to every detail in every design so you can find options that match your vision.

03

UA —
Ми створюємо плавні переходи від підлоги до будь-якої поверхні, від елегантно оформлених до простих, скромних елементів. У кожному проєкті ми приділяємо увагу до найдрібніших деталей, щоб ви могли знайти варіанти, які відповідають вашому баченню.

PL —
Tworzymy płynne przejścia od podłogi do ściany, od niezwykle ozdobnych po subtelne. Przywiązujemy ogromną wagę do najmniejszych szczegółów w każdym projekcie, abyś mógł znaleźć rozwiązania, które pasują do Twojej wizji.

RO —
Tranziții fluide de la pardoseală la suprafață, de la ornamente elegante la subtilitatea plină de grație. Fiecare design creat de noi este rezultatul unui proces meticolos în care atenția pentru detalii se află mereu în prim-plan, pentru ca dvs. să găsiți opțiunile care se potrivesc cu viziunea dvs.

CZ —
Vytváří plynulé přechody od podlahy k povrchu, od elegantně zdobných po půvabně nenápadné. Do každého designu vkládáme pečlivou pozornost k detailům, abyste mohli najít možnosti, které odpovídají vašim představám.

Three cornerstone skirting families

They invite you to create.

UA —
Три основні сімейства плінтусів
Вони запрошують до творчості

PL —
Trzy rodziny listew węgielnych
Zapraszają do tworzenia













RO —
Trei colecții de plinte de colț
Toate vă invită să creați

CZ —
Tři rodiny soklových lišt
Vyzývají vás k tvorbě



1. SX118 2. PX103 p.129

Products

| | small | medium | large | cover |
|--|--|---------|---------|-------|
| SX162 SX162F SX162-RAL9003 SQUARE Duropolymer® 200 x 4 x 1 cm |  1, 4 | | | |
| SX182 SX182F SX182-RAL9003 CASCADE Duropolymer® 200 x 5 x 1,3 cm |  1,3, 5 | | | |
| SX165 SX165F SX165-RAL9003 CONTOUR Duropolymer® 200 x 6,9 x 1,1 cm |  1,1, 6,9 | | | |
| SX157 SX157F SX157-RAL9003 SQUARE Duropolymer® 200 x 6,6 x 1,3 cm |  1,3, 6,6 | | | |
| SX183 SX183F SX183-RAL9003 CASCADE Duropolymer® 200 x 7,5 x 1,3 cm |  1,3, 7,5 | | | |
| SX173 SX173F SX173-RAL9003 CONTOUR Duropolymer® 200 x 10 x 1,6 cm |  1,6, 10 | | | |
| SX163 SX163F SX163-RAL9003 SQUARE Duropolymer® 200 x 10,1 x 1,3 cm |  1,3, 10,1 | | | |
| SX184 SX184F SX184-RAL9003 CASCADE Duropolymer® 200 x 11 x 1,3 cm |  1,3, 11 | | | |
| SX118 SX118F SX118-RAL9003 CONTOUR Duropolymer® 200 x 13,9 x 1,8 cm |  1,8, 13,9 | | | |
| SX171 SX171-RAL9003 SQUARE Duropolymer® 200 x 10 x 2,2 cm |  2,2, 10, 1,4 | | | |
| SX185 CASCADE Duropolymer® 200 x 12 x 2,5 cm |  2,5, 12, 9,5, 1,4 | | | |
| SX186 CONTOUR Duropolymer® 200 x 13,8 x 2,2 cm |  2,2, 13,8, 9,9, 1,4 | | | |
| | Square | Cascade | Contour | |

Skirting boards

SX195 | SX195F HAMBURG
Duropolymer®
200 x 8 x 1,9 cm



SX105 | SX105F
Duropolymer®
200 x 11 x 1,3 cm

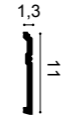

SX155 | SX155F
Duropolymer®
200 x 10,8 x 2,5 cm

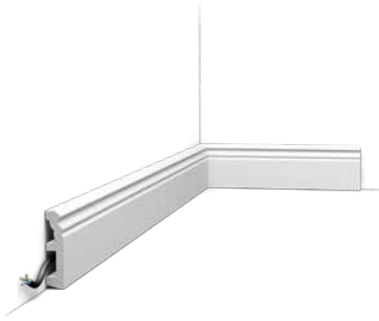

1. DX170-2300 p.154 2. P9010 p.124 3. P9050 p.126 4. SX155



1. W120 p.104 2. W121 p.104 3. W122 p.104 4. W123 p.104 5. P4025 p.124 6. SX138 p.113

SX137 | SX137F
Duropolymer®
200 x 10 x 1,5 cm



SX138 | SX138F
Duropolymer®
200 x 13,8 x 1,5 cm



SX206 CONTOUR
Duropolymer®
200 x 18 x 1,8 cm



SX193 AUTOIRE
Duropolymer®
200 x 25 x 2,2 cm
Designed by Orio Tonini

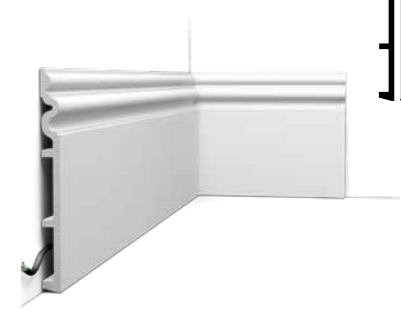

SX187 | SX187F HIGH LINE
 Duropolymer®
 200 x 7,5 x 1,2 cm
 Designed by Pierre Daems



SX180 | SX180F HIGH LINE
 Duropolymer®
 200 x 12 x 1,6 cm
 Designed by Pierre Daems

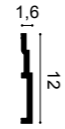

SX181 HIGH LINE
 Duropolymer®
 200 x 20 x 2,2 cm
 Designed by Pierre Daems



1- P7070 p.126 2- SX180



3- W120 p.104 4- W121 p.104 5- SX191

SX104 | SX104F
 Duropolymer®
 200 x 15 x 1,8 cm

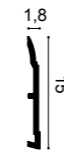

SX156 HIGH HEELS
 Duropolymer®
 200 x 20,2 x 1,6 cm
 Designed by Xavier Donck



SX191 HIGH RISE
 Duropolymer®
 200 x 21 x 2,1 cm

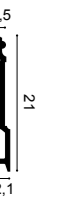

SX194 | SX194F SQUARE
Duropolymer®
200 x 2 x 1 cm

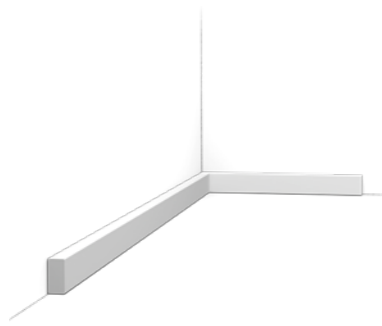

CX132 | CX132F
Duropolymer®
200 x 2 x 2 cm



CX133
Duropolymer®
200 x 2 x 2 cm



¹ C343 p.66 ² P8020 p.124 ³ CX190 ⁴ W109 p.98

³ **SX190 | CX190F U-PROFILE**
Duropolymer®
200 x 3 x 2 cm
Designed by Orio Tonini



PX198 | PX198F U-STEPS
Duropolymer®
200 x 8,3 x 2 cm
Designed by Orio Tonini



PX198 | PX198F U-STEPS 180°
Duropolymer®
200 x 8,3 x 2 cm
Designed by Orio Tonini



SX159
Duropolymer®
200 x 6 x 1,2 cm

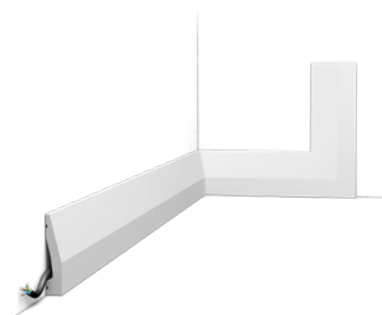

SX125
Duropolymer®
200 x 6,9 x 1,4 cm

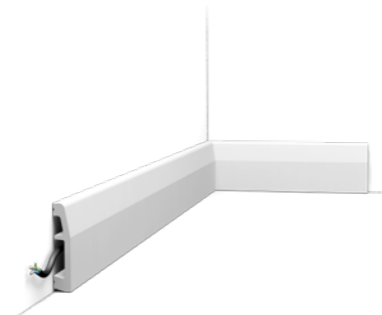

SX179 DIAGONAL
Duropolymer®
200 x 9,7 x 2,9 cm
Designed by Orio Tonini

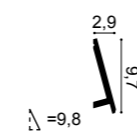

SX172 | SX172F
Duropolymer®
200 x 8,5 x 1,4 cm



SX212 CASCADE NEW
Duropolymer®
200 x 17 x 1,3 cm



Skirting boards

БАГАТОФУНКЦІОНАЛЬНІ ПРОФІЛІ
WIELOFUNKCYJNE
MULTIFUNKTIONAL
MULTIFUNKČNÍ

ORAC

Products

PX198 | PX198F U-STEPS
Duropolymer®
200 x 8,3 x 2 cm
Designed by Orio Tonini



PX198 | PX198F U-STEPS
Duropolymer®
200 x 8,3 x 2 cm
Designed by Orio Tonini



SX182 | SX182F CASCADE
Duropolymer®
200 x 5 x 1,3 cm

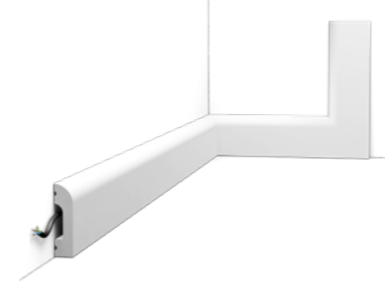

SX183 | SX183F CASCADE
Duropolymer®
200 x 7,5 x 1,3 cm



SX184 | SX184F CASCADE
Duropolymer®
200 x 11 x 1,3 cm



CX190 | CX190F U-PROFILE
Duropolymer®
200 x 3 x 2 cm
Designed by Orio Tonini

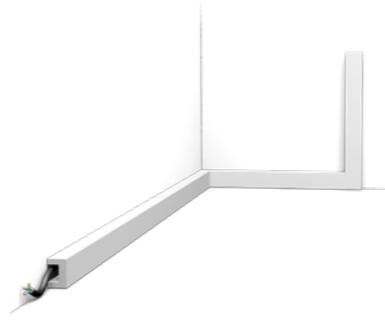

SX159
Duropolymer®
200 x 6 x 1,2 cm

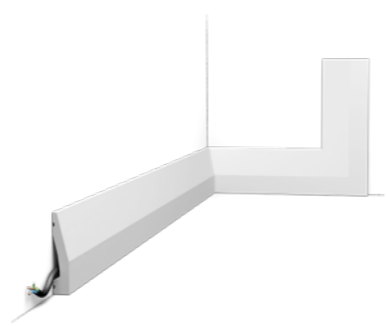

SX187 | SX187F HIGH LINE
Duropolymer®
200 x 7,5 x 1,2 cm
Designed by Pierre Daems



SX180 | SX180F HIGH LINE
Duropolymer®
200 x 12 x 1,6 cm
Designed by Pierre Daems



SX181 HIGH LINE
Duropolymer®
200 x 20 x 2,2 cm
Designed by Pierre Daems



SX194 | SX194F SQUARE
Duropolymer®
200 x 2 x 1 cm

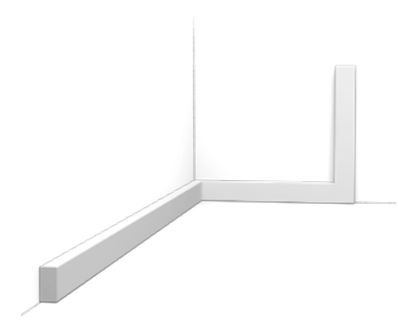

SX162 | SX162F SQUARE
Duropolymer®
200 x 4 x 1 cm

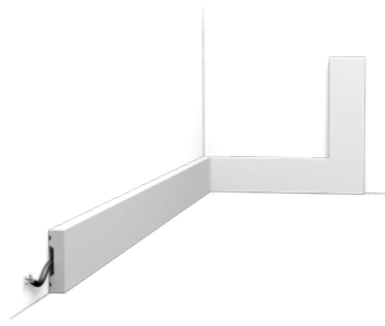

SX157 | SX157F SQUARE
Duropolymer®
200 x 6,6 x 1,3 cm

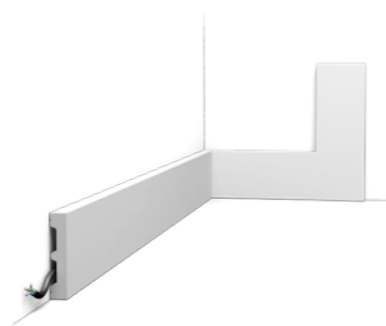

SX163 | SX163F SQUARE
Duropolymer®
200 x 10,1 x 1,3 cm



SX168 SQUARE
Duropolymer®
200 x 15 x 1,3 cm

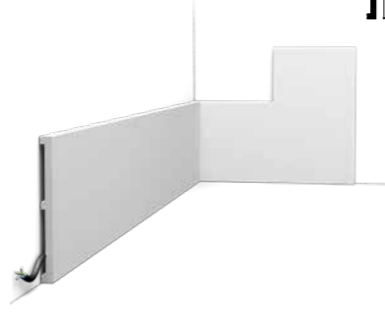

SX207 | SX207F SQUARE
Duropolymer®
200 x 25 x 1,3 cm



¹ P7070 p.126 ² SX180

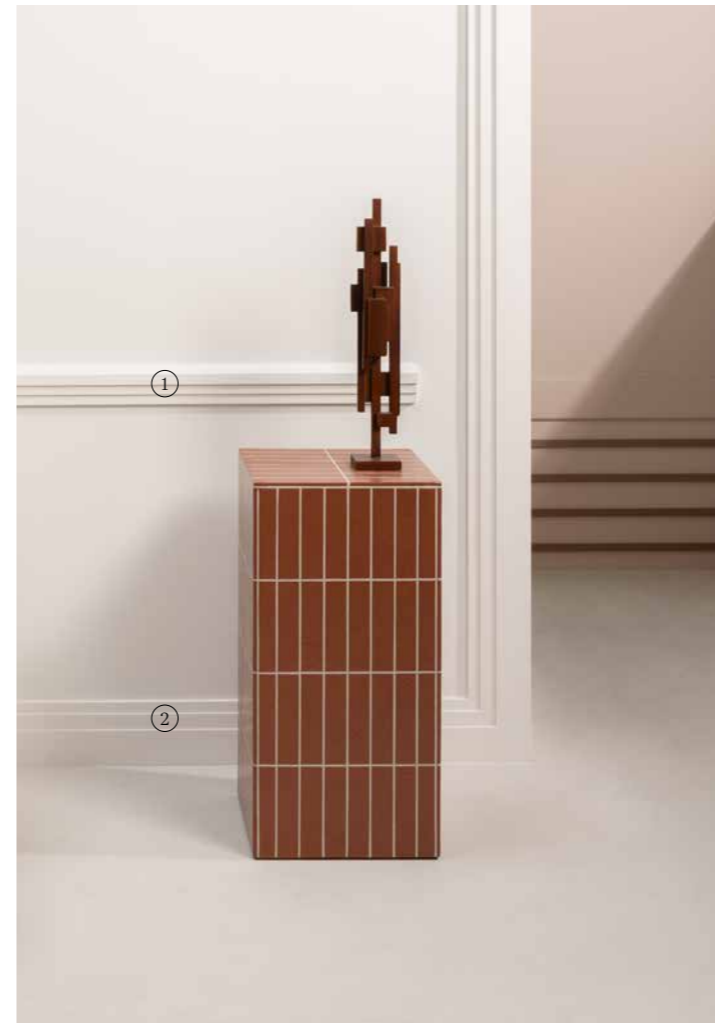

We embrace limitless possibilities. Our profiles flow seamlessly from a moulding to a door frame, fostering creativity.

UA — Ми відкриваємо безмежні можливості. Наші профілі трансформуються від молдинга до дверного обрамлення, надихаючи на творчі ідеї.

RO — Posibilitățile sunt nenumărate. Profilurile noastre transformă tot ce le înconjoară, de la o murlă la un cadru de ușă, încurajând creativitatea.

PL — Otwieramy się na nieograniczone możliwości. Nasze profile przekształcają się, od listwy po ościeżnicę, napędzając tym samym kreatywność.

CZ — Využíváme neomezené možnosti. Naše profily se přeměňují od lišty až po dveřní obložky a podporují kreativitu.

НАКЛАДНІ ПЛІНТУСИ
LISTWA PRZYKRYWAJĄCA
PLINTA DE ACOPERIRECUBRE
KRYCÍ PODLAHOVÁ LIŠTA

Cover skirting boards

Skirting boards

1. CX190 p.118



Paintable
Фарбується
Można malować
Vopsibil
Přetíratelné

Water resistant
Водостійкий
Wodoodporne
Rezistent la apă
Voděodolné

Ideal for renovations
Легке оновлення інтер'єру
Idealne do renowacji
Ideal pentru revovari
Ideální pro renovace

2. PX175 p.129 3. SX185

SX171 | SX171-RAL9003 SQUARE
Duropolymer®
200 x 10 x 2,2 cm

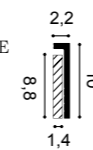

3. **SX185 CASCADE**
Duropolymer®
200 x 12 x 2,5 cm

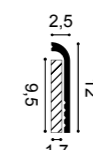

SX186 CONTOUR
Duropolymer®
200 x 13,8 x 2,2 cm

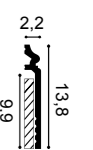

Panel mouldings

ORAC

Products

04

МОЛДИНГИ
PROFILE SCIENTE
BRAURI
LEMOVACÍ LIŠTY

An empty wall is like a bare base, in need of shape and dimension. Which is why we love to entertain ideas with these versatile accents. By using our panel mouldings, harmony comes into play, a sense of proportion that is balanced and pleasing to the eye.

UA —
Пуста стіна — це гола основа, яка потребує форми та розміру. Ось чому ми любимо грати з ідеями та різними акцентами. Завдяки використанню наших декоративних молдингів, досягається гармонія та збалансоване відчуття міри, що радує око.

PL —
Pusta ściana jest jak goła podstawa, która potrzebuje kształtu i wymiaru. Dlatego uwielbiamy bawić się pomysłami i igrać z tymi wszechstronnymi akcentami. Zastosowanie naszych listew panelowych zapewni harmonię, poczucie proporcji, które jest zrównoważone i przyjemne dla oka.

RO —
Un perete gol este ca o bază neutră, care are nevoie de formă și dimensiune. Acesta este motivul pentru care ne place să concepem ajutându-ne de aceste accente ușor adaptabile. Atunci când folosim mururile noastre tip panou, creăm armonie, proporții echilibrate și plăcute ca aspect.

CZ —
Prázdná stěna je jako holý základ, který potřebuje tvar a rozměr. Proto se rádi bavíme nápady s těmito všestrannými akcenty. Použitím našich panelových lišt vzniká harmonie, smysl pro proporce, které jsou vyvážené a příjemné na pohled.

P8030 | P8030F
Purotouch®
200 x 4,1 x 1,7 cm

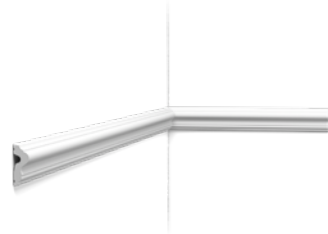

② P8020 | P8020F
Purotouch®
200 x 6 x 2,6 cm

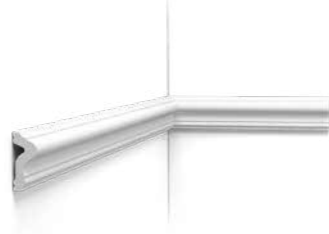

③ P8050 | P8050F
Purotouch®
200 x 12 x 3 cm

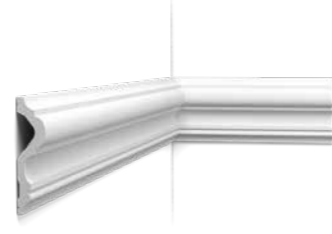

P1020
Purotouch®
200 x 4,9 x 2,4 cm

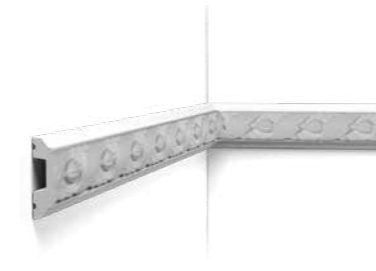

P3020 | P3020F
Purotouch®
200 x 6,1 x 3,2 cm



P4020 | P4020F
Purotouch®
200 x 5 x 2,9 cm

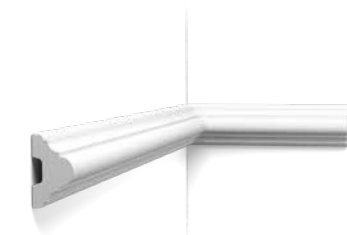

P9040
Purotouch®
200 x 5 x 2,5 cm



P9010 | P9010F
Purotouch®
200 x 9,1 x 3 cm

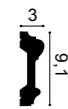

P8040 | P8040F
Purotouch®
200 x 10,1 x 2,2 cm

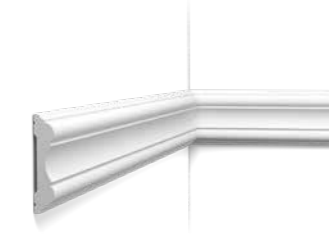

P4025 | P4025F AUTOIRE
Purotouch®
200 x 8,3 x 3,4 cm
Designed by Orio Tonini

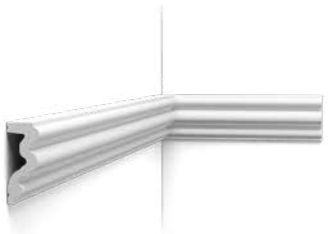

P9020
Purotouch®
200 x 9,6 x 2,1 cm

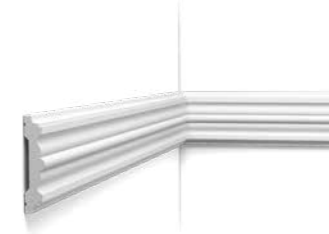

1. P8050 2. P8020 3. P8030



P6020
Purotouch®
200 x 6,4 x 2,8 cm

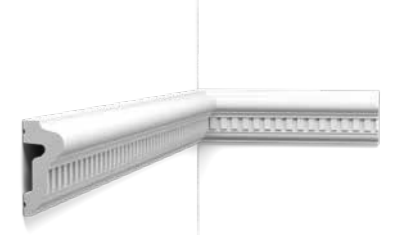

P7030
Purotouch®
200 x 8,5 x 1,7 cm

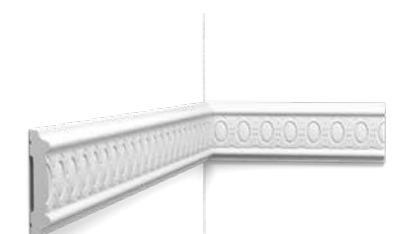
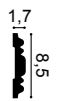

P7020
Purotouch®
200 x 11,1 x 1,9 cm

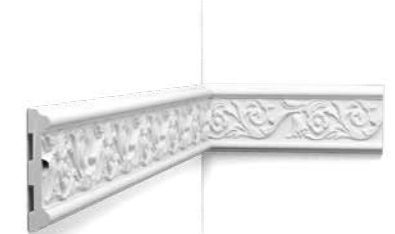

Panel mouldings

② P9050 | P9050F
Purotouch®
200 x 2,5 x 1,3 cm



P5021 | P5021F
Purotouch®
200 x 3,1 x 0,9 cm

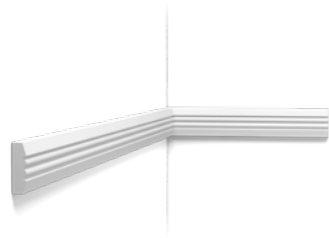

P7070 | P7070F
Purotouch®
200 x 7,4 x 2,2 cm

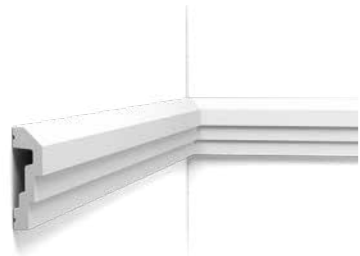

P9900 | P9900F
Purotouch®
200 x 8 x 1 cm

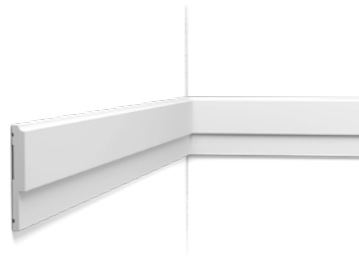
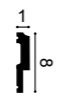

P8060
Purotouch®
200 x 5 x 3,5 cm

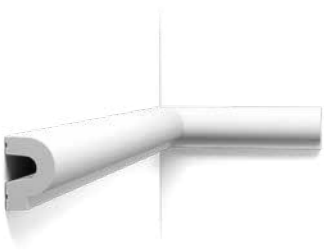

P9901
Purotouch®
200 x 7 x 1,4 cm

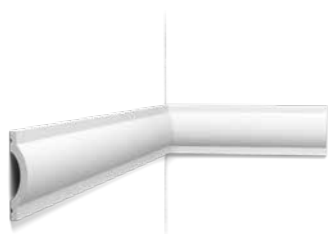

P3070 RADIUS
Purotouch®
200 x 12,5 x 3,2 cm
Designed by Ulf Moritz

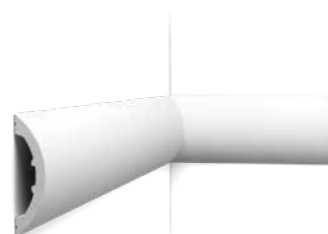
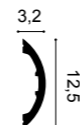

P3071 GOLF
Purotouch®
200 x 37,2 x 7,6 cm
Designed by Ulf Moritz

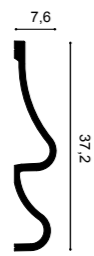

1. P9010 p.124 2. P9050 3. SX155 p.112

DX174-2300 | DX174F
 Duropolymer®
 230 x 6 x 2,2 cm (DX174-2300)
 200 x 6 x 2,2 cm (DX174F)

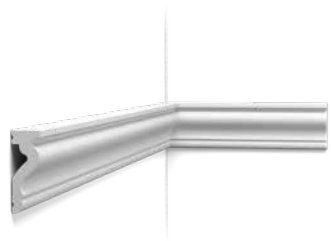

DX170-2300
 Duropolymer®
 230 x 11,9 x 3,2 cm

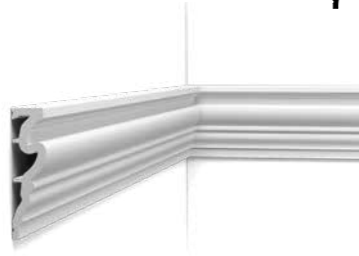

DX119-2300
 Duropolymer®
 230 x 9,2 x 2,2 cm



DX121-2300
 Duropolymer®
 230 x 9,4 x 2,3 cm

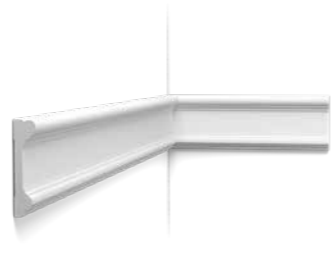
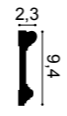

PX103 | PX103F
 Duropolymer®
 200 x 2,5 x 1,2 cm



PX120 | PX120F
 Duropolymer®
 200 x 4 x 1,9 cm

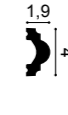

PX201 | PX201F
 Duropolymer®
 200 x 2,5 x 0,9 cm

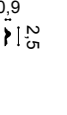

PX175 | PX175F
 Duropolymer®
 200 x 5 x 1,7 cm

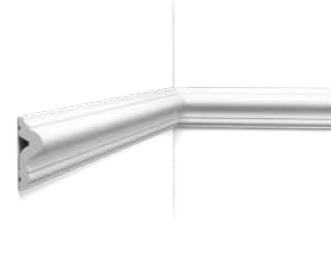

PX202 | PX202F
 Duropolymer®
 200 x 7,5 x 2 cm



PX116
 Duropolymer®
 200 x 3,1 x 1 cm

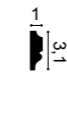

PX117
 Duropolymer®
 200 x 3,5 x 1,5 cm

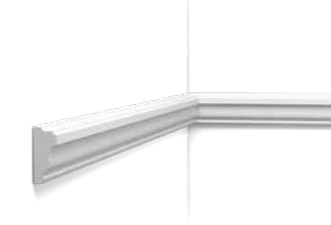

PX113
 Duropolymer®
 200 x 6 x 2,7 cm



PX144 | PX144F
 Duropolymer®
 200 x 4,7 x 0,8 cm



SX159
 Duropolymer®
 200 x 6 x 1,2 cm



¹ P8020 p.124 ² P4020 p.124 ³ SX206 p.113





1. PX209 2. SX207

SX194 | SX194F SQUARE
Duropolymer®
200 x 2 x 1 cm

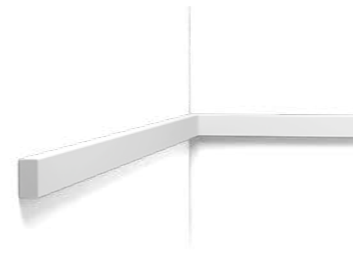

SX162 | SX162F SQUARE
Duropolymer®
200 x 4 x 1 cm

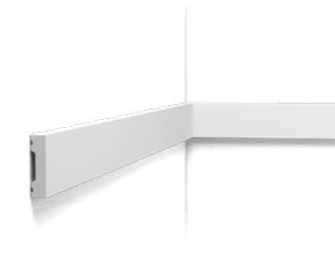

SX157 | SX157F SQUARE
Duropolymer®
200 x 6,6 x 1,3 cm

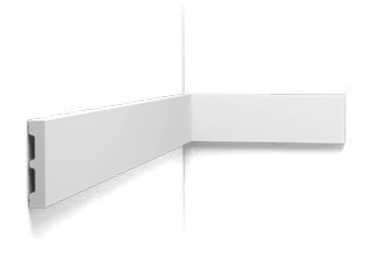

SX163 | SX163F SQUARE
Duropolymer®
200 x 10,1 x 1,3 cm

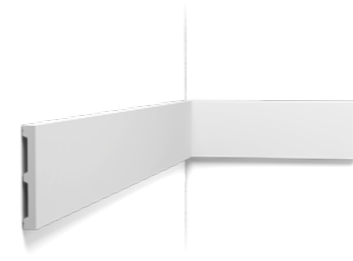

SX168 SQUARE
Duropolymer®
200 x 15 x 1,3 cm

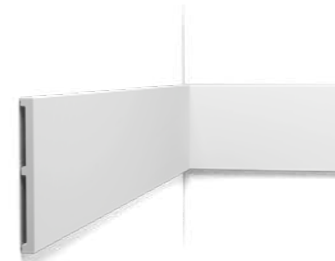

SX207 | SX207F SQUARE
Duropolymer®
200 x 25 x 1,3 cm



PX169 (A)
Duropolymer®
200 x 5,5 x 3,4 cm

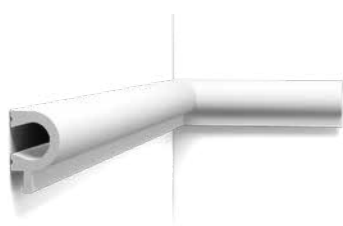

PX147 (B)
Duropolymer®
200 x 16,9 x 0,9 cm



PX169 + PX147



SX182 | SX182F CASCADE
Duropolymer®
200 x 5 x 1,3 cm



SX183 | SX183F CASCADE
Duropolymer®
200 x 7,5 x 1,3 cm

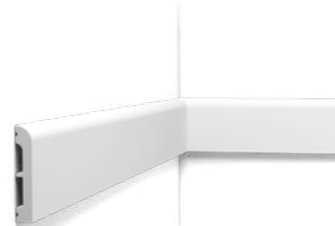

SX184 | SX184F CASCADE
Duropolymer®
200 x 11 x 1,3 cm

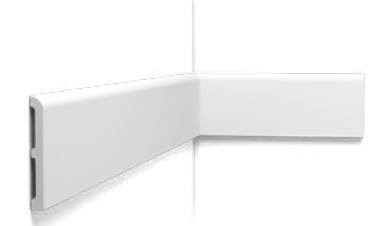

CX190 | CX190F U-PROFILE
Duropolymer®
200 x 3 x 2 cm
Designed by Orio Tonini



PX198 | PX198F U-STEPS
Duropolymer®
200 x 8,3 x 2 cm
Designed by Orio Tonini

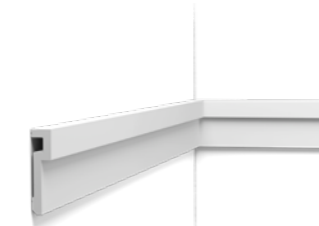

CX197 U-STEPS
Duropolymer®
200 x 9,3 x 5 cm
Designed by Orio Tonini



SX212 CASCADE (NEW)
Duropolymer®
200 x 17 x 1,3 cm



PX209 | PX209F RIBBON
Duropolymer®
200 x 1 x 1,8 cm
Designed by Orio Tonini



CX134
Duropolymer®
200 x 3 x 3 cm



1- P3020 p.125 2- P3020A 3- P8050 p.124



P101A + P1020
Purotouch®
24,5 x 24,5 x 2,4 cm

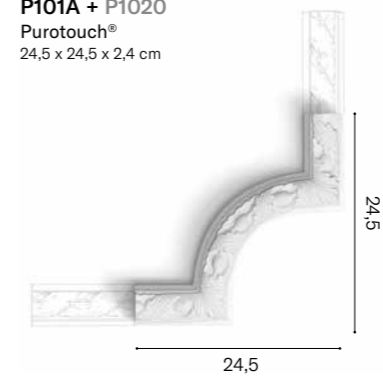

P801C + P8020
Purotouch®
19,8 x 11 x 2,6 cm



P4020A + P4020
Purotouch®
16,4 x 9,1 x 2,9 cm



P3020A + P3020
Purotouch®
42,5 x 42,5 x 4 cm

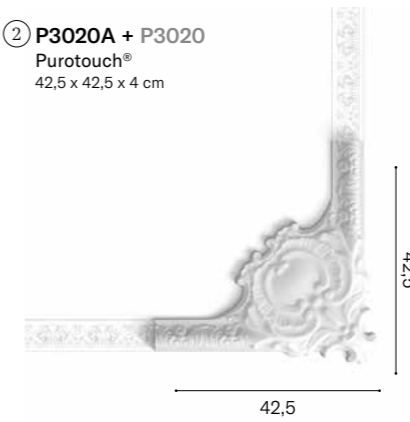

P20 + P101A
Duropolymer®
Ø 6,1 - 0,8 cm

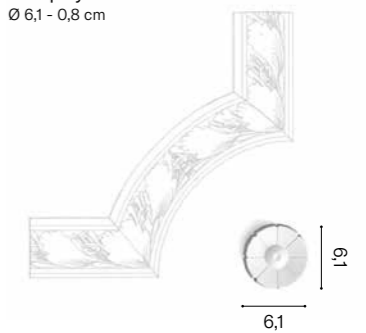

PX103A + PX103
Duropolymer®
19 x 3,5 x 1,5 cm

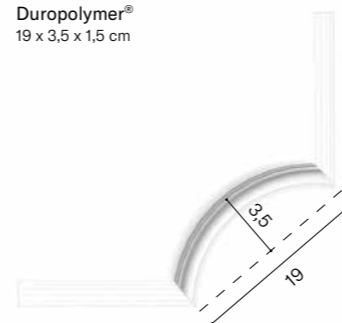

P8030D + P8030
Duropolymer®
13,2 x 13,2 x 1,7 cm

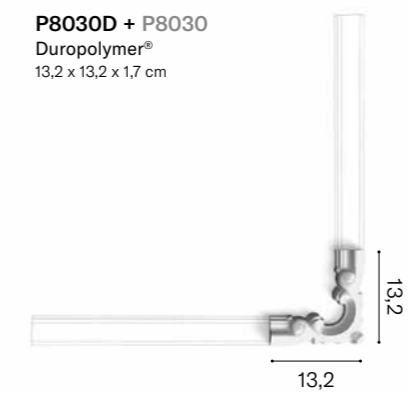

PX120A + PX120
Duropolymer®
19 x 8,8 x 2 cm

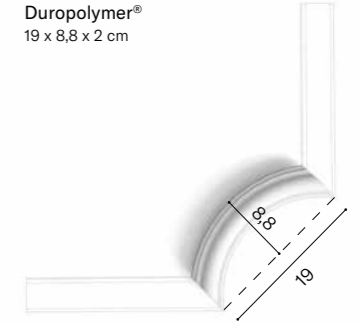

P8030C + P8030
Duropolymer®
19 x 8,6 x 1,7 cm

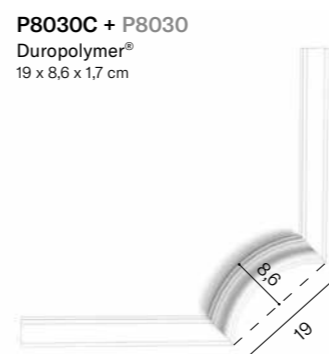

the perfect finish



PG.158-161

Indirect lighting

ORAC

Products

05

ПРОФІЛІ ДЛЯ LED-ОСВІТЛЕННЯ
LISTWY OŚWIETLENIOWE
ILUMINAT INDIRECT
NEPRÍMÉ OSVĚTLENÍ

Our indirect lighting solutions are the unseen maestros of ambiance. They are as versatile as they are subtle, designed to enhance every line and curve. So, we encourage you to integrate them as you see fit, for you to create an atmosphere that complements the time of day and the essence of the moment.

UA —
Наші рішення для прихованого освітлення — це майстри створення атмосфери. Вони настільки ж універсальні, як і витончені, створені, щоб підкреслити кожну лінію та вигин. Тож ми заохочуємо вас інтегрувати їх так, як забажаєте, щоб створити атмосферу в потрібний час та момент.

PL —
Nasze rozwiązania oświetlenia pośredniego to skryci mistrzowie tworzenia nastroju. Są równie wszechstronne, co subtelne, zaprojektowane tak, aby podkreślić każdą linię i krzywiznę. Zachęcamy więc do wykorzystania ich według własnego pomysłu, aby stworzyć atmosferę pasującą do pory dnia i charakteru danej chwili.

RO —
Soluțiile noastre de iluminat indirect creează ambianțe deosebite. Sunt adaptabile, dar și subtile, concepute să scoată în evidență fiecare linie și fiecare curbă. Vă încurajăm să le integrați în interiorul dvs. după dorință, pentru a crea o atmosferă care completează armonios momentul zilei și esența momentului.

CZ —
Naše řešení nepřímého osvětlení jsou neviditelnými mistry atmosféry. Jsou stejně všestranné jako jemné, navržené tak, aby zvýraznily každou linii a křivku. Proto vám doporučujeme, abyste je začlenili tak, jak uznáte za vhodné, abyste vytvořili atmosféru, která doplňuje denní dobu a podstatu okamžiku.

② **C323**
Purotouch®
200 x 5,5 x 4,2 cm

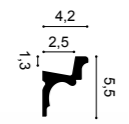

C324 AUTOIRE
Purotouch®
200 x 8,3 x 3,4 cm
Designed by Orio Torini

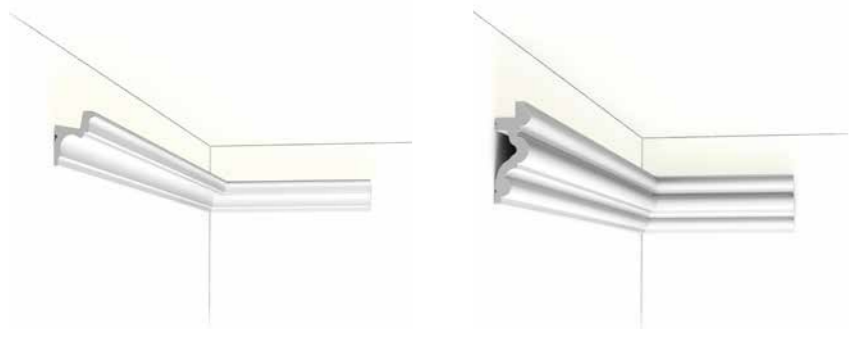
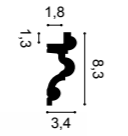

1. W212 p.98 2. C323 3. W109 p.98 4. PX209 p.131 5. SX118 p.111



C357 STRAIGHT
Purotouch®
200 x 7,1 x 11 cm
Designed by Jacques Vergracht

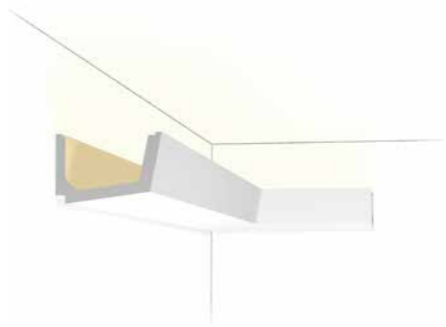
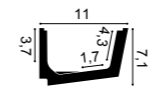

C352 FLAT
Purotouch®
200 x 7,6 x 17,1 cm
Designed by Jacques Vergracht

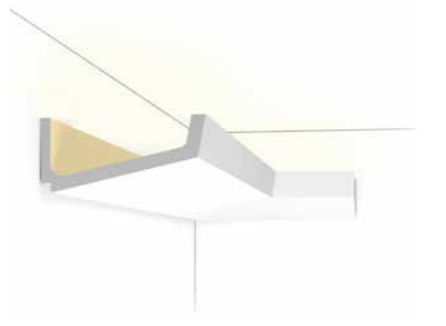
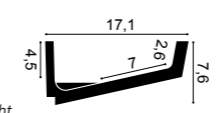

⑥ **C902 | C902F**
Purotouch®
200 x 10,3 x 10,3 cm
Designed by Jacques Vergracht

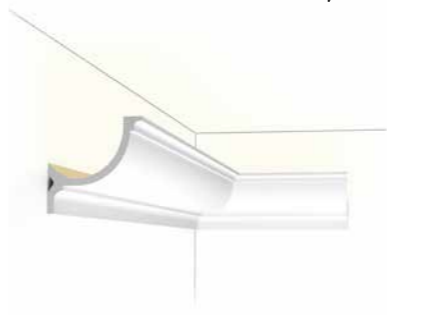
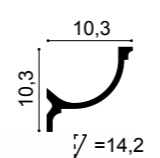

C901 | C901F
Purotouch®
200 x 14,8 x 12,4 cm
Designed by Jacques Vergracht

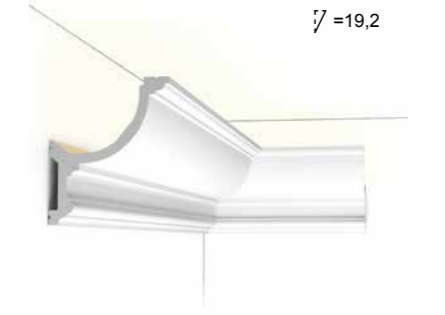
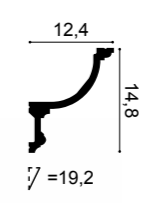

C900
Purotouch®
200 x 17,1 x 14,6 cm
Designed by Jacques Vergracht

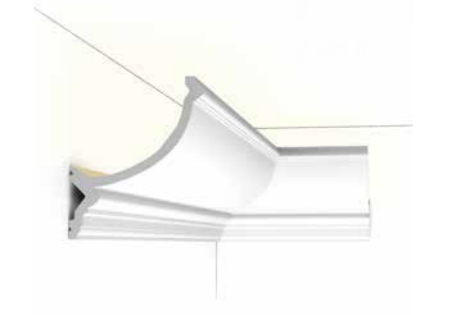
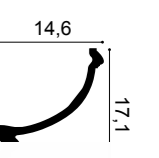

⑥ **C902**

Indirect lighting

L3 lighting combinations

ORAC

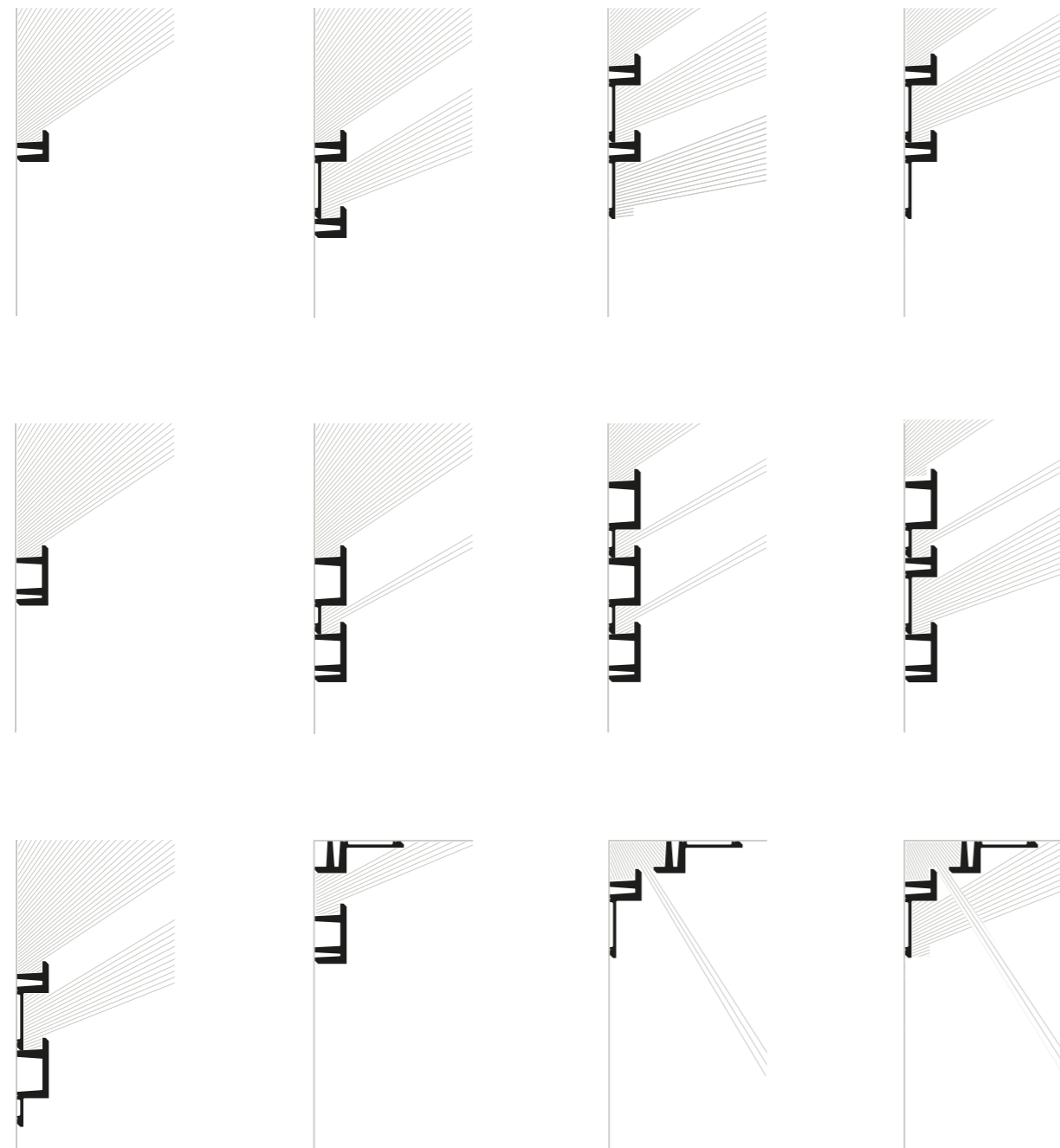

Products

③ **C380** L3 LINEAR LED LIGHTING
Purotouch®
200 x 5 x 5 cm
Designed by Orio Tonini

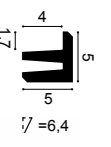

C381 L3 LINEAR LED LIGHTING
Purotouch®
200 x 9,5 x 5 cm
Designed by Orio Tonini

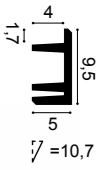

① **C382** L3 LINEAR LED LIGHTING
Purotouch®
200 x 14 x 5 cm
Designed by Orio Tonini

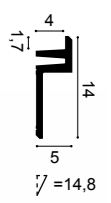

② **C383** L3 LINEAR LED LIGHTING
Purotouch®
200 x 14 x 5 cm
Designed by Orio Tonini

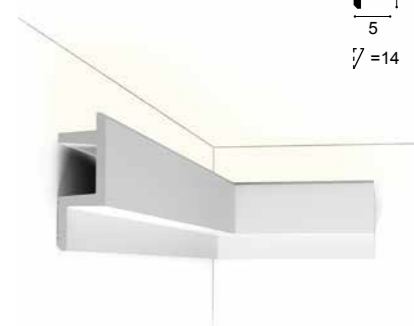
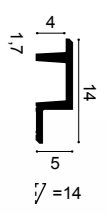

Indirect lighting

1. C382 2. C383 3. C380 4. SX180 p.114

1. C394 2. C393 p.79 3. SX180 p.114

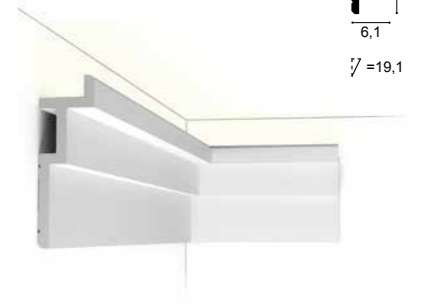
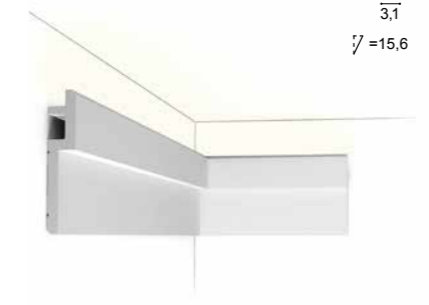
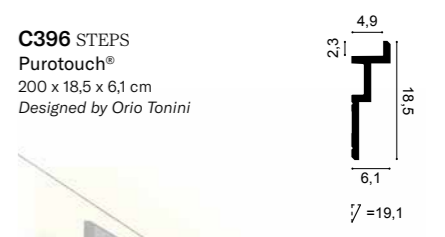
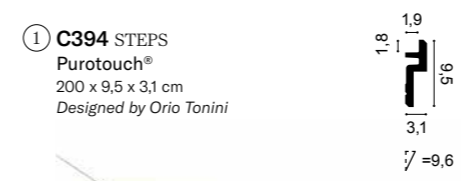
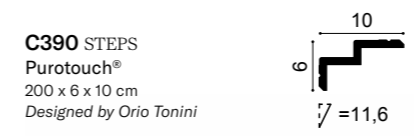
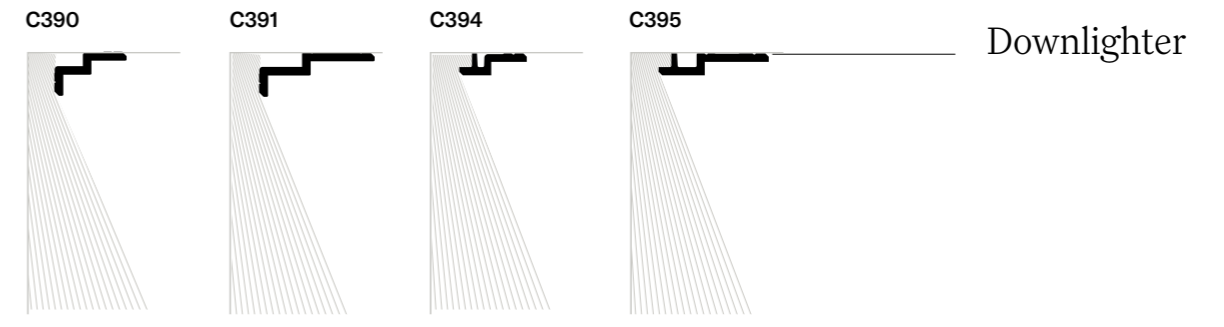
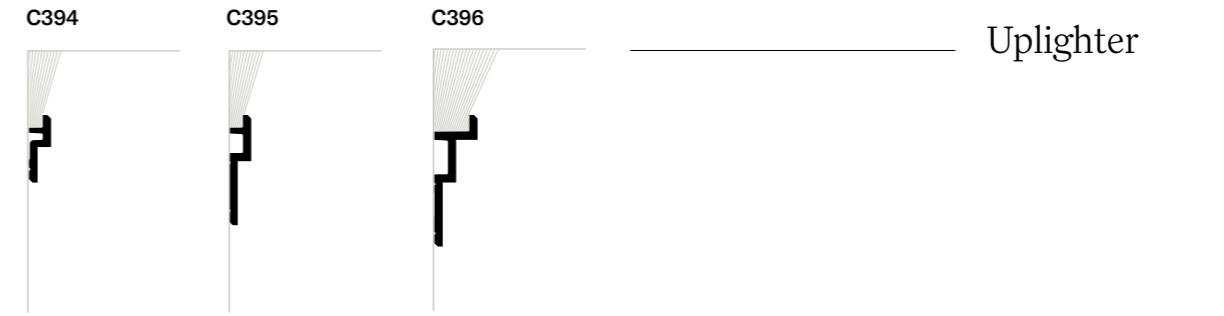

Indirect lighting

SX179 DIAGONAL
Duropolymer®
200 x 9,7 x 2,9 cm
Designed by Orio Tonini

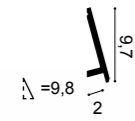

SX179 DIAGONAL
Duropolymer®
200 x 9,7 x 2,9 cm
Designed by Orio Tonini

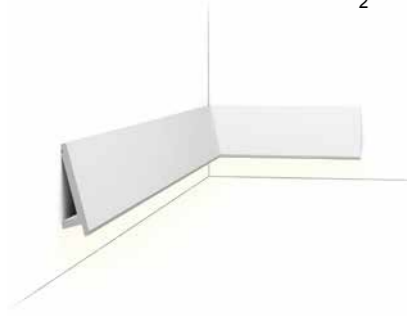

CX197 U-STEPS
Duropolymer®
200 x 5 x 9,3 cm
Designed by Orio Tonini

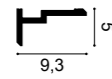

CX196 U-STEPS
Duropolymer®
200 x 11,3 x 4 cm
Designed by Orio Tonini

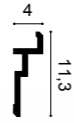

CX188 | CX188F
Duropolymer®
200 x 3,4 x 3 cm
Designed by Orio Tonini



CX189 | CX189F
Duropolymer®
200 x 2,7 x 2,7 cm
Designed by Orio Tonini



CX190 | CX190F U-PROFILE
Duropolymer®
200 x 2 x 3 cm
Designed by Orio Tonini



CX190 | CX190F U-PROFILE
Duropolymer®
200 x 2 x 3 cm
Designed by Orio Tonini



CX190 | CX190F U-PROFILE
Duropolymer®
200 x 2 x 3 cm
Designed by Orio Tonini

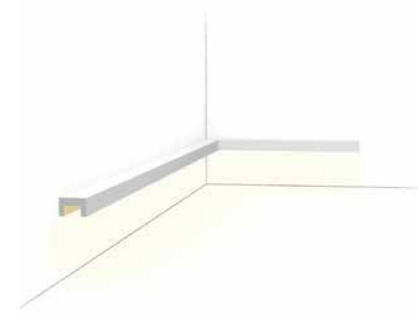

1. CX196 2. W115 p.102 3. CX190 p.118

Indirect lighting

C373 | C373F ANTONIO
Purotouch®
200 x 8 x 5 cm
Designed by Ulf Moritz

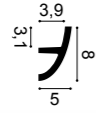

C374 ANTONIO
Purotouch®
200 x 18 x 5 cm
Designed by Ulf Moritz

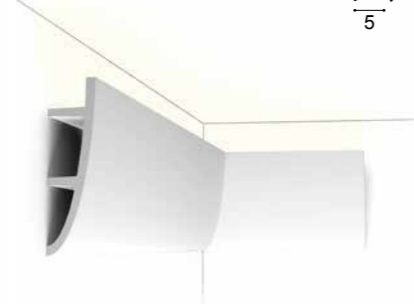
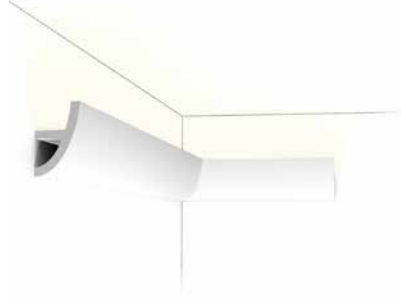
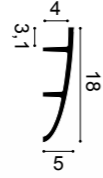

Antonio

C373 + C374



C373 + C373

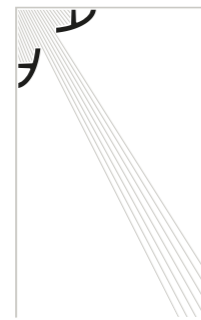

C374 + C991

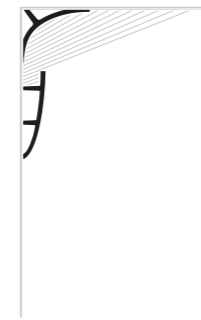

C373 + C373

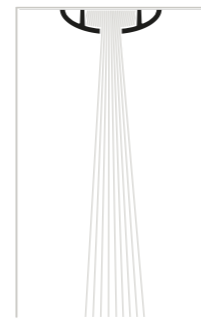

C374 + C374

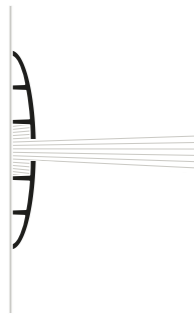

C373 + C374

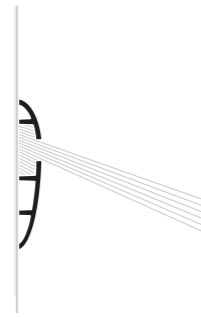

C373 + C373

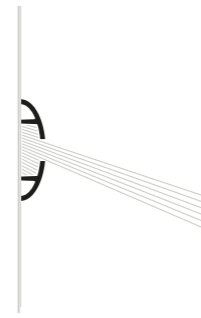

C374 + C373



C373 + C374

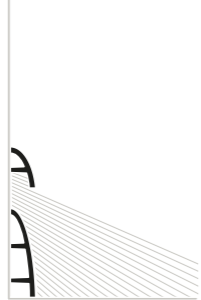

C374 + C374

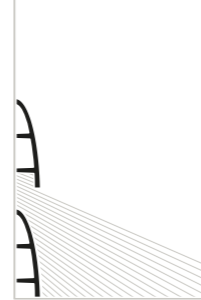

1. PX120 p.103 2. C394 p.77 3. C991 p.78 4. C361 p.129



Indirect lighting

C361 STRIPE
Purotouch®
200 x 5 x 5 cm
Designed by Pierre Daems

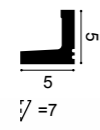

C362 CURVE
Purotouch®
200 x 5 x 5 cm
Designed by Pierre Daems

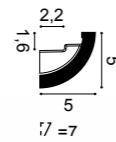

C991
Purotouch®
200 x 11 x 14 cm
Designed by Ulf Moritz

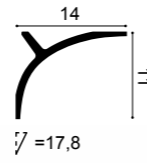

C371 SHADE
Purotouch®
200 x 18,5 x 5,8 cm
Designed by Ulf Moritz

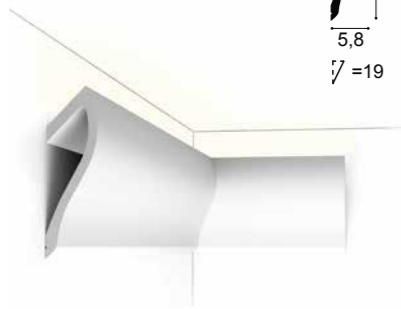
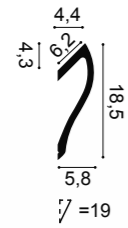

C991

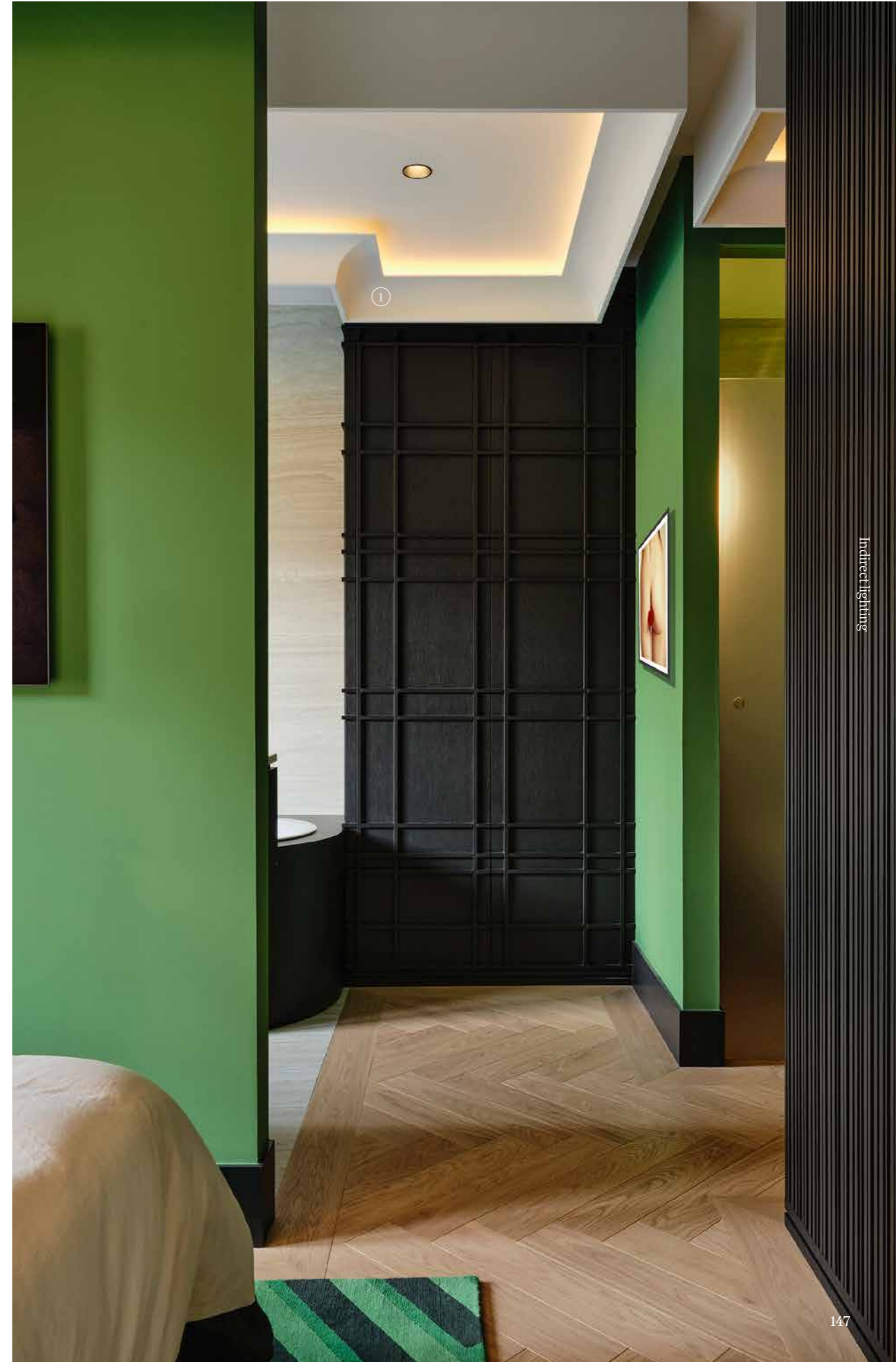

the perfect finish

PG. 158 -161



Deco elements

06

ORAC

Products

ДЕКОРАТИВНІ ЕЛЕМЕНТИ
ELEMENTY DEKORACYJNE
ELEMENTE DECORATIVE
DEKORATIVNÍ PRVKY

Deco elements are the subtle whispers of personality that breathe life into a space. From grandiose flourishes to understated accents, we propose options to punctuate your interior design narrative with finesse, for you to find what feels right.

UA —
Елементи декору — це тонкий шепіт індивідуальності, який вдихає життя в простір. Від грандіозних елементів декору до стриманих акцентів. Ми пропонуємо безліч варіантів, які вигідно підкреслять ваш дизайн інтер'єру.

PL —
Elementy dekoracyjne to subtelne szepty osobowości, które tchną życie w każdą przestrzeń. Od okazałych dodatków po stonowane akcenty — proponujemy opcje, które z finezją podkreślą narrację wystroju wnętrza, aby każdy mógł znaleźć to, co mu odpowiada.

RO —
Elementele decorative sunt indicii subtile ale personalității, care aduc la viață orice spațiu. De la detalii grandioase la accente subtile, vă propunem opțiuni care vor scoate în evidență, cu rafinement, povestea pe care o spune interiorul dvs., pentru ca dvs. să găsiți ceea ce vi se potrivește.

CZ —
Dekoratívni prvky jsou jemným vyjádřením osobnosti, které vdechují prostoru život. Nabízíme možnosti, jak jemně obohatit příběh vašeho interiéru, od velkolepých ozdob až po nenápadné akcenty, abyste našli to, co vám bude sedět nejlépe.

Ceiling roses

СТЕЛЬОВІ РОЗЕТКИ
ROZETY
ROZETE
ROZETY

ORAC



¹ R64

R10 
Purotouch®
ø 15 x 4,2 - ø 2 cm



R11
Purotouch®
ø 19 x 3,6 - ø 3 cm



R12
Purotouch®
ø 19,5 x 1,8 - ø 1 cm



Products

R13 
Purotouch®
ø 28 x 3,1 - ø 2,5 cm



R14 
Purotouch®
ø 33 x 3 - ø 2,5 cm



R31 
Purotouch®
ø 38,5 x 2,7 - ø 3,5 cm



R17 
Purotouch®
ø 47 x 3,5 - ø 6,5 cm



R18
Purotouch®
ø 49 x 4,7 - ø 7 cm



R52 
Purotouch®
ø 69,5 x 4,8 - ø 12,5 cm



R73 
Purotouch®
ø 70 x 5,9 - ø 8 cm



R23
Purotouch®
ø 71 x 4,4 - ø 6 cm



R27
Purotouch®
ø 75 x 4,5 - ø 9 cm



R22
Purotouch®
77,5 x 53 x 3,6 cm



R24
Purotouch®
ø 79 x 6 - ø 8 cm



¹ **R64** 
Purotouch®
ø 95,2 x 4,8 - ø 7 cm



R07
Purotouch®

ø 26 x 3 - ø 5 cm



R08
Purotouch®

ø 38 x 4,2 - ø 5 cm



R09 ⊕
Purotouch®

ø 48,5 x 3,7 - ø 6 cm



R76
Purotouch®

ø 62 x 4,1 - ø 10,5 cm



① **R77**
Purotouch®

ø 62 x 4,2 - ø 10,5 cm



R40 ⊕
Purotouch®

ø 74,5 x 3,1 - ø 10 cm

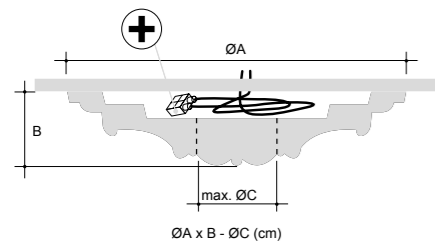

⊕ Room for cables

ВИЇМКА ДЛЯ ДРОТІВ
PRZESTRZEŃ NA KABELE
SPATIU PENTRU CABLURI
PROSTOR PRO KABELY



① R77

Door frames

ДВЕРНЕ ОБРАМЛЕННЯ
 OBRAMOWANIA DRZWIOWE
 ANCADRAMENTE DE USI
 DVERNÍ RÁMY



DX157-2300 |
DX157-2300 RAL 9003

230 x 6,6 x 1,3 cm
 Duropolymer®

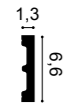

DX163-2300 |
DX163-2300 RAL 9003

230 x 10,1 x 1,3 cm
 Duropolymer®

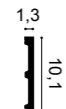

1. D170 2. D401 3. DX170-2300 4. D330LR

D210
 Duropolymer®
 9,6 x 9,6 x 3,5 cm

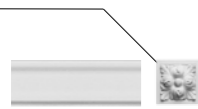

D200
 Duropolymer®
 9,6 x 9,6 x 3 cm

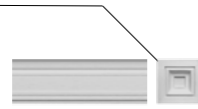

DX121-2300
 Duropolymer®
 230 x 9,4 x 2,3 cm

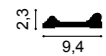

DX119-2300
 Duropolymer®
 230 x 9,2 x 2,2 cm

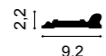

DX170-2300
 Duropolymer®
 230 x 11,9 x 3,2 cm

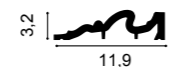

DX174-2300
 Duropolymer®
 230 x 6 x 2,2 cm

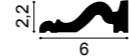

D310
 Duropolymer®
 9,5 x 24,9 x 3,1 cm

D310
 Duropolymer®
 9,5 x 24,9 x 3,1 cm

D330LR (2pc)
 Duropolymer®
 12,6 x 16 x 4,1 cm

D340
 Duropolymer®
 7 x 11 x 2,5 cm

Products

D400
 Purotouch®
 127,5 x 14,5 x 5,5 cm



D401
 Purotouch®
 127,5 x 14,5 x 5,5 cm



D402
 Purotouch®
 only for D400 and D401
 14,5 x 12 x 5,5 cm



D170
 Purotouch®
 105 x 24,5 x 3,2 cm



ΦΡΟΝΤΟΝΙ
 FRONTONY
 FRONTOANE
 ŘÍMSY

Pediments

Deco elements

ДВЕРНІ ПАНЕЛІ
 PANELE DRZWIOWE
 PANOURI PENTRU USI
 OBLOŽENÍ DVEŘÍ

Door panelling

D507
 Duropolymer®
 55 x 90,5 x 1,7 cm



D503
 Duropolymer®
 55 x 55 x 1,7 cm



D504
 Duropolymer®
 55 x 22 x 1,7 cm

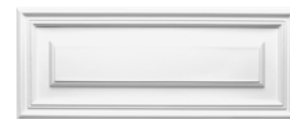

Full columns

КОЛОНИ
PEŁNE KOLUMNY
COLOANE INTREGI
PLNÉ SLOUPY

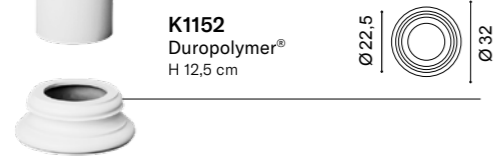
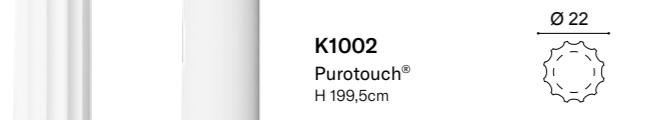

K1112 + K1002 + K1152 = 242 cm H
K1112 + K1002 + K1132 = 287 cm H max
K1122 + K1102 + K1152 = 242 cm H
K1122 + K1102 + K1132 = 287 cm H max

Half columns

НАПІВКОЛОНИ
PÓŁKOLUMNY
COLOANE JUMATATI
POLOVIČNÍ SLOUPY

ORAC

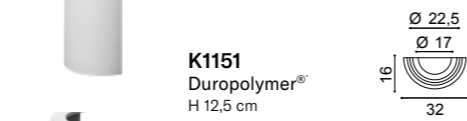
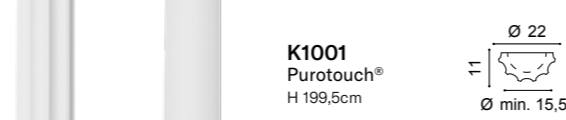
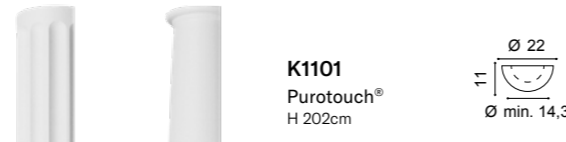

K1111 + K1001 + K1151 = 242 cm H
K1111 + K1001 + K1131 = 287 cm H max
K1121 + K1101 + K1151 = 242 cm H
K1121 + K1101 + K1131 = 287 cm H max

Products

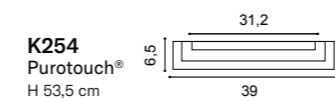
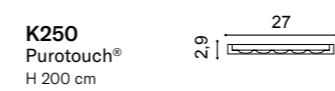

1. K1122
2. K1002
3. K1152
4. K251
5. K250
6. K254



Pilasters

ПІЛЯСТРИ
PILASTRY
PILASTRI
PILASTRY

Deco elements

The perfect finish

07



БЕЗДОГАННИЙ РЕЗУЛЬТАТ
IDEALNE WYKONCZENIE
FINISARE PERFECTA
PERFEKTNÍ ZAKONČENÍ

We once vowed never to stop at what looks good. That's why our products stand the test of time, right down to the glue that holds them in place. Our installation products are the silent artisans behind the scenes, ensuring a seamless and straightforward installation of our architectural elements.

UA —

Колись ми запрягнулися ніколи не зупинитися на тому, що гарно виглядає. Саме тому наша продукція витримує випробування часом, починаючи з клею, який тримає її. Наші монтажні вироби - це мовчазні ремісники, які забезпечують безшовну і просту інсталяцію наших архітектурних елементів.

PL —

Kiedyś przysięgliśmy nigdy nie zadowalać się wyłącznie efektami estetycznymi. Dlatego nasze produkty wytrzymują próbę czasu, włącznie z klejem, który je mocuje. Nasze produkty instalacyjne działają jak cisi rzemieślnicy za kulisami, zapewniając płynną i prostą instalację naszych elementów dekoracyjnych.

RO —

Ne-am propus, în trecut, să nu ne oprim doar la aspectul plăcut. Acesta este motivul pentru care nu doar produsele noastre, ci și adeziv cu care sunt fixate, rezistă în timp. Produsele noastre pentru instalare sunt artiștii neștiuți din spatele scenei, care asigură instalarea simplă, fără complicații, a elementelor noastre arhitecturale.

CZ —

Kdyysi jsme si slíbili, že se nikdy nezastavíme jen u toho, co vypadá dobře. Proto naše produkty odolávají zkoušce časem, a to až po lepidlo, které je drží na místě. Naše instalační produkty jsou tichými pomocníky v pozadí, kteří zajišťují bezproblémovou a jednoduchou instalaci našich architektonických prvků.

Surface and atmosphere

ПІДГОТОВКА ПОВЕРХНІ ТА НАВКОЛИШНЄ СЕРЕДОВИЩЕ
 POWIERZCHNIA & ATMOSFERA
 SUPRAFATA & AMBIENT
 POVRCH & PODMÍNKY

ORAC

Storage and installation conditions: Store profiles and adhesives at room temperature and wait 24 hours before installing.



Умови зберігання та монтажу: зберігати профілі та клеї при кімнатній температурі; перед монтажем зачекайте 24 години.
 Warunki przechowywania i użycia kleju: profile i kleje przechowywać w temperaturze pokojowej, odczekać 24 godziny przed instalacją.
 Conditii de depozitare si instalare: depoziteaza profilele si adezivii la temperatura camerei cu 24h inainte de instalare.
 Skladovací a instalační podmínky: skladujte profily a lepidla v pokojové teplotě a vyčkejte 24 hod než začnete instalovat.



Dust free
 Без пилу
 Bez kurzu
 Fara praf
 Bez prachu



Sand and wash surface
 Відшліфувана та чиста поверхня
 Wyszlifowana i umyta powierzchnia
 Suprafata neteda si curata
 Obrušte a očistěte povrch



Flat wall & ceilings
 Рівні стіни та стелі
 Plaska ściana i sufit
 Perete & tavan plat
 Rovná stěna & strop



Dry
 Sucha
 Sucha
 Uscat
 Suché



No grease
 Знежирена
 Bez tłuszczu
 Fara grasime
 Odmaštěné

Decofix adhesives

КЛЕЙ DECOFIX
 KLEJE DECOFIX
 ADEZIVI DECOFIX
 DECOFIX LEPIDLA



Interior, porous and dry surface
 Для внутрішніх робіт, пористих та сухих поверхень
 Wewnątrz, do powierzchni porowatych i suchych
 Suprafata la interior, poroasa si uscata
 Pro použití v interiéru, porézni a suchý povrch



Heavy profiles or
 Для важких профілів або
 Duże profile lub
 Profile mari si
 Těžký profil nebo



Exterior, non-porous and humid surfaces and 3D Wall Covering
 зовнішніх робіт, неporистих і вологих поверхень
 Na zewnątrz, do powierzchni nieporowatych i wilgotnych i panele 3D
 grele sau suprafata la exterior, non-poroasa si umeda si panouri decorative 3D
 Pro použití v exteriéru, neporézni a vlhký povrch

Products

DecoFix Pro



FDP500 310ml
 > 7 — 8m

Extra strong installation adhesive for porous surfaces and interior applications
 · Strong, water-based acrylic glue
 · Long-lasting seal between mouldings and the wall and/or ceiling
 · Remove with humid sponge or cloth
 · Should be kept frost free
 · Paintable after hardening (min. 24 hours)

Надміцний клей для внутрішніх робіт та пористих поверхень
 · Міцний акриловий клей на водній основі
 · Довговічне з'єднання між профілями та стіною і/або стелею;
 · Видаляється за допомогою вологої губки чи ганчірки
 · Зберігати в захищеному від морозу місці
 · Ліпний декор можна фарбувати після затвердіння (мін. через 24 год)

DecoFix Power



FDP700 290ml
 > 7 - 8m

Extra strong MS polymer glue for new build, all exterior applications, non-porous (tiles, glass, ...) surfaces, damp environments and 3D wall covering
 · Remove with humid sponge or cloth
 · Paintable after hardening (min. 24 hours)

Надміцний полімерний клей для новобудов, будь-яких зовнішніх робіт, неporистих поверхень (плитка, скло тощо), а також для вологих приміщень
 · Надлишки видаляються мильним розчином
 · Можна фарбувати після затвердіння (мін. через 24 год)

DecoFix Ultra



FX400 270ml
 > 80m

White, polymer-based adhesive for joints between mouldings
 · Apply sufficient DecoFix Ultra in every joint.
 · Push profiles strongly against each other and remove excess glue with a painter's knife before hardening.
 · Use FL300 DecoFiller if needed and finish with sandpaper.
 · Can be painted after 24 hrs.

Білий клей на полімерній основі для стикування профілів між собою
 · Нанести достатню кількість DecoFix Ultra на кожен стик.
 · Притиснути профілі один до одного та видалити надлишки клею малярним ножом до затвердіння.
 · За потреби нанести шпаклівку FL300 DecoFiller та відшліфувати наждачним папером.
 · Можна фарбувати через 24 години.

DecoFiller



FL300 310ml
 > 30m

Ready to use lightweight acrylic filler
 · For shrink-proof finishing of gaps (between decorative profiles after adhesion, between wall and profiles, between walls and ceiling), cracks and irregularities in profiles or on walls
 · Rapidly repaintable (after 15 min.)
 · Does not crack

Готова до використання легка акрилова шпаклівка
 · Безусадкова, для заповнення щілин (між декоративними профілями після монтажу, між стіною і профілями, між стінами та стіною і стелею), тріщинами і виправлення нерівностей на профілях або на стінах
 · Швидко сохне (готова до фарбування через 15 хв)
 · Не розтріскується

Wyjątkowo mocny klej instalacyjny do aplikacji we wnętrzach na porowatych powierzchniach
 · Mocny, akrylowy klej na bazie wody
 · Długotrwałe uszczelnienie pomiędzy listwami, a ścianami lub sufitami
 · Nadmiar usuwać za pomocą wilgotnej gąbki lub szmatki
 · Chronić przed mrozem
 · Nadaje się do malowania po całkowitym stwardnieniu (min. 24 godz.)

Wyjątkowo mocny klej MS polimerowy do konstrukcja nowa, stosowania na zewnątrz, na gładkich powierzchniach (płytki, szkło itp.) w wilgotnym środowisku i panele 3D
 · Usuwać roztworem z mydła
 · Nadaje się do malowania po całkowitym stwardnieniu (min. 24 godz.)

Klej na bazie polimerów biały łączenie między listwami.
 · Nanieść wystarczającą ilość DecoFix Ultra w każdym łączeniu
 · Mocno docisnąć listwy do siebie i po stwardnieniu kleju usunąć jego nadmiar
 · W razie potrzeby użyć FL300 DecoFiller i wykończyć papierem ściernym
 · Można malować po 24 godzinach

Gotowy do użycia lekki wypełniacz akrylowy
 · Do niekuczliwego wykańczenia szczelin (pomiędzy profilami ozdobnymi po przyklejeniu, między ścianami i profilami, pomiędzy ścianami oraz sufitami), a także pęknięć i nierówności w profilach lub na ścianach
 · Możliwość szybkiego ponownego malowania (po 15 min.)
 · Nie pęka

Adeziv pentru o instalare foarte puternică pe suprafețe poroase si aplicatii la interior
 · Puternic, silicon acrilic pe baza de apa
 · Lipire de lunga durata între profile si perete si/sau tavan
 · Se indeparteaza cu un burete umed sau o carpa.
 · A se feri de inghet
 · Vopsirea se face dupa intarire (min. 24h)

Silicon MS polimer foarte puternic pentru construcție nouă, instalarea la exterior, suprafețe non-poroase (gresie, sticlă, ...) si medii umede si panouri decorative 3D
 · Se indeparteaza cu solutie de sapun
 · Vopsirea se face dupa intarire (min. 24h)

Adeziv pe bază de polimer alb pentru a fuziona între profile
 · Aplicați suficient DecoFix Ultra în fiecare îmbinare
 · Împingeți puternic profilele una împotriva celeilalte și îndepărtați cu un cutter sau o lama de spaclu excesul de adeziv, înainte de întărire
 · Folosiți FL300 dacă este necesar si finisați cu șmirghel
 · Poate fi vopsit după 24 de ore

Umplutură acrilică ușoară gata de utilizare
 · Pentru finisarea rezistentă la contracție a golurilor (între profile decorative după lipire, între perete și profile, între pereti și între pereti și tavan), fisuri și neregularități în profile sau pe pereti
 · Revopsit rapid (după 15 min.)
 · Nu crapă

Mimořadně silné montážní lepidlo pro porézni povrchy a pro použití v interiéru
 · Silné akrylátové lepidlo na vodní bázi
 · Dlouhodobé spojení mezi listou a stěnou nebo stropem
 · Odstranění pomocí navhčené houbičky nebo hadříku
 · Chraňte před mrazem
 · Po zatvrdnutí přetřítelné (min. za 24 hodin)

Mimořadně silné polymerové lepidlo pro nová výstavba, pro použití v exteriéru, pro neporezní povrchy (dlaždice, sklo...) a vlhke prostředí a 3D nástěnné obložení
 · Odstranění mýdlovým roztokem
 · Po zatvrdnutí přetřítelné (min. za 24 hodin)

Polymerové lepidlo bílé spoj mezi listami
 · Do každé spáry naneste dostatečné množství DecoFix Ultra
 · Profily k sobě silně přitlačte a přebytečné lepidlo před vytvrzením odstraňte malířským nožem
 · V případě potřeby použijte DecoFiller FL300 a přebrušte brusným papírem
 · Lze natírat po 24 hodinách

Lehký akrylový tmel, připravený k použití
 · Pro úpravu spár bez smršťování (mezi dekorativními profily po lepení, mezi stěnou a profily, mezi stěnami navzájem a mezi stěnou a stropem), na praskliny a nedokonalosti profilů nebo stěny a stropu), praskliny a nerovnosti v profilech nebo na stěnách
 · Rychle přetřítelné (po 15 minutách)
 · Nepraská

Tools

ІНСТРУМЕНТИ
 AKCESORIA
 ACCESORII
 PŘÍSLUŠENSTVÍ



FB15

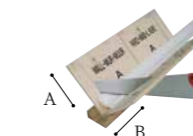

FB300
 A: 29,7 cm | B: 29,1cm

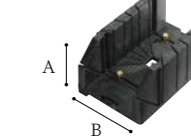

FB13
 A: 12,5 cm | B: 15,5 cm

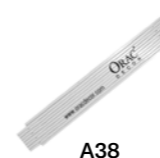

A38

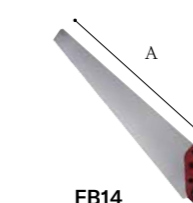

FB14
 A: 60 cm



FB10
 A: 27,5 cm | B: 22 cm

Installation videos & manuals

VISIT WWW.ORACDECOR.COM/INSTALLATION OR SCAN THE QR CODE



Flexible products

ORAC

08

Products

ГНУЧКИ ПРОФІЛІ
PRODUKTY ELASTYCZNE
PRODUSE FLEXIBILE
OHEBNÉ PRODUKTY

You may expect walls to be straight by nature. But we invite you to imagine a flowing interior. Many of our solutions are flexible, following or effectively suggesting a curve in a wall. As far as we're concerned, a rounded corner should never be out of the question.

UA —

Ви могли звикнути до того, що стіни мають бути рівними. Але ми пропонуємо вам уявити інтер'єр з вигинами на стінах. Багато наших профілів є гнучкими, вони повторюють або ефектно підкреслюють непрямі форми. Тому для нас це особливе місце, яке не можна залишити без уваги.

PL —

Można oczekiwać, że ściany będą proste z natury. Zachęcamy jednak, by wyobrazić sobie płynne wnętrza. Wiele z naszych rozwiązań jest elastycznych: podążają one za krzywizną ściany lub skutecznie ją sugerują. Dla nas zaokrąglony narożnik nigdy nie powinien być wykluczony.

RO —

Poate vă așteptați ca pereții să fie mereu drepti. Dar vă lansăm o provocare - imaginați-vă un interior curbat, care „curge”. Multe dintre soluțiile noastre sunt flexibile și urmează - sau chiar sugerează - o linie curbă a unui perete. Pentru noi, un colț rotund nu este de domeniul imposibilului.

CZ —

Možná očekáváte, že stěny budou od podstaty rovné. My vás však vyzýváme, abyste si představili proměnlivý interiér. Mnohá naše řešení jsou flexibilní a sledují nebo efektně naznačují křivku stěny. Protože pro nás by zaoblený tvar stěny neměl být nikdy vyloučen.

| Flex Radius | R min in cm | R* min in cm | R**min in cm | Flex Radius | R min in cm | R* min in cm | R**min in cm | Flex Radius | R min in cm | R* min in cm | R**min in cm |
|-------------|----------------|-----------------|-----------------|-------------|----------------|-----------------|-----------------|-------------|----------------|-----------------|-----------------|
| C211F | 250 | | | CX199F | 200 | | | SX165F | 40 | | |
| C213F | 280 | | | DX174F | 60 | 300 | | SX172F | 35 | | |
| C215F | 160 | | | P3020F | 50 | 180 | | SX173F | 45 | | |
| C217F | 380 | | | P4020F | 40 | 200 | | SX180F | 45 | | |
| C220F | 400 | | | P4025F | 70 | | | SX182F | 35 | 100 | |
| C230F | 150 | | | P5021F | 20 | 70 | | SX183F | 40 | | |
| C240F | 270 | | | P7070F | 30 | 230 | | SX184F | 45 | | |
| C250F | 70 | | | P8020F | 40 | 130 | | SX187F | 40 | | |
| C304F | 250 | | | P8030F | 20 | 70 | | SX194F | 25 | 80 | |
| C321F | 140 | | | P8040F | 30 | | | SX195F | 30 | | |
| C325F | 300 | | | P8050F | 80 | 200 | | W108F | 30 | | 40 |
| C326F | 500 | | | P9010F | 40 | 310 | | W109F | 30 | | 40 |
| C331F | 420 | | | P9050F | 20 | 60 | | W110F | 30 | | 40 |
| C333F | 300 | | | P9900F | 20 | 250 | | W111F | 30 | | 40 |
| C334F | 380 | | | PX103F | 20 | 80 | | W114F | 30 | | 40 |
| C339F | 380 | | | PX120F | 30 | 110 | | W116F | 30 | | 40 |
| C341F | 400 | | | PX144F | 20 | 220 | | W119F | 30 | | 40 |
| C373F | 100 | | | PX175F | 30 | 80 | | W214F | 30 | | 40 |
| C901F | 600 | | | PX198F | 70 | | | WX205F | 30 | | 40 |
| C902F | 600 | | | PX201F | 30 | 80 | | WX210F | 30 | | 40 |
| CX100F | 200 | | | PX202F | 60 | 150 | | WX211F | 30 | | 40 |
| CX106F | 360 | | | PX209F | 20 | 70 | | SX207F | 40 | | |
| CX109F | 160 | | | SX104F | 40 | | | | | | |
| CX110F | 180 | | | SX105F | 30 | | | | | | |
| CX123F | 280 | | | SX118F | 40 | | | | | | |
| CX124F | 160 | | | SX137F | 40 | | | | | | |
| CX127F | 240 | | | SX138F | 40 | | | | | | |
| CX132F | 70 | | | SX155F | 30 | | | | | | |
| CX188F | 110 | | | SX157F | 35 | 260 | | | | | |
| CX189F | 90 | | | SX162F | 20 | 80 | | | | | |
| CX190F | 30 | 130 | | SX163F | 35 | | | | | | |

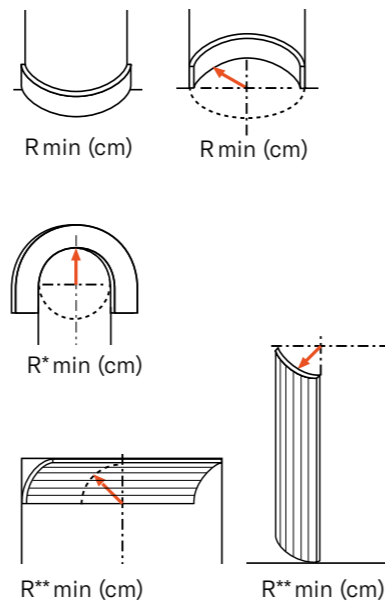

1. W108F p.164

Index

C

| | |
|---------------------|-----------------------------|
| C200 | 69 |
| C201 | 73 |
| C211 C211F | 40, 41, 42, 50, 51, 70, 71 |
| C212 | 73 |
| C213 C213F | 69, 70 |
| C215 C215F | 69 |
| C216 | 69 |
| C217 C217F | 69 |
| C219 | 73 |
| C220 C220F | 69 |
| C230 C230F | 69 |
| C240 C240F | 76 |
| C250 C250F | 76 |
| C260 | 76 |
| C301 | 69 |
| C303 | 73 |
| C304 | 73 |
| C305 | 40, 41, 42, 50, 51, 70, 71 |
| C305 + C211 | 40, 41, 42, 50, 51, 70, 71 |
| C305 + C213 | 70 |
| C307 | 70 |
| C307 + C307A | 70 |
| C307A | 40, 41, 42, 50, 51, 70, 71 |
| C321 C321F | 74 |
| C322 | 69 |
| C323 | 136 |
| C324 | 136 |
| C325 | 67 |
| C326 | 67 |
| C327 | 67 |
| C331 | 73 |
| C332 | 34, 35, 36, 37, 74, 75 |
| C333 C333F | 73 |
| C334 C334F | 73 |
| C336 | 68 |
| C338 | 68 |
| C338A | 68 |
| C338B | 68 |
| C339 C339F | 74 |
| C340 | 74, 83 |
| C341 C341F | 66, 83 |
| C342 | 66, 83 |
| C343 | 46, 47, 52, 53, 66, 83, 117 |
| C344 | 66 |
| C352 | 137 |
| C353 | 80 |
| C354 | 80 |
| C355 | 80, 81 |
| C356 | 80 |
| C357 | 137 |
| C360 | 80 |
| C361 | 145, 146 |
| C362 | 146 |
| C371 | 146 |
| C373 C373F | 144 |
| C374 | 144 |
| C380 | 139 |
| C381 | 139 |

| | |
|------------------------|--|
| C382 | 139 |
| C383 | 139 |
| C390 | 27, 79, 83, 141 |
| C391 | 25, 26, 30, 79, 83, 141 |
| C392 | 27, 79 |
| C393 | 25, 26, 30, 79 |
| C394 | 30, 79, 83, 141, 145 |
| C395 | 79, 83, 141 |
| C396 | 79, 83, 141 |
| C400 | 80 |
| C422 | 70 |
| C602 | 80 |
| C900 | 73, 137 |
| C901 C901F | 73, 137 |
| C902 C902F | 73, 137 |
| C990 | 14, 15, 76, 77 |
| C990 + 2x P9900 | 77 |
| C990 + P9900 | 77 |
| C991 | 77, 81, 83, 145, 146 |
| C991 + 2x P9900 | 31, 77 |
| C991 + P9900 | 77 |
| CB500N | 90 |
| CB501N | 90 |
| CB502N | 90 |
| CB503N | 91 |
| CB510N | 90 |
| CB511N | 90 |
| CB512N | 90, 91 |
| CB520N | 90 |
| CB521N | 90 |
| CB522N | 90 |
| CB523N | 90 |
| CB524N | 91 |
| CB525N | 90 |
| CX100 CX100F | 84 |
| CX106 CX106F | 84 |
| CX107 | 85 |
| CX108 | 85 |
| CX109 CX109F | 86 |
| CX110 CX110F | 84 |
| CX111 | 85 |
| CX112 | 85 |
| CX115 | 86 |
| CX123 CX123F | 84 |
| CX124 CX124F | 84 |
| CX126 | 86 |
| CX127 CX127F | 84 |
| CX129 | 85 |
| CX132 | 86 |
| CX133 | 86 |
| CX134 | 131 |
| CX141 | 86 |
| CX148 | 86 |
| CX160 | 54, 89 |
| CX161 | 89 |
| CX176 | 86 |
| CX177 | 85 |
| CX188 CX188F | 14, 15, 30, 31, 76, 142 |
| CX189 CX189F | 142 |
| CX190 CX190F | 18, 19, 25, 26, 28, 29, 87, 101, 102, 116, 118, 120, 130, 142, 143 |

| | |
|-----------------------|------------------|
| CX192 | 86 |
| CX196 | 83, 87, 102, 142 |
| CX197 | 83, 87, 130, 142 |
| CX199 CX199F | 84 |
| CX203 | 84 |

D

| | |
|----------------------------|---------------------------------|
| D170 | 154 |
| D200 | 154 |
| D210 | 154 |
| D310 | 154 |
| D330LR | 41, 52, 105, 154 |
| D340 | 154 |
| D400 | 155 |
| D401 | 155 |
| D402 | 155 |
| D503 | 155 |
| D504 | 155 |
| D507 | 155 |
| DX119-2300 | 128, 155 |
| DX121-2300 | 128, 155 |
| DX157-2300 | 155 |
| DX163-2300 | 155 |
| DX170-2300 | 41, 52, 105, 112, 128, 154, 155 |
| DX174-2300 DX174F | 128, 155 |

F

| | |
|------------|-----|
| F30 | 107 |
|------------|-----|

K

| | |
|--------------|-----|
| K200 | 157 |
| K201 | 157 |
| K202 | 157 |
| K250 | 157 |
| K251 | 157 |
| K254 | 157 |
| K1001 | 156 |
| K1002 | 156 |
| K1101 | 156 |
| K1102 | 156 |
| K1111 | 156 |
| K1112 | 156 |
| K1121 | 156 |
| K1122 | 156 |
| K1131 | 156 |
| K1132 | 156 |
| K1151 | 156 |
| K1156 | 156 |

P

| | |
|-----------------------|--|
| P20 | 133 |
| P101A | 133 |
| P801C | 133 |
| P1020 | 125 |
| P3020A | 39, 132, 133 |
| P3020 P3020F | 125 |
| P3070 | 126 |
| P3071 | 126 |
| P4020A | 133 |
| P4020 P4020F | 40, 41, 42, 46, 52, 124, 128 |
| P4025 P4025F | 124 |
| P5021 P5021F | 126 |
| P6020 | 125 |
| P7020 | 125 |
| P7030 | 125 |
| P7070 P7070F | 27, 114, 119, 126 |
| P8020 P8020F | 46, 52, 66, 67, 75, 84, 117, 124, 125, 128 |

| | |
|-----------------------|--|
| P8030C | 133 |
| P8030D 133 | |
| P8030 P8030F | 38, 39, 51, 54, 67, 71, 84, 88, 124, 125 |

| | |
|-----------------------|---------------------------------------|
| P8040 P8040F | 124 |
| P8050 P8050F | 39, 50, 124, 125, 132 |
| P8060 | 126 |
| P9010 P9010F | 48, 49, 112, 124, 127 |
| P9020 | 124 |
| P9040 | 124 |
| P9050 P9050F | 48, 49, 112, 126, 127 |
| P9900 P9900F | 24, 31, 77, 126 |
| P9901 | 126 |
| PX103 PX103F | 91, 110, 129 |
| PX103A | 133 |
| PX113 | 129 |
| PX116 | 129 |
| PX117 | 129 |
| PX120 PX120F | 129 |
| PX120A | 133 |
| PX144 PX144F | 129 |
| PX147 | 130 |
| PX169 | 130 |
| PX175 PX175F | 129 |
| PX198 PX198F | 87, 102, 116, 118, 130 |
| PX201 PX201F | 129 |
| PX202 PX202F | 129 |
| PX209 PX209F | 14, 15, 36, 97, 98, 99, 130, 131, 136 |

R

| | |
|------------|-----|
| R07 | 152 |
| R08 | 152 |
| R09 | 152 |
| R10 | 150 |

| | |
|------------|-----|
| R11 | 150 |
| R12 | 150 |
| R13 | 151 |
| R14 | 151 |
| R17 | 151 |
| R18 | 151 |
| R22 | 151 |
| R23 | 151 |
| R24 | 151 |
| R27 | 151 |
| R31 | 151 |
| R40 | 152 |
| R52 | 151 |
| R64 | 151 |
| R73 | 151 |
| R76 | 152 |
| R77 | 152 |

S

| | |
|-----------------------|--------------------------------|
| SX104 SX104F | 115 |
| SX105 SX105F | 112 |
| SX118 SX118F | 93 |
| SX125 | 116 |
| SX137 SX137F | 113 |
| SX138 SX138F | 34, 36, 37, 105, 113 |
| SX155 SX155F | 48, 112 |
| SX156 | 115 |
| SX157 SX157F | 89, 111, 118, 131 |
| SX159 | 126 |
| SX162 SX162F | 89, 111, 118, 131 |
| SX163 SX163F | 89, 111, 118, 131 |
| SX165 SX165F | 111 |
| SX168 | 118, 131 |
| SX171 | 111, 121 |
| SX172 SX172F | 116 |
| SX173 SX173F | 111 |
| SX179 | 116, 142 |
| SX180 SX180F | 25, 27, 30, 114, 119, 139, 140 |
| SX181 | 114, 119 |
| SX182 SX182F | 14, 17, 89, 99, 111, 119, 131 |
| SX183 SX183F | 89, 111, 119, 131 |
| SX184 SX184F | 89, 111, 119, 131 |
| SX185 | 111, 121 |
| SX186 | 111, 121 |
| SX187 SX187F | 114, 119 |
| SX191 | 51, 52, 53, 67, 71, 115 |
| SX193 | 113 |
| SX194 SX194F | 19, 24, 89, 116, 118, 131 |
| SX195 SX195F | 112 |
| SX206 | 46, 113, 128 |
| SX207 SX207F | 26, 95, 118, 130, 131 |
| SX212 | 119, 131 |

W

| | |
|-----------------------|------------------------|
| W100 | 106 |
| W101 | 106 |
| W105 | 106 |
| W106 | 106 |
| W107 | 106 |
| W108 W108F | 96, 165 |
| W109 W109F | 48, 49, 98, 117, 136 |
| W110 W110F | 20, 21, 36, 96, 97 |
| W111 W111F | 25, 87, 101 |
| W112 | 103 |
| W113 | 103 |
| W114 W114F | 18, 19, 98 |
| W116 W116F | 25, 87, 121 |
| W115 | 16, 102, 143 |
| W119 W119F | 25, 87, 121 |
| W120 | 104, 105, 113, 115 |
| W121 | 104, 105, 113, 115 |
| W122 | 104, 105 |
| W123 | 104, 105 |
| W130 | 103 |
| W210 | 98, 136 |
| W213 | 96, 97 |
| W214 W214F | 34, 35, 36, 37, 96, 97 |
| W215 | 34, 35, 36, 37, 96, 97 |
| W216 | 26, 102, 103 |
| W217 | 14, 17, 99 |
| W218 | 14, 17, 99 |
| WX204 | 95 |
| WX204-2600 | 95 |
| WX205 WX205F | 95 |
| WX205-2600 | 95 |
| WX210 WX210F | 36, 95, 97 |
| WX210-2600 | 36, 95, 97 |
| WX211 WX211F | 36, 95, 97 |
| WX211-2600 | 36, 95, 97 |

Colofon

Concept

Base Design
zwerf.studio

Graphic design

zwerf.studio

Special thanks to

| | | |
|-----------------------------------|--------------------------|---|
| BLCN Design | blcn-design.com | 8 |
| The HUB Ghent | thehub.be | 18–19 |
| Maison Numéro 20 | maisonnumero20.fr | 20–21 |
| Atelier DAAA | atelierdaaa.com | 28–29, 88, 120 |
| Marie-Emilie Geerinckx | marieemiliegeerinckx.be | 30–31, 140 |
| Aboco | aboco.be | 38–39, 132 |
| Geoffroy Van Hulle | geoffroyvanhulle.com | 40–41, 42–43, 54–55, 76, 84 |
| Van Damme - Vandeputte architects | vandammevandeputte.com | 50–51, 71, 122, 125 |
| LOFT4C | loft4c.be | 52–53 |
| Anthony Boelaert | anthonyboelaert.be | 68 |
| Interieurprojects | interieurprojects.com | 81 |
| Sur Mesure Interieur | surmesure-interieur.be | 75, 82 |
| Sofie de Kruijff | thehomestyleclub.com | 98 |
| Atelier En Aparté | atelierenaparte.com | 106 |
| Blume Studio | blumestudio.es | 107 |
| Madrid Forest | madridforest.com | 107 |
| Hotel Du Parc Oostende | hotelduparc.be | 110 |
| D-ZAJN | d-zajn.be | 110 |
| Hotel Astoria De Haan | hotelastoria.be | 115 |
| Roelfien Vos | roelfienvos.com | 145, 147 |
| Perfect Living | perfectliving.be | 150 |
| Alina Vilhjálmsdóttir | | 153 |
| Eichholtz | eichholtz.com | 157 |
| Belén Imaz | belenimaz.com | 107 |
| Cafeine | cafeine.be | 18–19, 28–29, 50–51, 71, 88, 115, 120, 122, 125 |
| Damon De Backer | damondebacker.com | 43 |
| Didier Delmas | didierdelmas.com | 20–21 |
| DVO Photographic | dvo-photographic.be | 81 |
| Hannelore Veelaert | hanneloreveelaert.com | 8, 38–39, 110, 132 |
| Lotte van Uittert | lottevanuittert.com | 98 |
| Rebecka Oftedal | | 106 |
| Stephanie Mathias | stephaniemathias.be | 75, 82 |
| Tijs Verweken | tijserverveken.com | 30–31, 40–41, 42–43, 52–53, 54–55, 76, 84, 140 |
| Verne | verne.be | |
| Willem Van Puyenbroeck | willemvanpuyenbroeck.com | 150 |

ORAC Headquarters | nv Orac sa

Biekorfstraat 32
8400 Ostend, Belgium
T +32 59 80 32 52
info@oracdecor.com

ORAC Benelux

Biekorfstraat 32
8400 Ostend, Belgium
NL: T +31 852 08 40 59
BeLux: T +32 59 79 02 82
benelux@oracdecor.com

ORAC Deutschland

Boltensternstraße 159A
50735 Köln, Deutschland
T +49 221 747 499 39
deutschland@oracdecor.com

ORAC Österreich

T +43 662 23 49 27
oesterreich@oracdecor.com

ORAC France

13 Rue Séguier
75006 Paris, France
T +33 188803631
france@oracdecor.com

ORAC Export

T +32 59 79 02 83
export.cs@oracdecor.com

ORAC Slovakia s.r.o.

Kpt. Nalepku 6
08271 Lipany, Slovakia
T +421 232 784 952
slovakia@oracdecor.com

ORAC España

C/ del Rosselló, 229
08008 Barcelona, España
T +34 938 56 49 00
spain@oracdecor.com

ORAC (UK) Ltd.

216 Afon Building, Worthing Road
Horsham, RH12 1TL UK
T +44 1403 240 102
uk@oracdecor.com

Orac Ireland

T +35 381 8000 280
ireland@oracdecor.com

ORAC Italia srl

Corso Giacomo Matteotti, 5/H
23900 Lecco (LC), Italia
T +39 0341 362062
italia@oracdecor.com

ORAC Polska

ul. Pomorska 106A
91-402 Łódź, Polska
T +48 42 203 60 56
polska@oracdecor.com

ORAC Schweiz

T 0800 562 118
switzerland@oracdecor.com

Guarantee terms and conditions apply if provided installation instructions have been followed to the letter. Fire retardant standards. In many interiors and projects strict fire regulations are imposed. Therefore, ORAC has implemented a number of solutions depending on the country and its regulations. Please contact us for more information. The information in this catalogue is without engagement. Changes and discrepancies in sizes or/and shapes against those stated in the catalogue can occur. This catalogue and the design embodied within are protected by copyright law and international treaties. Unauthorized reproduction of the catalogue, any portion of it or the reproduction of the designs embodied therein may result in severe civil and criminal penalties and will be prosecuted to the maximum.

Further legal information can be found on: www.oracdecor.com/nl/disclaimer.



This catalogue is printed on FSC-certified paper.

ORAC PAPER

WWW.ORACDECOR.COM

