

jey feel

Cucina e living caratterizzati da effetti luminosi, vellutati, delicati. Questa è la nuova Jey Feel, progettata per soddisfare le esigenze di chi desidera una cucina moderna con un tocco urban chic. Jey Feel si distingue per i nuovi decorativi: palette materico-cromatiche che consentono di personalizzare al massimo il proprio spazio e di renderlo unico e assolutamente consono alle proprie esigenze. Le basi e le colonne si presentano lisce in diverse essenze e colori, anche abbinabili tra loro grazie alla tenuità delle nuance. Gli elementi a giorno si inseriscono nella composizione creando movimento tra vuoti e pieni. L'ampia offerta di finiture e di dettagli la rendono speciale sotto tutti i punti di vista.

Jey Feel è un concetto di cucina che si esprime in modo semplice e diretto e che coniuga i valori di stile, funzionalità e convivialità propri del Gruppo Lube.





CREO ECOLOGIC

IL GRUPPO LUBE HA SCELTO DI UTILIZZARE PER I COMPONENTI COSTITUENTI LE STRUTTURE DELLE CUCINE SOLO MATERIALE A BASSISSIMA EMISSIONE DI FORMALDEIDE: CONFORMI ALLO STANDARD F4STELLE SECONDO LA NORMA JIS, CERTIFICATO DAL MINISTERO GIAPPONESE, IL PIU' SEVERO IN MERITO ALLE NORMATIVE DI SALVAGUARDIA AMBIENTALE.

Regarding the production of its kitchen structure components, lube group has decided to only use materials featuring very low formaldehyde emissions complying with the 4-star standard, as defined by the jis regulation. This standard is certified by the japanese government-the most rigorous when it comes to environmental protection.

Kitchen and living area characterized by luminous, velvety and delicate effects. This is the new Jey Feel model, designed to meet the needs of those who desire to have a modern kitchen with a urban-chic touch. Jey Feel stands out for its new finish decorations: textured-chromatic palettes that allow customizing the space making it unique and suitable to your own needs. Base units and tall units are smooth in different essences and colors, which is possible to combine thanks to the nuance softness.

Open elements fit into the composition creating dynamism between empty and full. The wide range of finishes and details make it special from all points of view. Jey Feel is a kitchen concept that expresses itself in a simple and direct way, combining all the Gruppo Lube values: style, functionality and conviviality.



CARATTERISTICHE TECNICHE

ANTE E FRONTALI CASSETTI	<p>anta sp. 22 mm in melaminico, finitura real touch fiamma orizzontale nei colori: rovere silver (opz.5306), rovere diamond (opz.5307)</p> <p>anta sp.22 mm in melaminico, finitura materica fiamma verticale (presa maniglia fiamma orizzontale) nei colori: rovere tabià (opz.5309), rovere ortisei (opz.5305)</p> <p>anta sp. 22 mm in melaminico, finitura stone nei colori: black (opz.7863), white (opz.7448)</p> <p>anta sp. 22 mm in melaminico, finitura opaca marmorizzata nel colore: trani (opz.7704)</p> <p>anta sp. 22 mm in melaminico, finitura top matt nei colori: grigio agata (opz.9625), bianco assoluto (opz.7443)</p> <p>anta sp. 22 mm in melaminico, finitura ovatta nei colori: grigio inox (opz.9624), rosso cardinale (opz.8123)</p>
ANTA VETRO	<p>di serie: telaio in alluminio finitura brill sp.22 mm, vetro satinato sp.4 mm, senza maniglia telaio in alluminio finitura selce sp.22 mm, vetro bronzo sp.4 mm, senza maniglia telaio in alluminio finitura silver dark sp.22 mm, vetro satinato sp.4 mm, senza maniglia</p>
MANIGLIA	<p>la presa maniglia è inclusa sull'anta</p>
STRUTTURE DI SERIE	<p>ANTE: ROVERE DIAMOND, BIANCO ASSOLUTO, WHITE nobilitato bianco (opz.001), schiena e ripiano bianco (opz.001)</p> <p>ANTE: TRANI, GRIGIO INOX nobilitato conchiglia (opz.8910) schiena e ripiano conchiglia (opz.8910)</p> <p>ANTE: ROVERE SILVER, GRIGIO AGATA nobilitato argilla (opz.9690) schiena e ripiano argilla (opz.9690)</p> <p>ANTA: ROVERE TABIÀ nobilitato fango (opz.8860) schiena e ripiano fango (opz.8860)</p> <p>ANTE: ROVERE ORTISEI, ROSSO CARDINALE nobilitato visone (opz.948M) schiena e ripiano visone (opz.948M)</p> <p>ANTA: BLACK nobilitato lavagna (opz.9620) schiena e ripiano lavagna (opz.9620)</p>
MENSOLE	<p>di serie: altezza 3,8 cm in laminato bianco (opz.001), conchiglia (opz.8910), argilla (opz.9690), visone (opz.948M), fango (opz.8860), lavagna (opz.9620)</p> <p>a richiesta: altezza 3,8 cm in laminato finiture come ante</p>
ZOCOLI	<p>di serie: altezza 13 cm in pvc ricoperti in melamina finitura acciaio (opz.407)</p> <p>a richiesta: altezza 13 cm in pvc ricoperti in melamina finitura alluminio satinato (opz.405), bianco (opz.001) altezza 13 cm in alluminio liscio finitura brill (opz.412), alluminio finitura titanio ossidato (opz.414), altezza 13 cm in alluminio verniciato a polvere finitura opaca nei colori vedi pag.15</p>



TECHNICAL SPECIFICATIONS

DOORS AND DRAWER FRONT PANELS

door Th. 22 mm, melamine-coated, real touch finish with horizontal grain, available in the following colours: silver oak (opt.5306), diamond oak (opt.5307)

door Th. 22 mm, melamine-coated, textured finish with vertical grain, (handle grip horizontal grain) available in the following colours: tabià oak (opt.5309), ortisei oak (opt.5305)

door Th. 22 mm, melamine-coated, stone finish available in the following colours: black (opt.7863), white (opt.7448)

door Th. 22 mm, melamine-coated, matt marble effect finish available in the following colour: trani (opt.7704)

door Th. 22 mm, melamine-coated, matt worktop finish available in the following colours: agata grey (opt.9625), absolute white (opt.7443)

door Th. 22 mm, melamine-coated, wadding finish available in the following colours: stainless steel grey (opt.9624), cardinal red (opt.8123)

GLASS DOOR

standard: aluminium frame in brill Th.22 mm, satin glass Th.4 mm, without handle
aluminium frame in flint Th.22 mm, satin glass Th.4 mm, without handle
aluminium frame in dark silver Th.22 mm, satin glass Th.4 mm, without handle

HANDLE

the handle grip is included on the door

STANDARD STRUCTURES

DOORS: DIAMOND OAK, ABSOLUTE WHITE, WHITE
melamine-coated white (opt.001), white back panel and shelf (opt.001)

DOORS: TRANI, STAINLESS STEEL GREY
melamine-coated shell (opt.8910), shell back panel and shelf (opt.8910)

DOORS: SILVER OAK, AGATA GREY
melamine-coated clay (opt.9690), clay back panel and shelf (opt.9690)

DOOR: TABIÀ OAK
melamine-coated mud (opt.8860), mud back panel and shelf (opt.8860)

DOORS: ORTISEI OAK, CARDINAL RED
melamine-coated mink (opt.948M), mink back panel and shelf (opt.948M)

DOOR: BLACK
melamine-coated slate grey (opt.9620), slate grey back panel and shelf (opt.9620)

SHELVES

standard: height 3.8 cm, laminate white (opt.001), shell (opt.8910), clay (opt.9690), mink (opt.948M), mud (opt.8860), slate grey (opt.9620)

on request: height 3.8 cm, laminate with same finish as doors

PLINTHS

standard: height 13 cm, melamine-coated pvc with steel finish (opt.407)

on request: height 13 cm, melamine-coated pvc with satin aluminium finish (opt.405), white finish (opt.001)
height 13 cm, smooth aluminium with brill finish (opt.412), aluminium titanium oxidized finish (opt.414),
height 13 cm, aluminium with matt powder coating in the following colours, [see surcharges on page 15](#)

jey feel

cod. **K24**

ante finitura real touch
doors with real touch finish

 *colori in pronta consegna*
available colours

SP. 22 MM TH.22 MM



rovere silver (opz.5306)
silver oak (opt.5306)

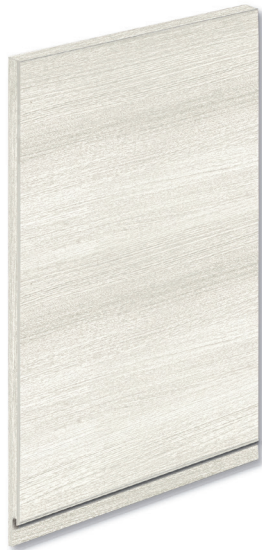

rovere diamond (opz.5307)
diamond oak (opt.5307)

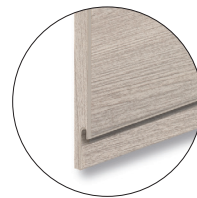
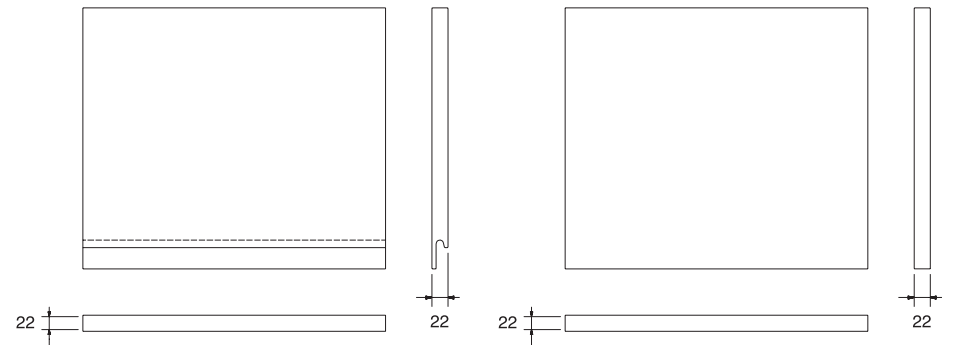

profilo anta tipo "A"
presa maniglia
door profile type "A"
handle grip



profilo anta tipo "C"
pensili apertura con presa su fondo
door profile type "C"
wall units opening with grip on the bottom

A RICHIESTA SOLO PER PENSILI
ON REQUEST ONLY FOR WALL UNITS

ante finitura materica fiamma verticale
doors with textured finish vertical flame

 *colori in pronta consegna*
available colours



rovere tabià (opz.5309)
tabià oak (opt.5309)



rovere ortisei (opz.5305)
ortisei oak (opt.5305)



profilo anta tipo "A"
presa maniglia
door profile type "A"
handle grip



profilo anta tipo "C"
pensili apertura con presa su fondo
door profile type "C"
wall units opening with grip on the bottom

A RICHIESTA SOLO PER PENSILI
ON REQUEST ONLY FOR WALL UNITS

jey feel

cod. **K24**

ante finitura stone
doors with stone finish

 *colori in pronta consegna
available colours*

SP. 22 MM TH.22 MM



black (opz.7863)
black (opt.7863)



white (opz.7448)
white (opt.7448)

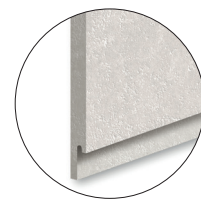
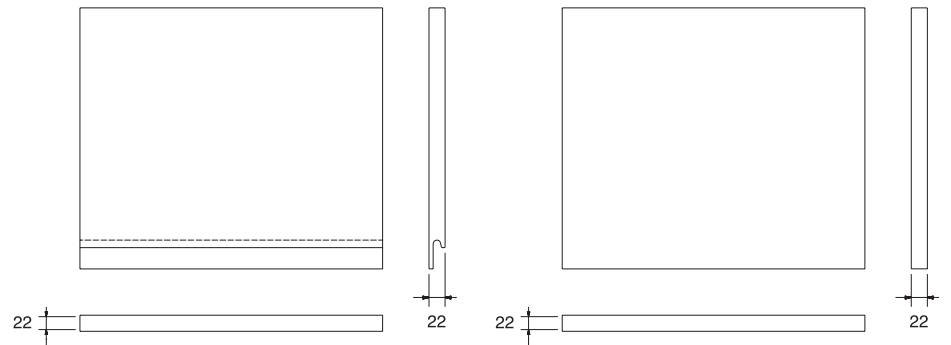

profilo anta tipo "A"
presa maniglia
door profile type "A"
handle grip

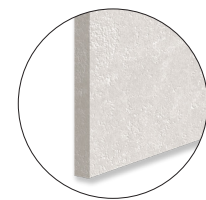

A RICHIESTA SOLO PER PENSILI
ON REQUEST ONLY FOR WALL UNITS

profilo anta tipo "C"
pensili apertura con presa su fondo
door profile type "C"
wall units opening with grip on the bottom

anta finitura opaca marmorizzata
door with matt marble effect finish

 *colori in pronta consegna
available colours*



trani (opz.7704)
trani (opt.7704)



profilo anta tipo "A"
presa maniglia
door profile type "A"
handle grip



A RICHIESTA SOLO PER PENSILI
ON REQUEST ONLY FOR WALL UNITS

profilo anta tipo "C"
pensili apertura con presa su fondo
door profile type "C"
wall units opening with grip on the bottom

jey feel

cod. **K24**

ante finitura top matt
doors with top matt finish

 *colori in pronta consegna
available colours*

SP. 22 MM TH.22 MM



grigio agata (opz.9623)
agata grey (opt.9623)

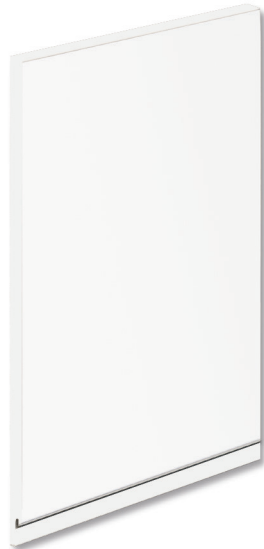

bianco assoluto (opz.7441)
absolute white (opt.7441)

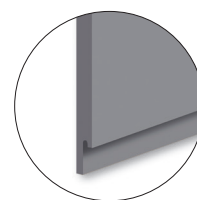
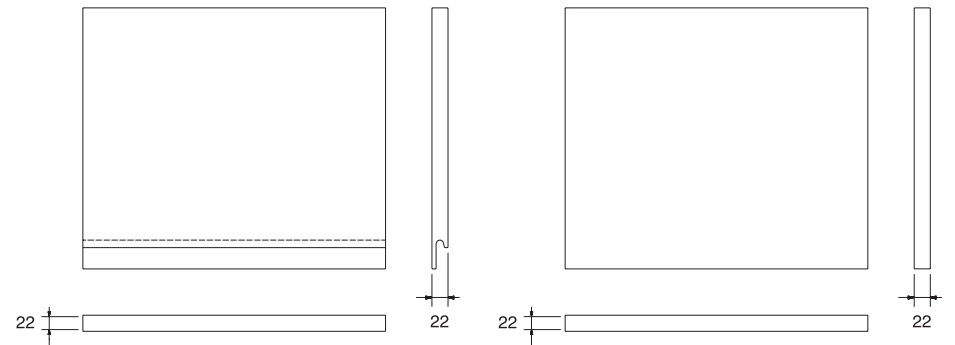

profilo anta tipo "A"
presa maniglia
door profile type "A"
handle grip

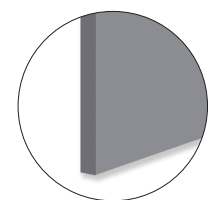

A RICHIESTA SOLO PER PENSILI
ON REQUEST ONLY FOR WALL UNITS

profilo anta tipo "C"
pensili apertura con presa su fondo
door profile type "C"
wall units opening with grip on the bottom

ante finitura ovatta
doors with wadding finish

 *colori in pronta consegna
available colours*

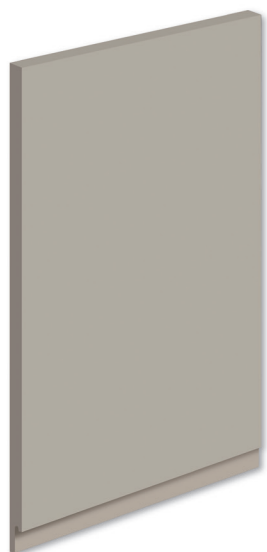

grigio inox (opz.9624)
stainless steel grey (opt.9624)



rosso cardinale (opz.8123)
cardinal red (opt.8123)

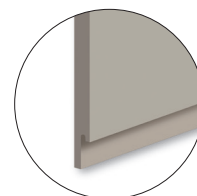

profilo anta tipo "A"
presa maniglia
door profile type "A"
handle grip

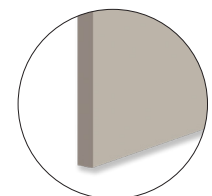

A RICHIESTA SOLO PER PENSILI
ON REQUEST ONLY FOR WALL UNITS

profilo anta tipo "C"
pensili apertura con presa su fondo
door profile type "C"
wall units opening with grip on the bottom

jey feel

cod. **K24**

ante vetro in alluminio
aluminium glass doors

SP. 22 MM TH.22 MM

ANTE VERO
GLASS DOORS

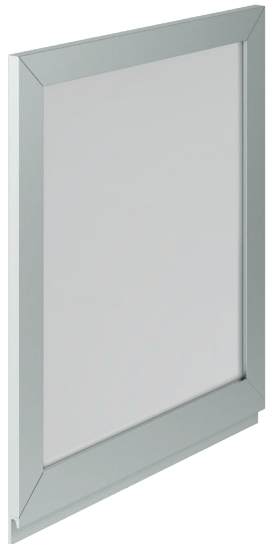

telaio brill con vetro satinato (opz.BRSJ)
brill frame with satin glass (opt.BRSJ)

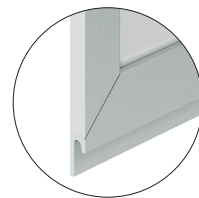
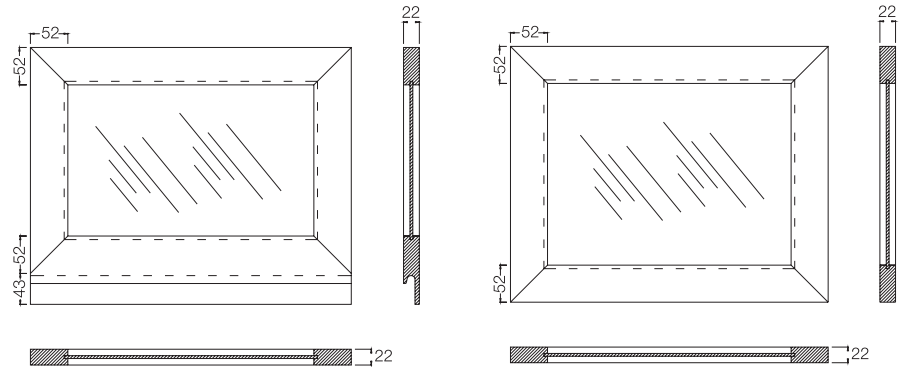

profilo anta tipo "A"
presa maniglia
door profile type "A"
handle grip

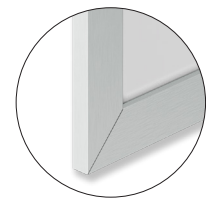

A RICHIESTA SOLO PER PENSILI
ON REQUEST ONLY FOR WALL UNITS

profilo anta tipo "C"
pensili apertura con presa su fondo
door profile type "C"
wall units opening with grip on the bottom

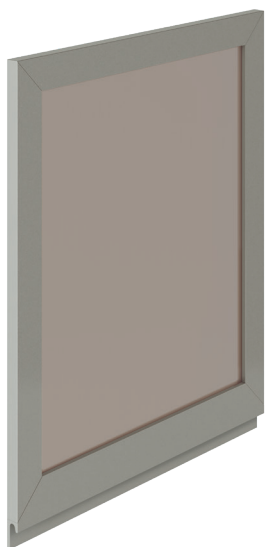

telaio selce con vetro bronzo (opz.SEBJ)
flint frame with bronze glass (opt.SEBJ)



telaio silver dark con vetro satinato (opz.DASJ)
dark silver frame with satin glass (opt.DASJ)

jey feel

strutture carcasses



bianco (opz.001)
schiena e ripiano bianco (opz.001)
white (opt.001)
white back panel and shelf (opt.001)



conchiglia (opz.8910)
schiena e ripiano conchiglia (opz.8910)
shell (opt.8910)
shell back panel and shelf (opt.8910)

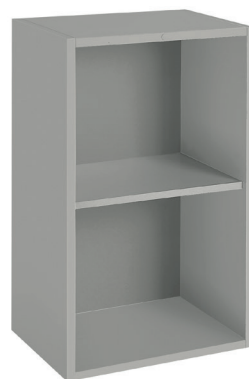

argilla (opz.9690)
schiena e ripiano argilla (opz.9690)
clay (opt.9690)
clay back panel and shelf (opt.9690)

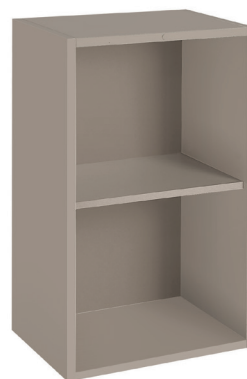

visone (opz.948M)
schiena e ripiano visone (opz.948M)
mink (opt.948M)
mink back panel and shelf (opt.948M)

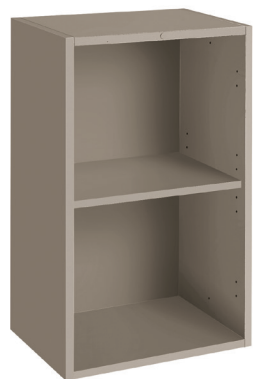

fango (opz.8860)
schiena e ripiano fango (opz.8860)
mud (opt.8860)
mud back panel and shelf (opt.8860)



lavagna (opz.9620)
schiena e ripiano lavagna (opz.9620)
slate grey (opt.9620)
slate grey back panel and shelf (opt.9620)



CREO ECOLOGIC

IL GRUPPO LUBE HA SCELTO DI UTILIZZARE PER I COMPONENTI COSTITUENTI LE STRUTTURE DELLE CUCINE SOLO MATERIALE A BASSISSIMA EMISSIONE DI FORMALDEIDE: CONFORMI ALLO STANDARD F**** SECONDO LA NORMA JIS, CERTIFICATO DAL MINISTERO GIAPPONESE, IL PIÙ SEVERO IN MERITO ALLE NORMATIVE DI SALVAGUARDIA AMBIENTALE.

LUBE GROUP HAS CHOSEN TO EXCLUSIVELY USE MATERIALS WITH VERY LOW FORMALDEHYDE EMISSIONS FOR THE COMPONENTS MAKING UP THE KITCHEN CARCASSES: THESE ELEMENTS COMPLY WITH THE F4 STAR STANDARD ACCORDING TO JIS, CERTIFIED BY THE JAPANESE GOVERNMENT - THE MOST STRINGENT WHEN IT COMES TO ENVIRONMENTAL PROTECTION.

zoccoli in pvc H 13

pvc plinths H 13

di serie
standard



acciaio (opz.407)
steel (opt.407)



alluminio satinato (opz.405)
satin aluminium (opt.405)



bianco (opz.001)
white (opt.001)

zoccoli in alluminio H 13

aluminium plinths H 13



alluminio liscio finitura brill (opz.412)
smooth aluminium with brill finish (opt.412)



alluminio finitura titanio ossidato (opz.414)
aluminium titanium oxidized finish (opt.414)

jey feel

zoccoli in alluminio H 13 verniciati a polvere finitura opaca
aluminum plinths H 13 powder coated matt finish



alluminio finitura bianco assoluto (opz.740S)
aluminium absolute white finish (opt.740S)



alluminio finitura conchiglia (opz.7403)
aluminium shell finish (opt.7403)



alluminio finitura ghisa (opz.9509)
aluminium cast iron finish (opt.9509)

abbinamento consigliato:
recommended combinations

Bianco Assoluto
absolute white
Rovere Diamond
diamond oak
Stone White
white stone

abbinamento consigliato:
recommended combinations

Rovere Ortisei
ortisei oak
Marmorizzato Trani
trani marble

abbinamento consigliato:
recommended combinations

Rovere Tabià
tabià oak



alluminio finitura silver dark (opz.9507)
aluminium dark silver finish (opt.9507)



alluminio finitura grigio selce (opz.SE)
aluminium flint grey finish (opt.SE)

abbinamento consigliato:
recommended combinations

Stone Black
black stone
Grigio Agata
agata grey
Rovere Silver
silver oak

abbinamento consigliato:
recommended combinations

Grigio Inox
stainless steel grey
Rovere Silver
silver oak

mensole in laminato laminate shelves

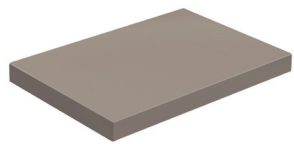

visone (opz.948M)
mink (opt.948M)



bianco (opz.001)
white (opt.001)

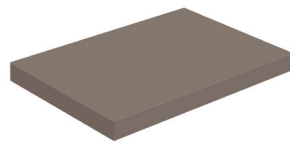

fango (opz.8860)
mud (opt.8860)

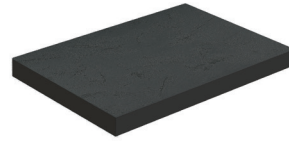

lavagna (opz.9620)
slate grey (opt.9620)

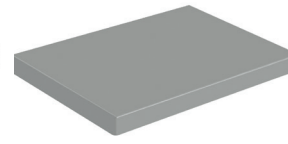

argilla (opz.9690)
clay (opt.9690)

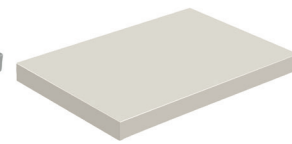

conchiglia (opz.8910)
shell (opt.8910)

mensole in laminato colore come ante laminate shelves same colour as doors



colori come ante
colours same as doors

PENSILI RIBALTA CHIUSURA AMMORTIZZATA

FLAP DOOR WALL UNITS BLUMOTION CLOSING SYSTEM

PENSILE CON APERTURA A RIBALTA

Le ante aprendosi verso l'alto consentono di avere un' ampia visione d'insieme all'interno del mobile. In questo modo è possibile un comodo accesso agli oggetti contenuti al suo interno e, dal punto di vista ergonomico, molto vantaggioso. La regolazione della forza di apertura può essere impostata in modo esatto in base al peso del frontale. Grazie all'arresto progressivo le ante si fermano in qualsiasi posizione; in questo modo la maniglia è sempre facilmente raggiungibile. La chiusura è ammortizzata di serie.

WALL UNIT WITH FLAP DOOR

The doors that open upwards guarantee ample overall visibility inside the cabinet. In this way, all objects housed inside the cabinet can be comfortably accessed, making the system highly advantageous from an ergonomic perspective. The opening force can be adjusted precisely according to the weight of the front. The doors stop in any position thanks to the gradual stopping movement; in this way, the handle is always easily accessible. The closing movement is cushioned standard

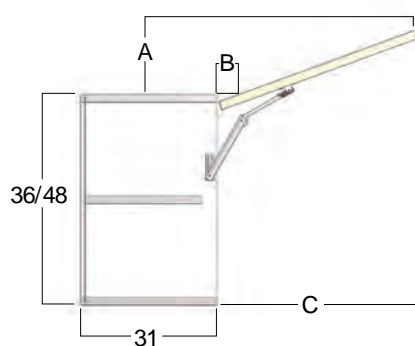

	A	B	C
H 36	7	4	37
H 48	11	4	49

PENSILI APERTURA VERTICALE OBLIQUA CHIUSURA BLUMOTION

WALL UNITS VERTICAL OBLIQUE OPENING AND BLUMOTION CLOSING SYSTEM

APERTURA VERTICALE OBLIQUA

I pensili con questo tipo di meccanismo necessitano per l'apertura di poco spazio libero sopra il mobile grazie al movimento basculante dell'anta che si apre senza difficoltà applicando poca forza anche in presenza di frontali pesanti. Con l'arresto progressivo le ante si fermano in qualsiasi posizione; in questo modo la maniglia è sempre facilmente raggiungibile. La chiusura è ammortizzata ed è possibile regolare la forza di tenuta in base al peso del frontale.

VERTICAL OPENING OBLIQUE

Wall units that mount this type of mechanism require little clearance above the cabinet thanks to the swivelling movement of the door that can be easily opened by applying slight pressure, even with heavy fronts. The doors stop in any position thanks to the gradual stopping movement; in this way, the handle is always easily accessible. The closing movement is cushioned and the closing force can be adjusted according to the weight of the front door.

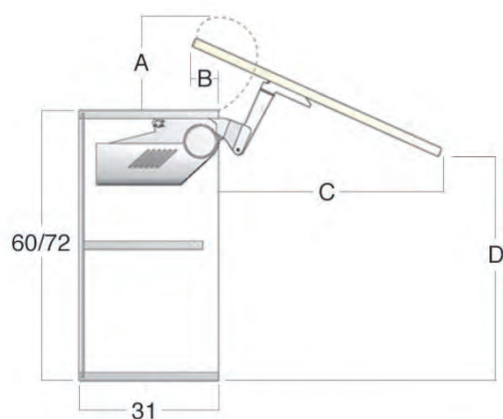

	A	B	C	D
H 60	18	9,6	46,5	53,5
H 72	18	9,6	57	61

PENSILI APERTURA A PACCHETTO

WALL UNITS FOLDING DOORS

PENSILE CON APERTURA ANTE A PACCHETTO

Il meccanismo d'apertura ante a pacchetto è idoneo sia sul pensile H 72 che H 96; la regolazione della forza di apertura può essere impostata in modo esatto in base ai pesi dei frontali, la chiusura è ammortizzata e la cerniera centrale clip si contraddistingue per l'innovativa tecnologia che garantisce la sicurezza per le dita.

WALL UNIT WITH LIFT-UP FOLDING DOORS

The lift-up folding door opening mechanism is suitable for wall units with H 72 or H 96; the opening force can be adjusted precisely according to the weight of the fronts, while the closing movement is cushioned and the central clip-on hinge features innovative technology for safeguarding the fingers.



H 72



H 96

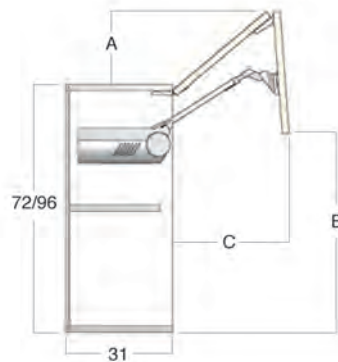

	A	B	C
H 72	16,5	54	41
H 96	20	69	53

SCHEMA MONTAGGIO LIMITATORE LIMITER INSTALLATION DIAGRAM

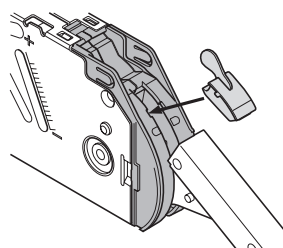
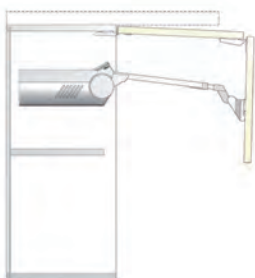

Per evitare l'interferenza dell'anta in fase di apertura con cornici o mensole, si può richiedere il limitatore dell'angolo di apertura cod. 5620005

In order to avoid that the door interferes with cornices or shelves during the opening movement, it is possible to request an opening angle limiter: code 5620005

