

BONALDO

Octa

Designer: **Bartoli Design**



Octa comes from the Greek word “okto” meaning eight: the number of legs that make up the elaborate base of the Octa dining table, metal elements that intersect in an apparently disordered way. This idea arose from playing with Shanghai sticks, an age-old pastime that suggests an idea of chaos and turmoil, lightness and randomness. The top can be fixed or extendable, and is available in a wide range of materials and finishes; in the round version, the table is fixed and made of

glass or ceramic. In the fixed rectangular and barrel versions, veneered and solid wood finishes for the top are available. Its image, in contrast with the base, is sober and linear. The overall result is an almost molecular equilibrium for a decidedly unusual and elegant table, able to characterise the space with a sought-after and contemporary meaning: that of a sign that becomes an object.



Data sheet

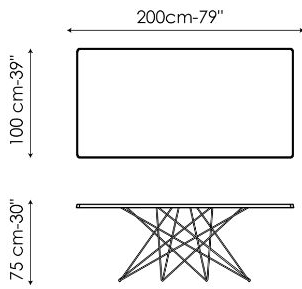

Width: 200cm
Depth: 100cm
Height: ± 75cm

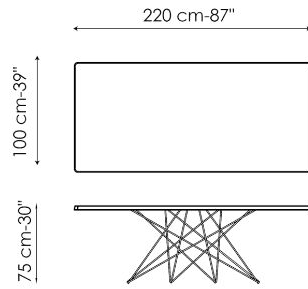

Width: 220cm
Depth: 100cm
Height: ± 75cm

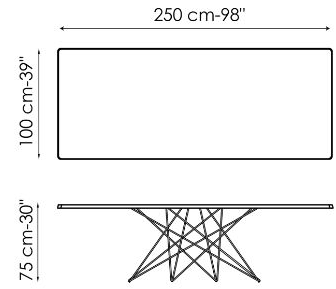

Width: 250cm
Depth: 100cm
Height: ± 75cm

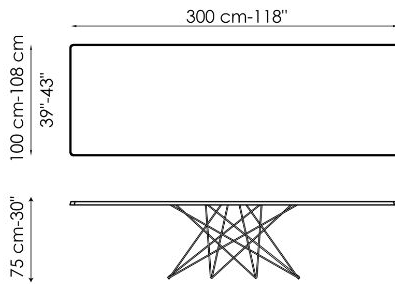

Width: 300cm
Depth: 100-108cm
Height: ± 75cm

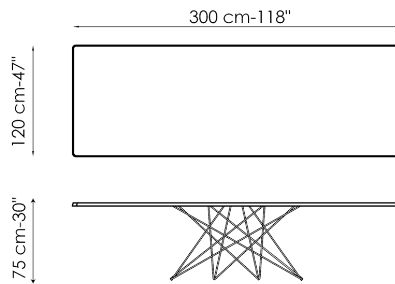

Width: 300cm
Depth: 120cm
Height: ± 75cm

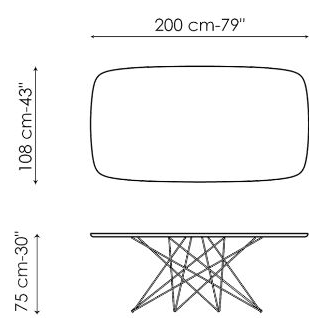

Width: 200cm
Depth: 108cm
Height: ± 75cm

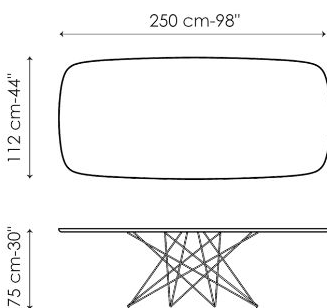

Width: 250cm
Depth: 112cm
Height: ± 75cm

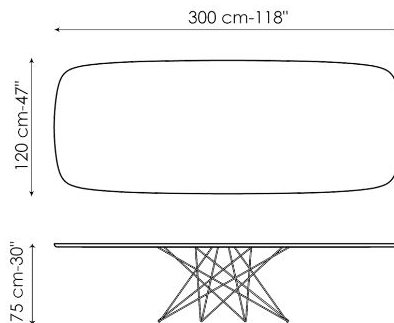

Width: 300cm
Depth: 120cm
Height: ± 75cm

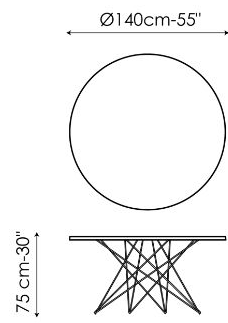

Width: 140cm
Depth: 140cm
Height: ± 75cm

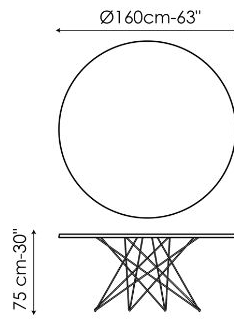

Width: 160cm
 Depth: 160cm
 Height: ± 75cm

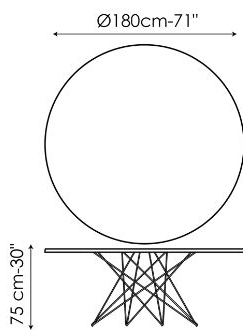

Width: 180cm
 Depth: 180cm
 Height: ± 75cm

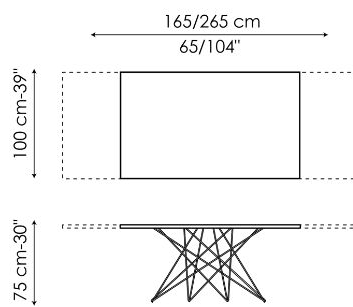

Width: 165-265cm
 Depth: 100cm
 Height: ± 75cm

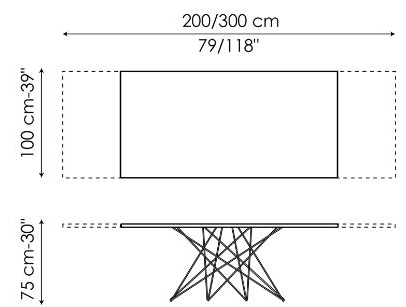

Width: 200-300cm
 Depth: 100cm
 Height: ± 75cm

Finishes

RECTANGULAR TOP

Wood



Solid wood
American walnut



Wood with natural edges
American walnut



Solid wood
Brushed coal oak



Veneered wood
Brushed coal oak



Solid wood
Brushed natural oak



Veneered wood
Brushed natural oak

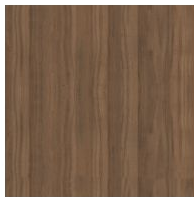

Veneered wood
Walnut Canaletto

Ceramic



Silk finish ceramic
Calacatta macchia
vecchia



Glossy ceramic
Calacatta



Mat ceramic
Iridium white



Mat ceramic
Graphite grey



Mat ceramic
Ardesia grey



Mat ceramic
Laurent



Glossy ceramic
Imperial grey

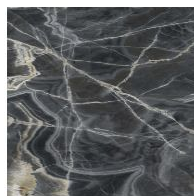

Glossy ceramic
Black Onyx



Glossy ceramic
Mountain peak



Glossy ceramic
Rosso imperiale

BARREL-SHAPED TOP

Wood



Veneered wood
Walnut Canaletto



Solid wood
American walnut



Solid wood
Brushed coal oak



Solid wood
Brushed natural oak

Ceramic



Mat ceramic
Ardesia grey



Glossy ceramic
Calacatta



Silk finish ceramic
Calacatta macchia
vecchia

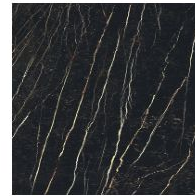

Mat ceramic
Laurent



Glossy ceramic
Imperial grey

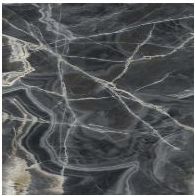

Glossy ceramic
Black Onyx



Glossy ceramic
Mountain peak

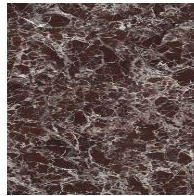

Glossy ceramic
Rosso imperiale



Mat ceramic
Alaska White



Mat ceramic
Augusta

ROUND TOP

Ceramic



Glossy ceramic
Calacatta



Mat ceramic
Ardesia grey



Mat ceramic
Laurent

Transparent Glass



Glass
Bronzed



Glass
Smoked

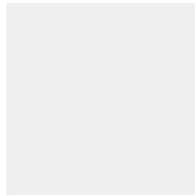

Glass
Transparent

LEAF TABLE TOP

Ceramic



Glossy ceramic
Calacatta

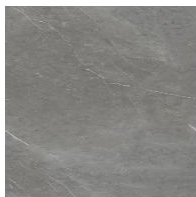

Mat ceramic
Ardesia grey



Mat ceramic
Graphite grey



Mat ceramic
Iridium white

BASE

Metal

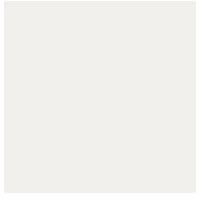

Painted metal
Mat white

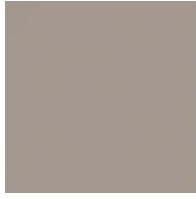

Painted metal
Mat dove grey



Painted metal
Mat brown

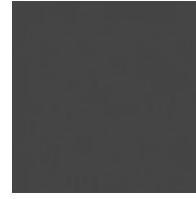

Painted metal
Supreme anthracite



Painted metal
Mat black

Plus Metal



Painted metal
Mat bronze



Painted metal
Mat lead



Painted metal
Mat pearl gold



Painted metal
Mat brass



Painted metal
Mat copper

Special Metal



Metal finish
Black nickel

Materials, fabrics, leathers, colors and finishes are approximate and may slightly differ from actual ones. You can find the complete collection of Bonaldo fabrics and leathers on the website

