

BONALDO

Pil armchair



The Pil armchair is inspired by the object that is itself a symbol of softness, the pillow: usually interpreted as an accessory, here the pillow plays the starring role, shaped and adapted to create the most comfortable armchair that conveys relaxation. The main components of Pil are the backrest cushion and the seat cushion. The latter features a fold in the middle, created to generate an enveloping effect

that physically and visually emphasises the feeling of softness. The base has legs in painted metal or with elegant finishes. The Pil collection, in addition to the armchair, also includes a series of coordinated seats: Pil, (chair), Pil up (chair with high backrest), Miss Pil (chair with armrests), Miss Pil up (chair with high backrest and armrests) and Pil too (stool).



Data sheet

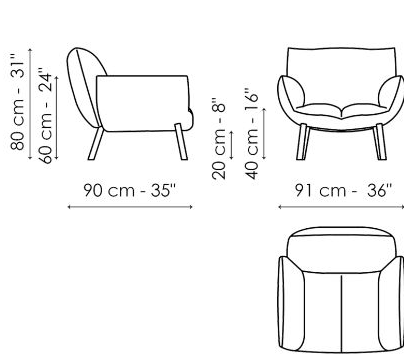

Pil armchair

Width: 91cm
Depth: 90cm
Height: 80cm

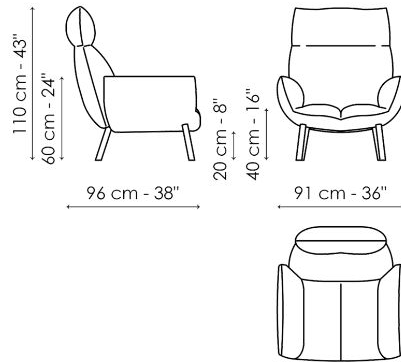

Pil armchair hi

Width: 91cm
Depth: 96cm
Height: 110cm

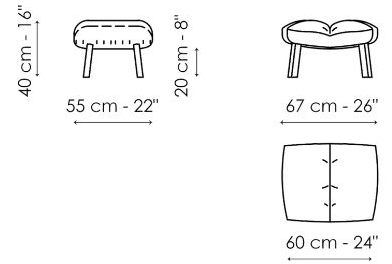

Pil armchair footrest

Width: 55cm
Depth: 67cm
Height: 40cm

Finishes

FEET

Metal



Painted metal
Mat white



Painted metal
Mat dove grey



Painted metal
Supreme anthracite



Painted metal
Mat black

Plus Metal



Painted metal
Mat bronze

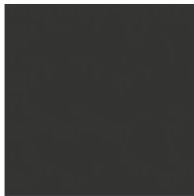

Painted metal
Mat lead



Painted metal
Mat copper



Painted metal
Mat brass



Painted metal
Mat pearl gold

Materials, fabrics, leathers, colors and finishes are approximate and may slightly differ from actual ones. You can find the complete collection of Bonaldo fabrics and leathers on the website

