

ENCORE
ITALIA

ITALIER

ENCORE
ITALIA

A brand that surrounds you with a mix of shapes, colors and materials, that give birth to iconic pieces of furniture enhanced by the classic beauty of the Italian style. Accompanied by the contemporary modernity of an international culture, ENCORE Italia represents a distinctive and elegant stylistic expression for an exclusive space where you can comfortably take refuge in the most complex moments of everyday life.

The environment that surrounds us should make us breathe, relax and create both a comfortable and classy atmosphere. Also, it should reflect our being and constantly make us feel at home, a place where our mind and heart can indulge in the delightful and from which we never want to stray.

To perform this, we value every single detail by our Italian artisans who, through their impeccable craftsmanship and skills, are able to achieve the greatest results in the use of high-quality local materials, giving birth to singular and unique pieces.

Index

Product Gallery	I
Moodboard	
Moodboard 01	pg.08
Moodboard 02	pg.10
Moodboard 03	pg.12
Spaces	
Dining	
Dining 01	pg.16
Dining 02	pg.20
Dining 03	pg.24
Living	
Living 01	pg.30
Living 02	pg.32
Living 03	pg.36
Bedroom	
Bedroom 01	pg.42
Bedroom 02	pg.46
Bedroom 03	pg.50
Products	
Tables	pg.56
Chairs	pg.68
Dressers	pg.74
Sofa	pg.82
Beds	pg.88
Accessories	pg.94
Datasheet	pg.104

E3

E3

Product Gallery







V



VI



VII



VIII























XXIX



XXX





XXXIII



XXXIV





XXXVII



XXXVIII





XLI



XLII



XLIII



XLIV



XLV



XLVI



XLVII



XLVIII



XLIX

L

Moodboards



Moodboard 01



Moodboard 02



Moodboard 03

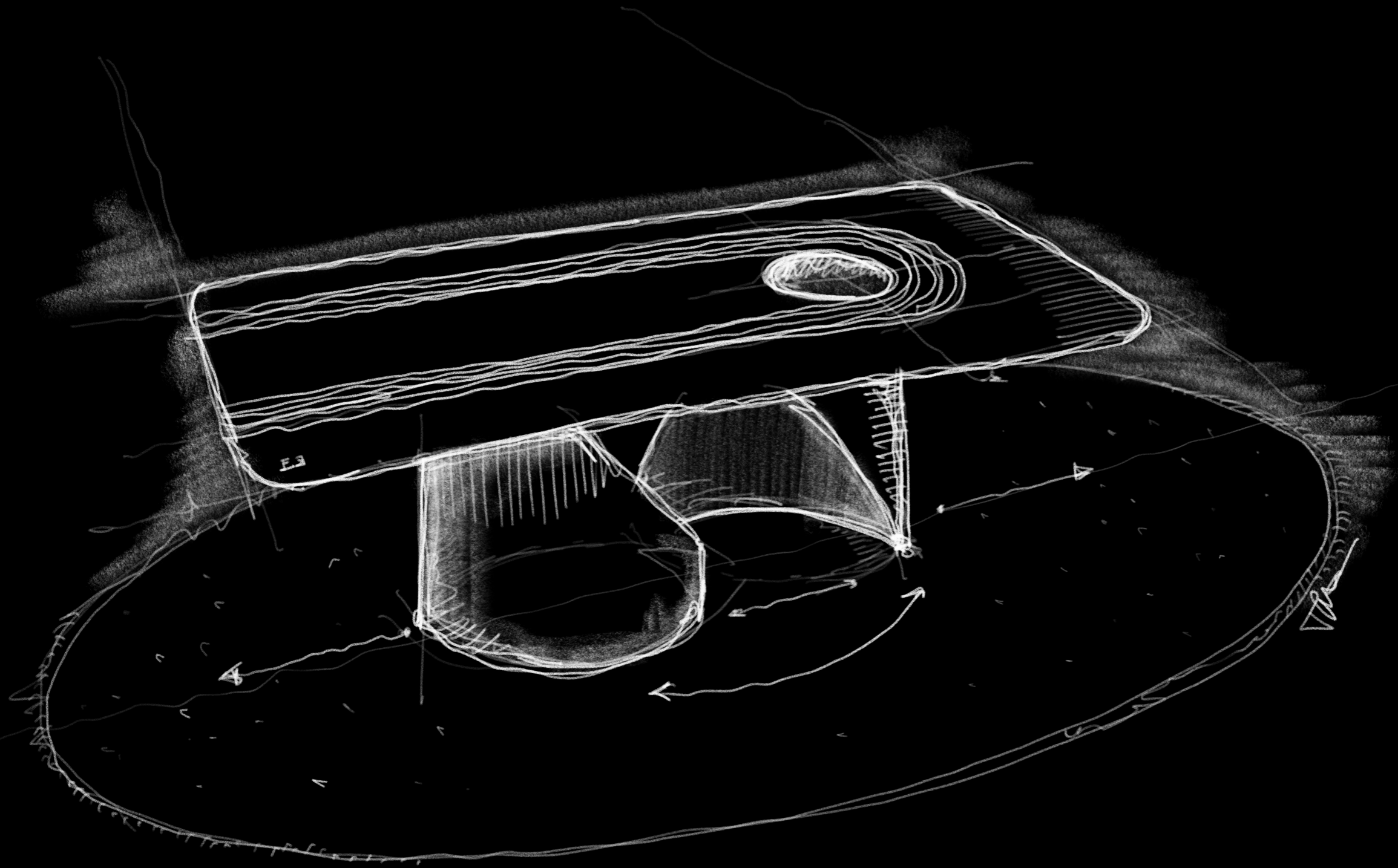

Diningrooms



Dining 01



Set design

Table - Tholos **pg.58**

Chairs - C-Chair **pg.70**

Consolle - Torii **pg.66**



Dining 02



Set design

Table - Tholos **pg.56**

Chairs - Bonnet **pg.72**

Console - Focus **pg.76**



Dining 03



Set design

Table - Torii

pg.64

Consolle - Focus

pg.76

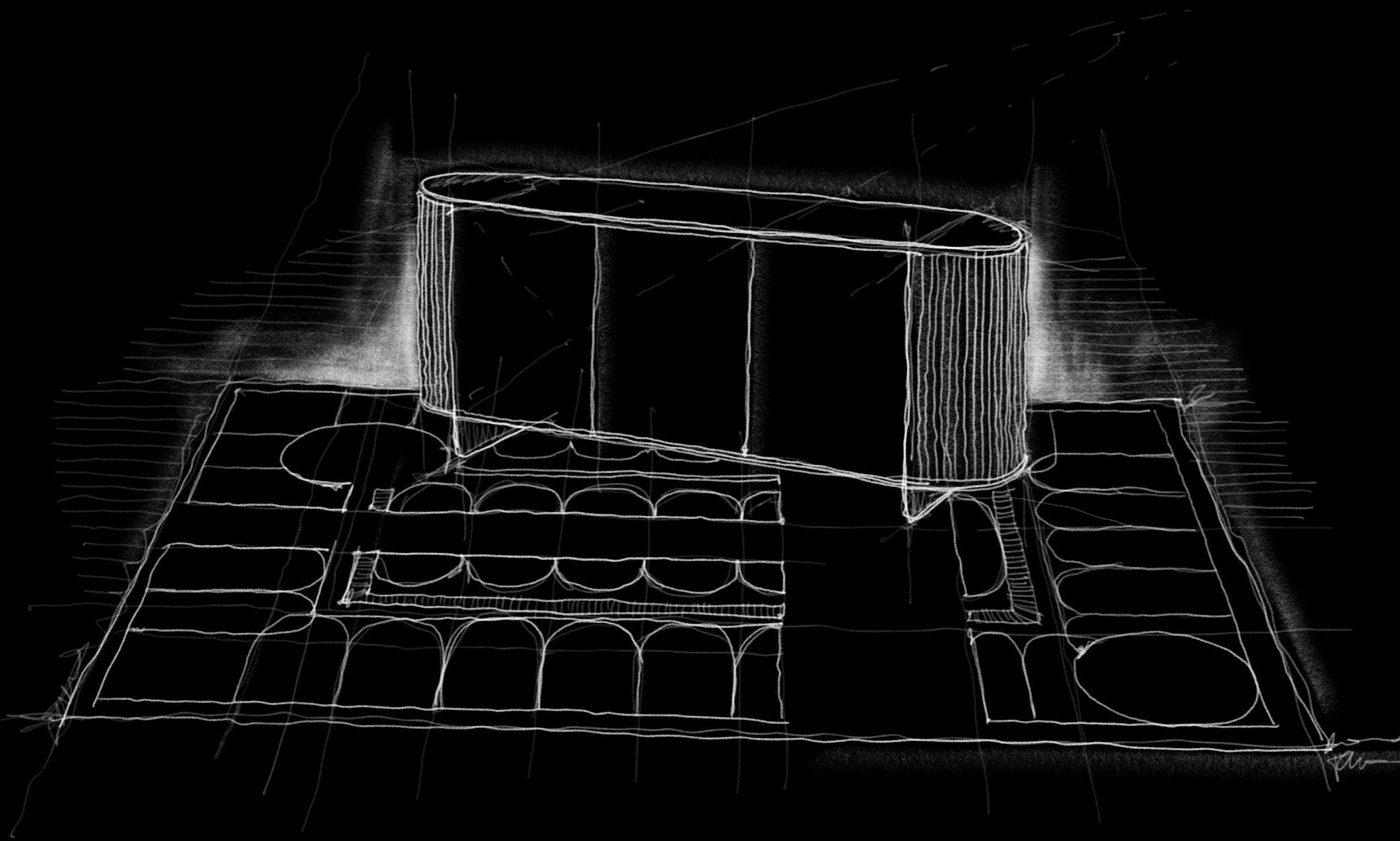

Livingrooms



Living 01

Set design

Console - Dobos

pg.74

Chair - Michelia

pg.86



Living 02



Set design

Tables - Tholos pg.60

Sofa and Armchairs - Nest pg.82

Console - Dobos pg.74

Mirror - Bolla pg.94

Carpet - Illusion Black pg.100



Living 03



Set design

Tables - Osiris pg.62

Sofa and Pouf - Nest pg.82

Consolle - Paradigma pg.92

Mirror - Bolla + Echo pg.94/96

Carpet - Central Park pg.98

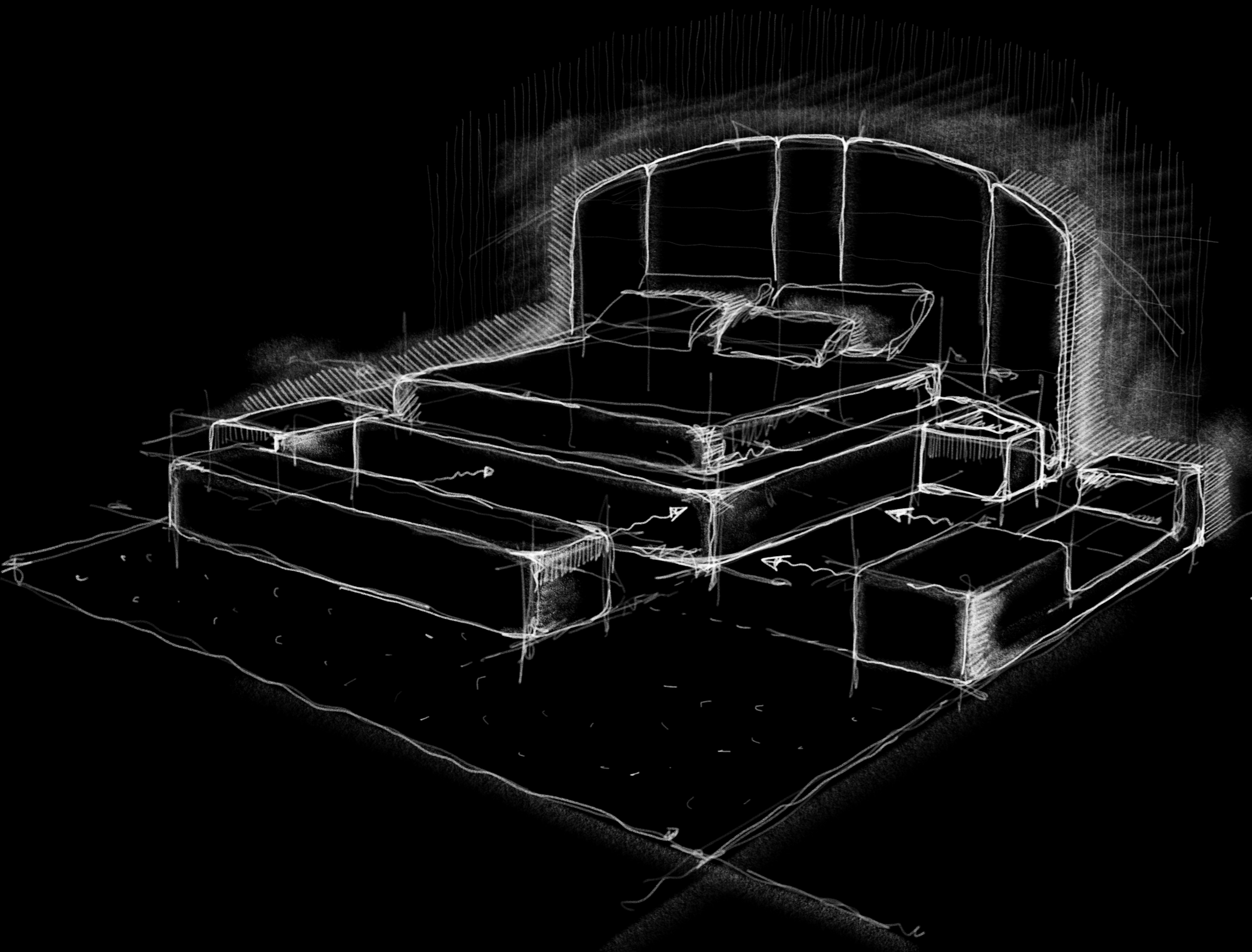

Bedrooms



Bedroom 01



Set design

Bed - Concept 01

pg.88



Bedroom 02



Set design

Bed - Concept 01 pg.88

Dresser and Console - Echo pg.78/80

Mirror - Echo pg.96

Pouf - Matisse pg.84

Carpet - Illusion Black pg.100



Bedroom 03



Set design

Bed - Sophisma

pg.90

Console and Nightstand - Paradigma

pg.92

Products

Tholos

Double leg table

For a charming dining area solution, Encore presents an elegant rectangular table. Two curved metal plates are the pillars on which the rectangular top in precious ebony, glass or lacquered rests. The table characterized by a material contrast between the metal base and top finishes.

Design by LATOxLATO

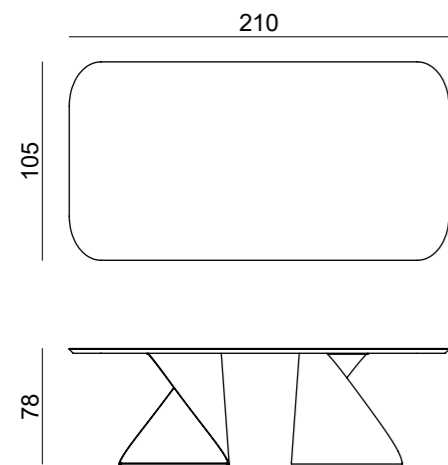

Set design pg. 20-22
Technical details and more information pg. 104

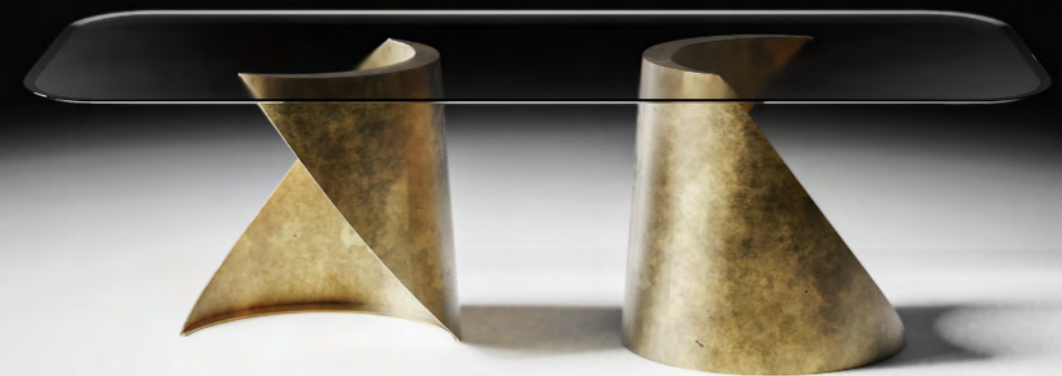

Tholos

Central single leg table

For a charming dining area solution, Encore presents an elegant round table. Two curved metal plates are the pillars on which the round top in precious ebony, glass or lacquered rests. The table characterized by a material contrast between the metal base and top finishes.

Design by LATOxLATO

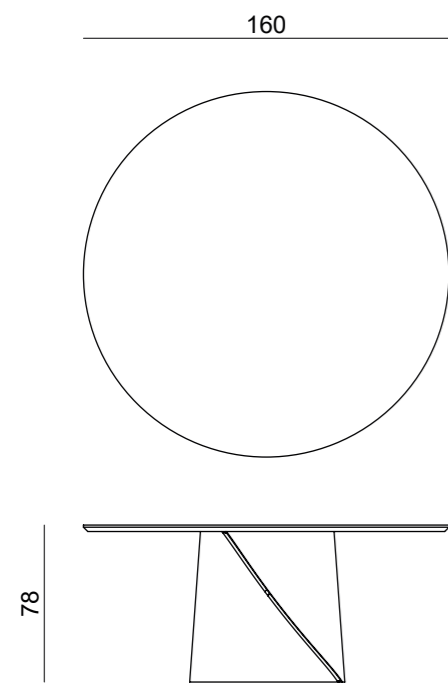

Set design pg. 16
Technical details and more information pg. 104

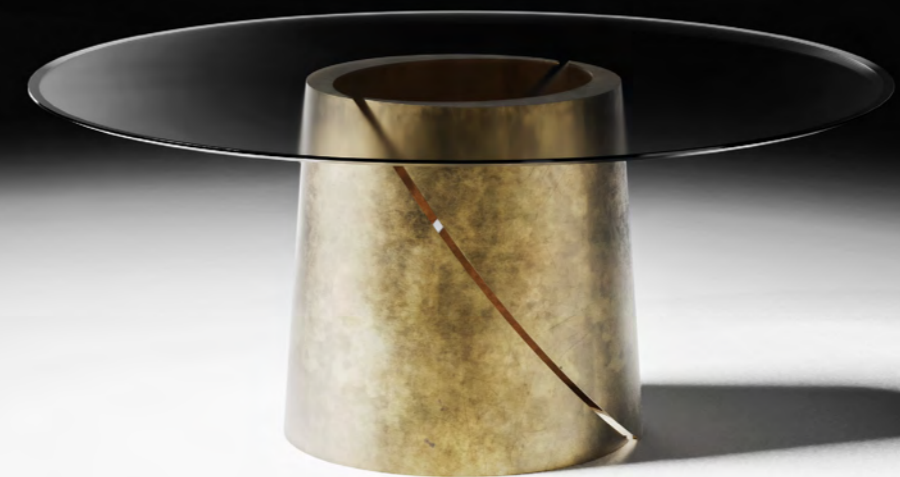

Tholos

Side tables and low tables collection

For a charming living area solution, Encore presents an elegant set of small tables. Two curved metal plates are the pillars on which the top in precious ebony, glass or lacquered rests. The tables are characterized by a material contrast between the metal base and top finishes.

Design by LATOxLATO

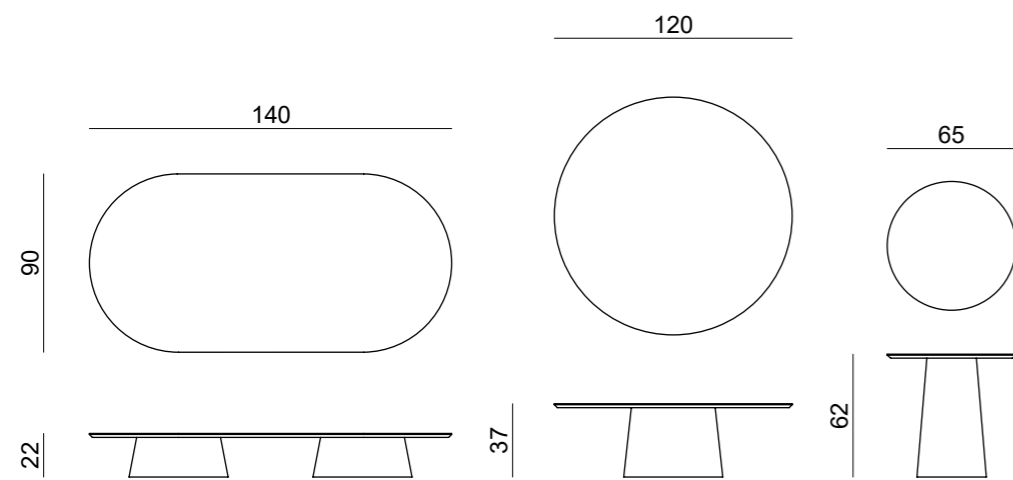

Set design pg. 32-35
Technical details and more information pg. 104



Osiris

Side table and low table collection

With its glossy, opulent appearance, Osiris is the perfect low table, versatile enough with its height, it is the right choice for every space to be placed right in front of a sofa or next to an armchair or even paired with some cushions on the floor for a traditional oriental dinner.

Osiris was thought in a gold looking finish, with a customizable top material.

Design by LATOxLATO

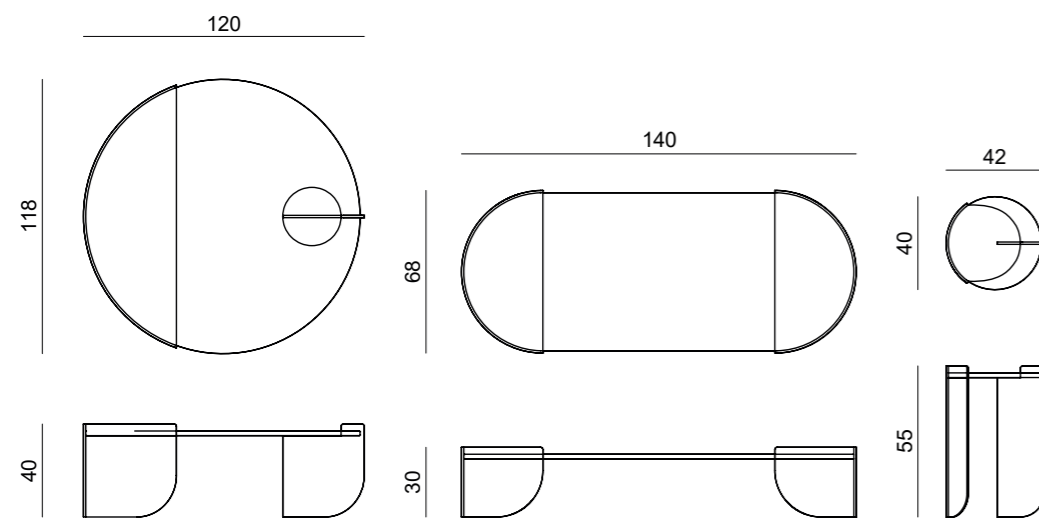

Set design pg. 36-38
Technical details and more information pg. 104



Torii

Central double leg table

The inspiration for the Torii table comes from the clean, sculptural lines of the ancient Japanese gates that littered the sacred, meditative spaces of sanctuaries. With this luxury reinterpretation, we wish to bring a piece of the same peaceful and imposing presence in our environments.

As for tradition, it is made in a wooden finishing, but with some brass accents to add some unique feature to its very essential design.

Design by LATOxLATO

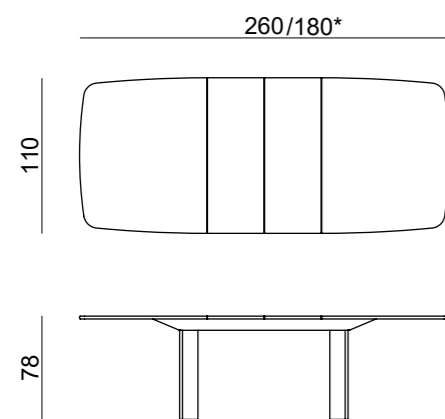

*Extendable table

Set design pg. 24-27

Technical details and more information pg. 105



Torii

Double leg console

The inspiration for the Torii console comes from the clean, sculptural lines of the ancient Japanese gates that littered the sacred, meditative spaces of sanctuaries. With this luxury reinterpretation, we wish to bring a piece of the same peaceful and imposing presence in our environments.

As for tradition, it is made in a wooden finishing, but with some brass accents to add some unique feature to its very essential design.

Design by LATOxLATO

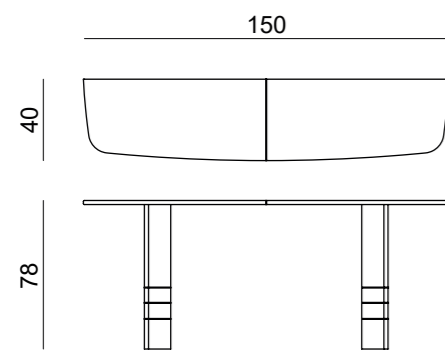

Set design pg. 16-18
Technical details and more information pg. 105



T-Chair

Upholstered chair

With its formal, essential lines, T-chair is a modern take on a classic model. Made to bring a touch of luxury to the table, it gets its name from the elegant T shape of its back. In its simplicity, it is probably one of the most iconic pieces. Available in a vast array of textiles and metal finishings, it can easily conform to your interior design style.

Design by LATOxLATO

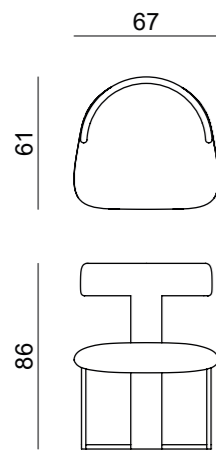

Technical details and more information pg. 105



C-Chair

Upholstered chair

C-chair is a lower back interpretation of a modern chair. It brings its modest height to the table, ensuring a minimalist appearance while still offering lumbar support. C-chair derives its name from the upper shape of its seat. Available in a vast array of textiles and metal finishings, it can easily conform to your interior design style.

Design by LATOxLATO

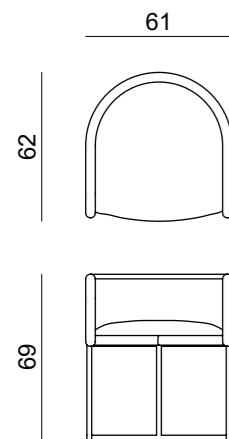

Set design pg. 16
Technical details and more information pg. 105



Bonnet

Upholstered chair

The bonnet is the iconic headpiece every Victorian woman need in her wardrobe. Often lined in high quality materials, no outfit was complete without one. Made in a classical shape for everyday use, Bonnet is the right chair to blend in every room.

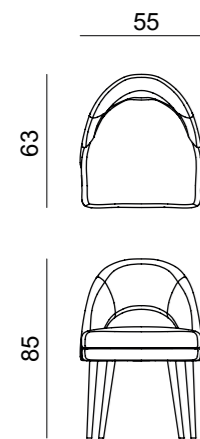

Set design pg. 20-22
Technical details and more information pg. 105



Dobos

Dresser

Rounded appearance and even layers, the Dobos sideboard is a tribute to the famous chocolate cake. With its Soft looks, this piece was developed to bring an organic element to the room. It is available in multiple wood or lacquered finishes.

Design by LATOxLATO

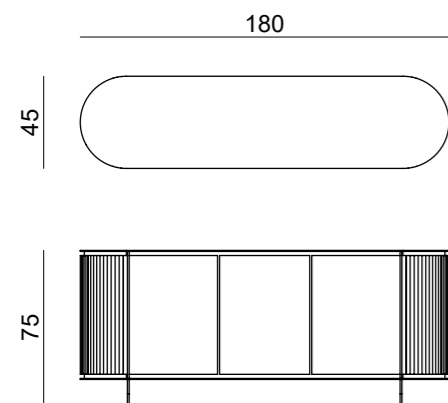

Set design pg. 30-35
Technical details and more information pg. 106



Focus

Dresser

This sideboard gets its inspiration from the roman fireplace, a staple in the tradition of every ancient house. In roman times, no living space could exist without one. Focus sideboard, with its warm essences is going to bring warmth and coziness to the room. Focus is available in an array of wood finishes with brass details.

Design by LATOxLATO

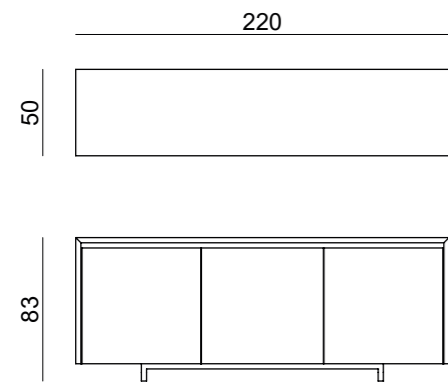

Set design pg. 25-27
Technical details and more information pg. 106



Echo

Dresser

Named after the nymph, Echo Dresser is a resonance of Italian luxury and love for details. It is the perfect commistion of a sharp, clean concept, rounded by an organic, sanded silhouette. Like a river stone smoothed by the currents, Echo Dresser shines of a natural, matte texture rendered with a fine lacquered finish.

Design by LATOxLATO

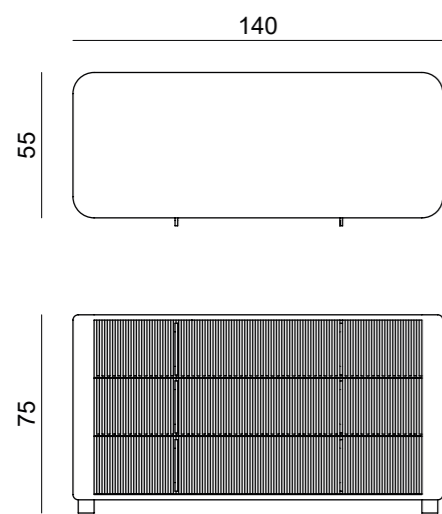

Set design pg. 47-49
Technical details and more information pg. 106



Echo

Console with mirror

Named after the nymph, Echo Vanity is a resonance of Italian luxury and love for details. It is the perfect commistion of a sharp, clean concept, rounded by an organic, sanded silhouette. Like a river stone smoothed by the currents, Echo Vanity shines of a natural, matte texture rendered with a fine lacquered finish.

Design by LATOxLATO

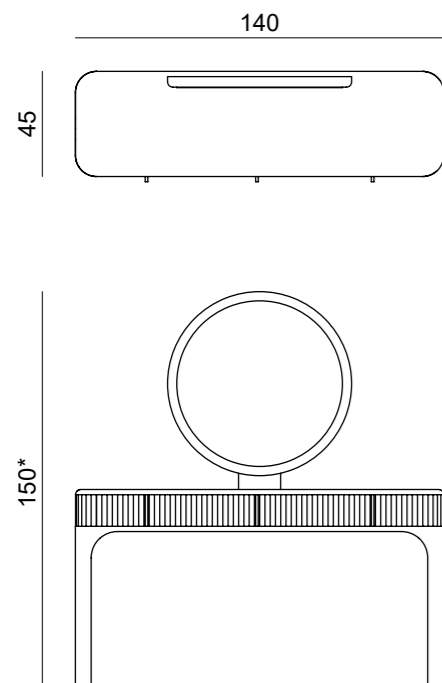

*Mirror included

Set design pg. 46

Technical details and more information pg. 106



Nest

Sofa collection

Drawn from the florid, luscious fields of Italian hillside. The Nest sofa collection has its inspiration in the edelweiss flowers spontaneously dotting the grazings in clusters of fluffy white stars. With its softness, organic shape and durable materials, it is made to transform every space in a cozy environment.

As a tribute to the plant, the collection was originally thought to be made in the same velvet material and its complemented by a rounded brass base.

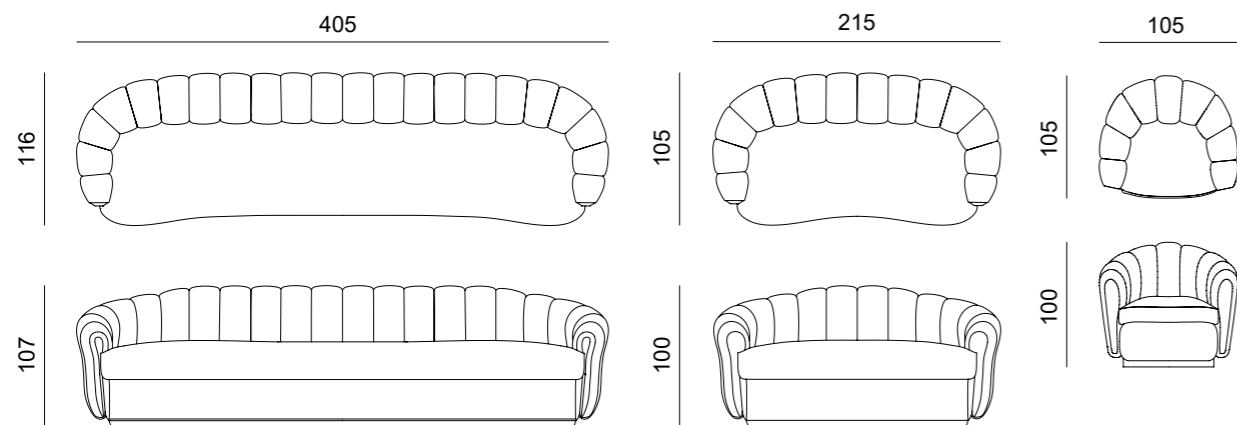

Set design pg. 32-38
Technical details and more information pg. 107



Matisse

Sofa collection

Matisse was the main esponent of the fauvism, a pittoric current that deeply influenced the simple lines and strong colors of this eclectic collection.

Organic in nature, it brings its sinous lines into the livingroom, with the aim to soften the sharp, straight lines of our environments. Matisse comes in a wide variety of finitures, but always with metal insertions.

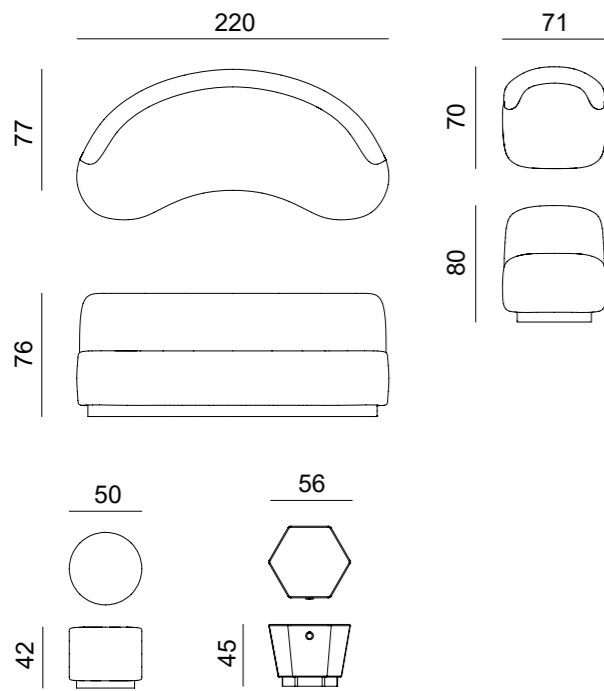

Set design pg. 39-46
Technical details and more information pg. 107



Michelia

Upholstered armchair

From the soft glow of a flowering magnolia tree, this armchair was inspired by the stark contrast of the off-white flowers and the rich brown of the branches. Studied for comfort, it makes a nice addition to any corner, giving this armchair the potential to become the most used piece of the livingroom. Michelia is dressed in buclè paired with high quality Italian wood.

Design by LATOxLATO

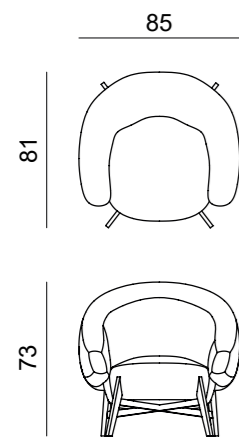

Set design pg. 30
Technical details and more information pg. 108



Concept 01

Double bed

This bed was born from the need for an element that could adapt to all situations, from private to contract. For this reason, a study was made to support modules that would give the possibility of a system and a simple bed. The various options of aggregation of the elements allow it to adapt to any environment in which it is inserted.

The intimate and cosy space expresses the elegance and refinement of a domestic luxury, enhanced by the olive green colour. For sleeping, relaxing, regaining energy, reading, meditating, dreaming, feeling at home. Sophisticated allure and modern charm for the Concept 01 bed.

Design by LATOxLATO

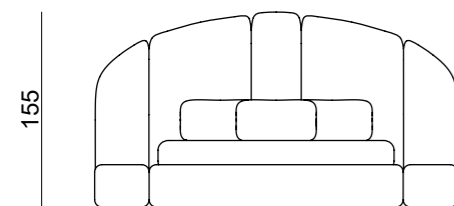
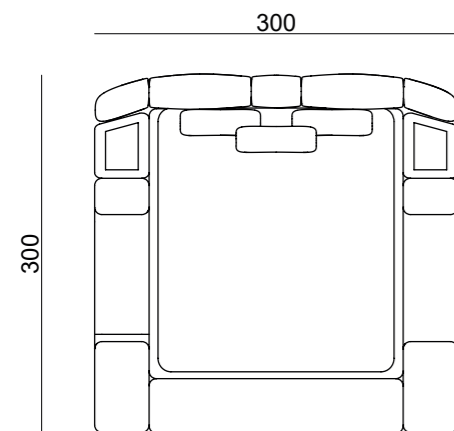

Set design pg. 42-48

Technical details and more information pg. 108



Sophisma

Double bed

From the Greek Sophos: Wise, clever, this bed is a synthesis of curved lines and soft edges, made to resolve a complex process into a simple appearance while still maintaining all of its opulence. Sophisma, with its freestanding headboard, it's more than just a simple bed, it is a 360° artwork for your bedroom.

Made of nabuk leather and opaque hardwood with brass finishings, it is a modern take on what Italian tradition suggests.

Design by LATOxLATO

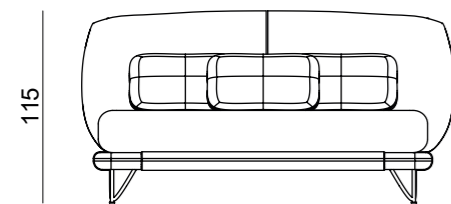
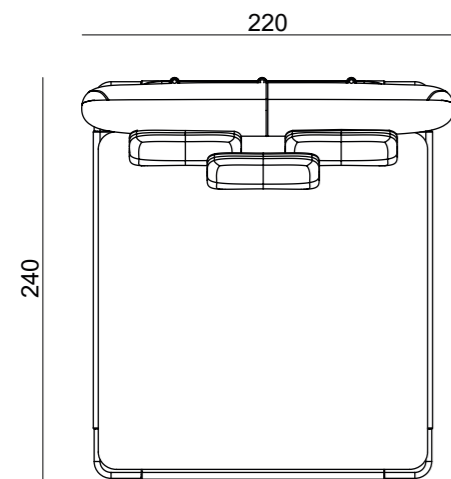

Set design pg. 50-52

Technical details and more information pg. 108



Paradigma

Side table and cosolle collection

With its soft, essential lines, Paradigma is, as its name suggests, the epitome; the perfect example of its kind. With this philosophical interpretation of the Italian countryside, this collection has been realized to bring the best of Italian materials and craftsmanship into your houses. Paradigma collection is made of hardwood and nabuk leather, two very simple materials to ennoble a very clean, functional design.

Design by LATOxLATO

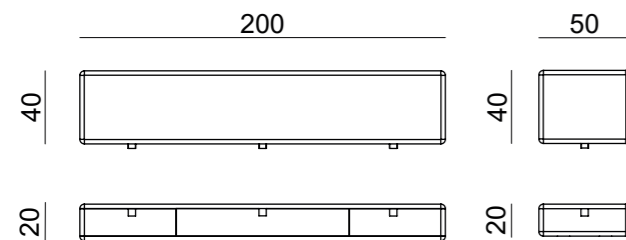

Set design pg. 37-39/50-53
Technical details and more information pg. 109



Bolla

Floating wall mirror composition

Evoking the ephemeral, light sphere of soap fluctuating in the sky, this mirror is aiming to immortalize the fleeting image of a bubble and of the reflexes cast from the sun on its outer edges, bringing back the playful moments of life. Bolla is made in brass and glass, to mimic the interaction of the sun with a bubble surface.

Design by LATOxLATO

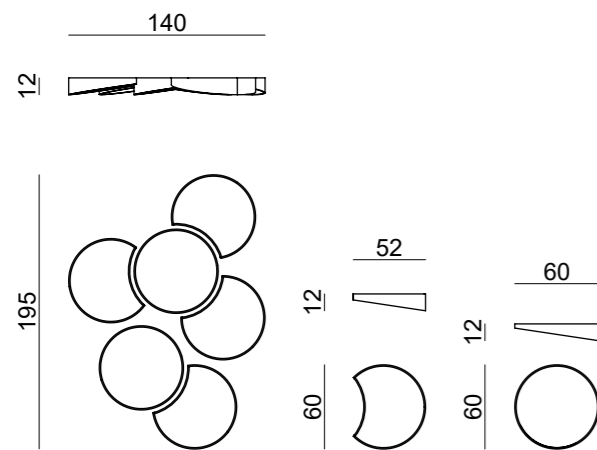

Set design pg. 32-34/37-39
Technical details and more information pg. 109



Echo

Floating wall mirror

Named after the nymph, Echo Mirror is a resonance of Italian luxury and love for details. It is the perfect commistion of a sharp, clean concept, rounded by an organic, sanded silhouette. Like a river stone smoothed by the currents, Echo Mirror shines of a natural, old brass texture.

Design by LATOxLATO

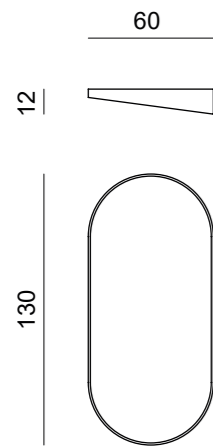

Set design pg. 37-39/47-49
Technical details and more information pg. 106

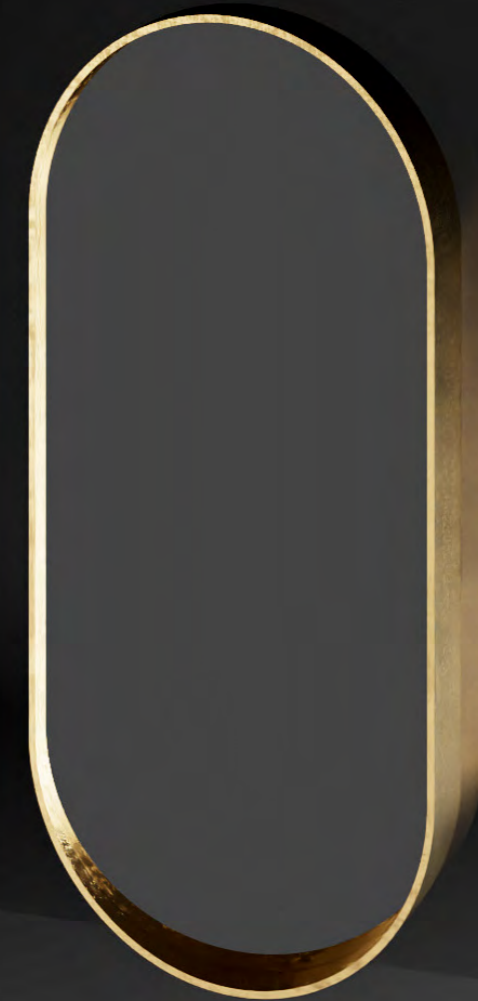

Central Park

Hand-knotted carpet

From the topiary art of NYC, This carpet aims to bring our houses the feeling of nature and manmade landscape. Central park is bringing a part of the same relief we feel when we are surrounded by plants.

Design by LATOxLATO

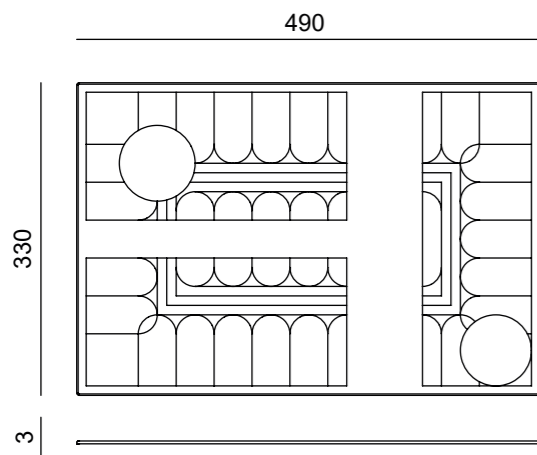

Set design pg. 36-38
Technical details and more information pg. 109

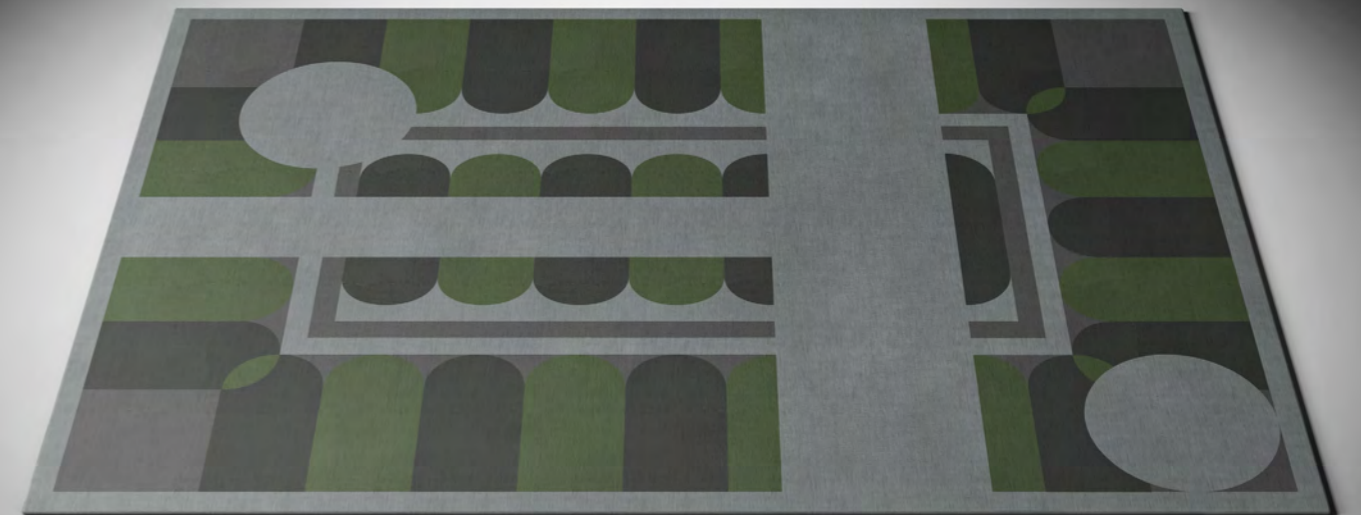

Illusion Black

Hand-knotted carpet

Drawing inspiration from the intersection, blend and movement of changing shapes, Illusion carpets aims to represent the pattern of an artistic mind. Warm and soft, Illusion carpet is made to blend with the other pieces of the catalog and let them shine.

Design by LATOxLATO

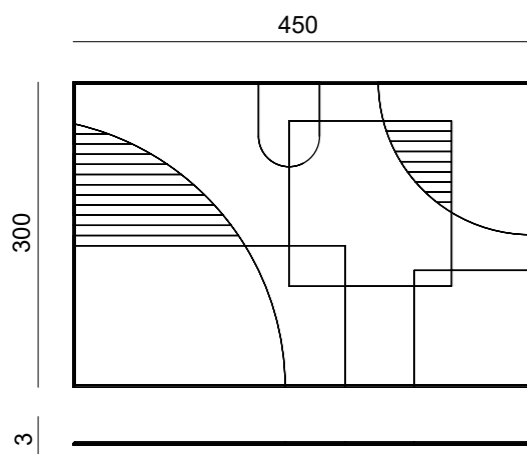

Set design pg. 32-35/46-48
Technical details and more information pg. 109

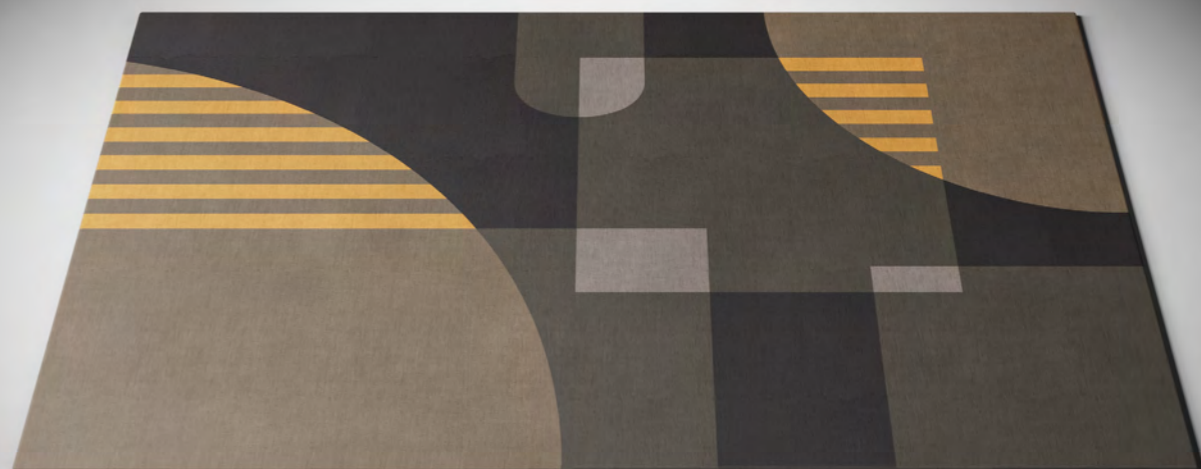





E3

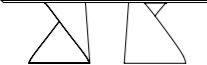

E3

Datasheet

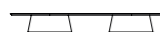

Tholos

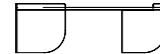
		codes:	materials:	dimensions:
PG. 56		ETH001 ETH002	Top: Wood/Glass Base: Metal	L.210 x P.105 x H.78 cm L.240 x P.120 x H.78 cm ON REQUEST
PG. 58		ETH003	Top: Wood/Glass Base: Metal	ø160 x H.78 cm
PG. 60		ETH301	Top: Wood/Glass Base: Metal	ø65 x H.62 cm
PG. 60		ETH302	Top: Wood/Glass Base: Metal	ø120 x H.37 cm
PG. 60		ETH303	Top: Wood/Glass Base: Metal	L.140 x P.90 x H.22 cm

Osiris

		codes:	materials:	dimensions:
PG. 62		EOS301	Top: Glass Base: Metal	L.140 x P.68 x H.30 cm
PG. 62		EOS302	Top: Glass Base: Metal	L.120 x P.118 x H.40 cm
PG. 62		EOS303	Top: Glass Base: Metal	L.42 x P.40 x H.55 cm

Torii

		codes:	materials:	dimensions:
PG. 64		ETO002	Top: Wood+Metal Legs: Wood+Metal	L.260/180 x P.110 x H.78 cm
PG. 66		ETO301	Top: Wood+Metal Legs: Wood+Metal	L.150 x P.40 x H.78 cm

T-Chair

		codes:	materials:	dimensions:
PG.68		ETC001	Seat: Upholstered fabric Legs: Metal	L.67 x P.61 x H.86 cm

C-Chair

		codes:	materials:	dimensions:
PG.70		ECC001	Seat: Upholstered fabric Legs: Metal	L.61 x P.62 x H.69 cm

Bonnet

		codes:	materials:	dimensions:
PG.72		EBO001	Seat: Upholstered fabric Legs: Wood	L.55 x P.63 x H.85 cm

Dobos

	codes:	materials:	dimensions:
PG. 74	EDO001	Wood+Metal	L.180 x P.45 x H.75 cm



Nest

	codes:	materials:	dimensions:
PG. 82	ENE001	Seat: Upholstered fabric Base: Metal	L.215 x P.105 x H.100 cm
	ENE002	Seat: Upholstered fabric Base: Metal	L.105 x P.105 x H.100 cm
	ENE003	Seat: Upholstered fabric Base: Metal	L.405 x P.105 x H.100 cm

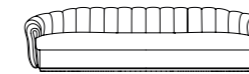
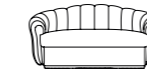

Echo

	codes:	materials:	dimensions:
PG. 78	ECH101	Wood+Metal	L.140 x P.55 x H.75 cm



	codes:	materials:	dimensions:
PG. 80	ECH102	Wood+Metal	L.140 x P.45 x H.150 cm

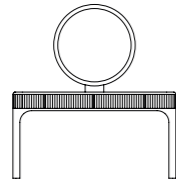

	codes:	materials:	dimensions:
PG. 96	ECH103	Metal	L.60 x P.12 x H.130 cm



Matisse

	codes:	materials:	dimensions:
PG. 84	EMA001	Seat: Upholstered fabric Base: Wood	L.71 x P.70 x H.80 cm
PG. 84	EMA101	Seat: Upholstered fabric Base: Wood	L.160 x P.77 x H.76 cm
	EMA103	Seat: Upholstered fabric Base: Wood	L.220 x P.77 x H.76 cm
PG. 84	EMA202	Seat: Upholstered fabric Base: Metal	ø56 x H.45 cm
	EMA105	Seat: Upholstered fabric Base: Metal	ø50 x H.42 cm

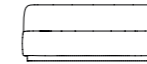
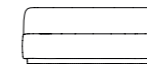

Focus

	codes:	materials:	dimensions:
PG. 76	EFO001	Wood+Metal	L.220 x P.50 x H.83 cm

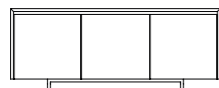

Michelia

	codes:	materials:	dimensions:
PG. 86	EMI001	Seat: Upholstered fabric Legs: Wood	L.85 x P.81 x H.73 cm



Paradigma

	codes:	materials:	dimensions:
PG. 92	EPA001	Structure: Wood+Leather Legs: Metal	L.50 x P.40 x H.20 cm
PG. 92	EPA002	Structure: Wood+Leather Legs: Metal	L.200 x P.40 x H.20 cm



Concept 01

	codes:	materials:	dimensions:
PG. 88	ECO001	Upholstered fabric	L.300 x P.300 x H.155 cm
	ECO001A	Upholstered fabric	L.300 x P.255 x H.155 cm
PG. 88	ECO001B	Upholstered fabric	L.45 x P.54 x H.35 cm
PG. 88	ECO001C	Upholstered fabric	L.45 x P.210 x H.35 cm
PG. 88	ECO001D ECO001E	Upholstered fabric	L.45 x P.210 x H.35 cm

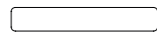
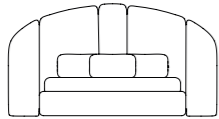
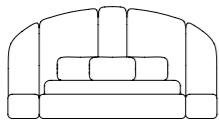

Bolla

	codes:	materials:	dimensions:
PG. 94	EBL001	Glass+Metal	ø60 x P.12 cm
PG. 94	EBL002	Glass+Metal	L.52 x P.12 x H.60 cm
PG. 94	EBL001 + EBL002	Glass+Metal	L.140 x P.12 x H.195 cm



Sophisma

	codes:	materials:	dimensions:
PG. 90	ESO001	Headboard: Upholstered fabric Frame: Wood Legs: Metal	L.220 x P.240 x H.115 cm

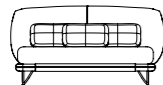

Central Park

	codes:	materials:	dimensions:
PG. 98	ETA001	Hand-knotted fabric	L.490 x P.330 x H.3 cm

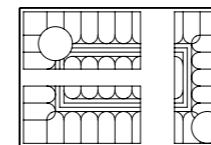

Illusion Black

PG. 100

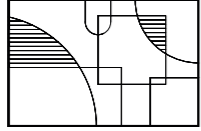

codes:

ETA002

materials:

Hand-knotted fabric

dimensions:

L.450 x P.300 x H.3 cm



ITALIER

www.italier.cz | obchod@italier.cz | +420 774 431 196