

oprah

La cucina Oprah con anta ornata a telaio dalle linee classiche ed esteticamente raffinate, propone a chi ama il calore e le soluzioni estetiche dello stile tradizionale un tocco di originalità che conferisce alle composizioni forte caratterizzazione e unicità. Il progetto d'arredo che nasce dall'attento uso degli elementi compositivi del modello Oprah da come risultato un senso di grande equilibrio formale che genera gratificazione e facilità d'uso, per emozionanti e conviviali momenti da vivere in serenità.





CREO ECOLOGIC

IL GRUPPO LUBE HA SCELTO DI UTILIZZARE PER I COMPONENTI COSTITUENTI LE STRUTTURE DELLE CUCINE SOLO MATERIALE A BASSISSIMA EMISSIONE DI FORMALDEIDE: CONFORMI ALLO STANDARD F4STELLE SECONDO LA NORMA JIS, CERTIFICATO DAL MINISTERO GIAPPONESE, IL PIU' SEVERO IN MERITO ALLE NORMATIVE DI SALVAGUARDIA AMBIENTALE.

Regarding the production of its kitchen structure components, lube group has decided to only use materials featuring very low formaldehyde emissions complying with the 4-star standard, as defined by the jis regulation. This standard is certified by the japanese government-the most rigorous when it comes to environmental protection.

The Oprah kitchen with its ornamented framed door with refined classical lines is designed for those who love the warmth and aesthetic solutions of traditional styles. It also provides a touch of originality that makes the compositions highly unique and characteristic. An interior design project that carefully employs the compositional elements of the Oprah model will provide a great sense of formal balance, generating a sense of satisfaction and ease of use, for serene moments of conviviality.



CARATTERISTICHE TECNICHE

ANTE	telaio in massello di ayous con bugna in massello di ayous tinto noce (opz.611), bianco antico decapè (opz.1325), bianco camelia (opz.1326), cammello (opz.1327)
ANTE VETRO	telaio in massello di ayous tinto noce (opz.611), bianco antico decapè (pz.1325), vetro gotico telaio in massello di ayous bianco camelia (opz.1326), cammello (opz.1327), vetro antico "F"
FRONTALE CASSETTI	in massello di ayous tinto noce (opz.611), bianco antico decapè (opz.1325) bianco camelia (opz.1326), cammello (opz.1327)
MANIGLIE	vedi pag.38-39
STRUTTURE DI SERIE	ANTA: tinto noce nobilitato castagno tinto noce (opz.582), schiena e ripiano fango (opz.8860) ANTA: bianco antico decapè nobilitato panna decapè (opz.564), schiena e ripiano bianco (opz.001) ANTA: bianco camelia nobilitato bianco camelia (opz.606), schiena e ripiano bianco (opz.001) ANTA: cammello nobilitato visone (opz.948M), schiena e ripiano visone (opz.948M)
MENSOLE	altezza cm 3,8 in laminato castagno tinto noce (opz.582), panna decapè (opz.564), bianco camelia (opz.606), visione (opz.948M)
ZOCCOLI	vedi pag.40



TECHNICAL SPECIFICATIONS

DOORS	frame in solid ayous with central panel in solid ayous with walnut-stained finish (opt.611), pickled antique white (opt.1325), camelia white (opt.1326), camel (opt.1327)
GLASS DOORS	frame in solid ayous with walnut-stained finish (opt.611), pickled antique white (opt.1325), gothic glass frame in solid ayous with camelia white (opt.1326), camel (opt.1327), antique "F" glass
DRAWERS FRONT	in solid ayous with walnut-stained finish (opt.611), pickled antique white (opt.1325), camelia white (opt.1326), camel (opt.1327)
HANDLES	see page 38-39
STANDARD CARCASSES	DOOR: walnut-stained finish melamine-coated walnut-stained chestnut (opt.582), mud back panel and shelf (opt.8860) DOOR: pickled antique white melamine-coated pickled cream (opt.564), white back panel and shelf (opt.001) DOOR: camellia white melamine-coated camellia white (opt.606), white back panel and shelf (opt.001) DOOR: camel melamine-coated mink (opt.948M), mink back panel and shelf (opt.948M)
SHELVES	height 3.8 cm, in laminate in walnut-stained chestnut (opt.582), pickled cream (opt.564), camelia white (opt.1326), mink (opt.948M)
PLINTHS	see page 40

oprah

ante doors



tinto noce (opz.611)
walnut-stained finish
(opt.611)



cestone tinto noce (opz.611)
deep drawer
walnut-stained finish
(opt.611)



cassetto tinto noce (opz.611)
drawer walnut-stained
finish (opt.611)

SP. 20 MM TH.20 MM

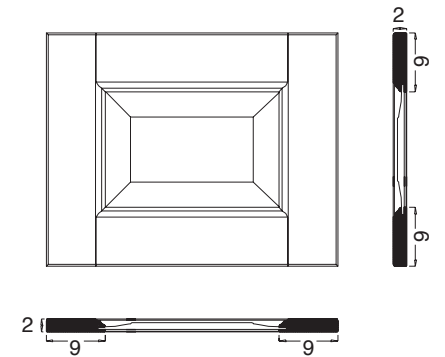

bianco antico decapè (opz.1325)
pickled antique white
(opt.1325)



cestone bianco antico decapè (opz.1325)
deep drawer pickled
antique white (opt.1325)



cassetto bianco antico decapè (opz.1325)
drawer pickled
antique white (opt.1325)

oprah

ante vetro glass doors



telaio tinto noce
(opz.611), vetro gotico
frame walnut-stained
finish (opt.611),
gothic glass



cestone telaio tinto noce
(opz.611), vetro gotico
deep drawer frame
walnut-stained finish
(opt.611), gothic glass

SP. 20 MM TH.20 MM

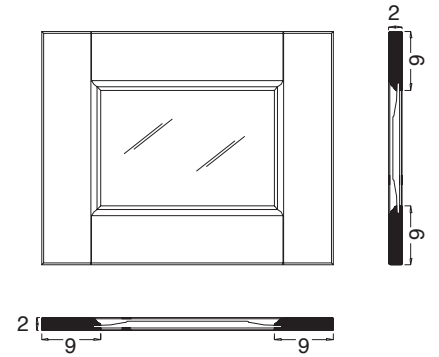

telaio bianco antico
decapè (opz.1325),
vetro gotico
pickled antique white frame
(opt.1325), gothic glass



cestone telaio bianco
antico decapè (opz.1325),
vetro gotico
deep drawer frame pickled
antique white (opt.1325), gothic glass

oprah

ante doors

NEW



bianco camelia (opz.1326)
camelia white (opt.1326)



cestone bianco camelia (opz.1326)
deep drawer camelia white (opt.1326)



cassetto bianco camelia (opz.1326)
drawer camelia white (opt.1326)

SP. 20 MM TH.20 MM

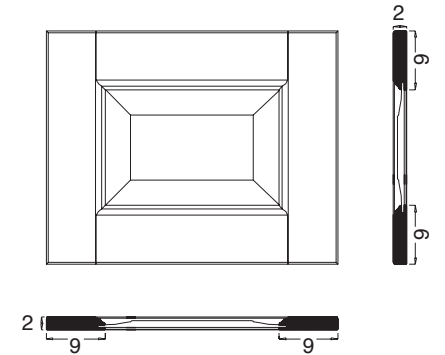

NEW



cammello (opz.1327)
camel (opt.1327)



cestone cammello (opz.1327)
deep drawer camel (opt.1327)



cassetto cammello (opz.1327)
drawer camel (opt.1327)

oprah

ante vetro glass doors

NEW



telaio bianco camelia
(opz.1326), vetro antico "F"
frame camelia white
(opt.1326), antique "F" glass



cestone telaio bianco camelia
(opz.1326), vetro antico "F"
deep drawer frame
camelia white (opt.1326),
antique "F" glass

SP. 20 MM TH.20 MM

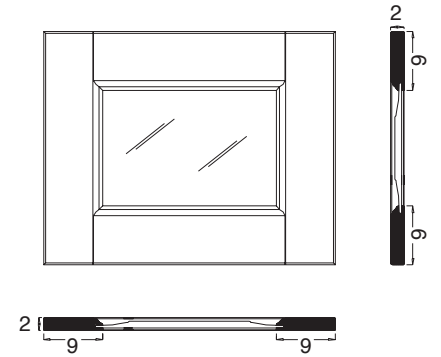

NEW



telaio cammello
(opz.1327), vetro antico "F"
frame camel
(opt.1327), antique "F" glass



cestone telaio cammello
(opz.1327), vetro antico "F"
deep drawer frame camel
(opt.1327), antique "F" glass

oprah

MANIGLIE HANDLES

DI SERIE per anta tinto noce

STANDARD for door walnut-stained finish



Maniglia 651 finitura ottone antico con inserto colore avorio passo 96 mm

Handle 651 antique brass finish with ivory coloured insert centre-to-centre distance 96 mm

A RICHIESTA ON REQUEST



Maniglia 147 finitura ottone anticato e spazzolato passo 96 mm

Handle 147 antiqued and brushed brass finish centre-to-centre distance 96 mm

A RICHIESTA ON REQUEST



Maniglia 185 finitura ottone vecchio chiaro passo 96 mm

Handle 185 light old brass finish centre-to-centre distance 96 mm

DI SERIE per anta bianco antico decapè, bianco camelia e cammello

STANDARD for door pickled antique white, camelia white and camel



Maniglia K82 finitura nichel satinato passo 128 mm

Handle K82 satin nickel finish centre-to-centre distance 128 mm



Pomo K82P finitura nichel satinato passo 32 mm utilizzata per elementi da 15 con maniglia K82

Knob K82P satin nickel finish centre-to-centre distance 32 mm used for W 15 elements with handle K82

A RICHIESTA ON REQUEST



Maniglia 156 finitura argento antico passo 96 mm

Handle 156 antique silver finish centre-to-centre distance 96 mm

A RICHIESTA ON REQUEST



Pomo 435 finitura argento

Knob 435 with silver finish

A RICHIESTA ON REQUEST **NEW**



Maniglia K86 finitura verniciato antracite anta L 15 → passo 64 mm anta da L 30 a L 60 → passo 160 mm anta da L 90 → passo 320 mm

Handle K86 painted anthracite finish door W 15 → centre-to-centre distance 64 mm door from W 30 to W 60 → centre-to-centre distance 160 mm door from W 90 → centre-to-centre distance 320 mm

A RICHIESTA ON REQUEST **NEW**



Maniglia K88 finitura verniciato ghisa anta L 15 → passo 64 mm anta da L 30 a L 120 → passo 160 mm

Handle K88 painted cast iron finish door W 15 → centre-to-centre distance 64 mm door from W 30 to W 120 → centre-to-centre distance 160 mm

A RICHIESTA ON REQUEST **NEW**



Maniglia 255T finitura ottone antico passo 160 mm

Handle 255T antique brass finish 160 mm centre-to-centre distance



Pomo 255TP finitura ottone antico utilizzato per elementi da 15 con maniglia 255T

Knob 255TP antique brass finish used for 15 cm elements with handle 255T

oprah

MANIGLIE HANDLES

A RICHIESTA ON REQUEST **NEW**



Maniglia 257N finitura nichel satinato
passo 160 mm

Handle 257N nikel satin finish
160 mm centre-to-centre distance



Pomo 257NP finitura nichel satinato
utilizzato per elementi da 15
con maniglia 257N

Knob 257NP nikel satin finish
used for 15 cm elements with handle 257N

A RICHIESTA ON REQUEST **NEW**



Maniglia 257S finitura silver dark
passo 160 mm

Handle 257S dark silver finish
160 mm centre-to-centre distance



Pomo 257SP finitura silver dark
utilizzato per elementi da 15
con maniglia 257S

Knob 257SP dark silver finish
used for 15 cm elements with handle 257S

A RICHIESTA ON REQUEST **NEW**



Maniglia 256P finitura peltro spazzolato
passo 160 mm

Handle 256P brushed pewter finish
160 mm centre-to-centre distance



Pomo 256PP finitura peltro spazzolato
utilizzato per elementi da 15
con maniglia 256P

Knob 256PP brushed pewter finish
used for 15 cm elements with handle 256P

A RICHIESTA ON REQUEST **NEW**



Maniglia 228 finitura ottone vecchio
inserto avorio
passo 128 mm

Handle 228 with old brass finish
with ivory insert
128 mm centre-to-centre distance



Pomo 228P finitura ottone vecchio
utilizzata per elementi da 15
con maniglia 228

Knob 228P with old brass finish
used for 15 cm elements with handle 228

oprah

strutture carcasses



castagno tinto noce (opz.582)
schiena e ripiano fango (opz.8860)
walnut-stained chestnut (opt.582)
mud back panel and shelf (opt.8860)



panna decapè (opz.564)
schiena e ripiano bianco (opz.001)
pickled cream (opt.564)
white back panel and shelf (opt.001)



bianco camelia (opz.606)
schiena e ripiano bianco (opz.001)
camellia white (opt.606)
white back panel and shelf (opt.001)

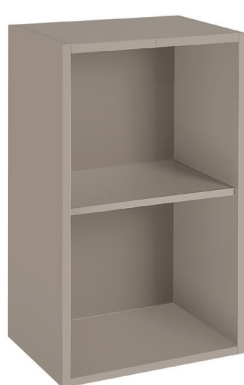

visone (opz.948M)
schiena e ripiano visone (opz.948M)
mink (opt.948M)
mink back panel and shelf (opt.948M)



CREO ECOLOGIC

IL GRUPPO LUBE HA SCELTO DI UTILIZZARE PER I COMPONENTI COSTITUENTI LE STRUTTURE DELLE CUCINE SOLO MATERIALE A BASSISSIMA EMISSIONE DI FORMALDEIDE: CONFORMI ALLO STANDARD F**** SECONDO LA NORMA JIS, CERTIFICATO DAL MINISTERO GIAPPONESE, IL PIU' SEVERO IN MERITO ALLE NORMATIVE DI SALVAGUARDIA AMBIENTALE.

LUBE GROUP HAS CHOSEN TO EXCLUSIVELY USE MATERIALS WITH VERY LOW FORMALDEHYDE EMISSIONS FOR THE COMPONENTS MAKING UP THE KITCHEN CARCASSES. THESE ELEMENTS COMPLY WITH THE F4 STAR STANDARD ACCORDING TO JIS, CERTIFIED BY THE JAPANESE GOVERNMENT - THE MOST STRINGENT WHEN IT COMES TO ENVIRONMENTAL PROTECTION.

mensole in laminato laminate shelves



castagno tinto noce (opz.582)
walnut-stained chestnut (opt.582)



panna decapè (opz.564)
pickled cream (opt.564)



bianco camelia (opz.606)
camellia white (opt.606)

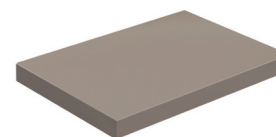

visone (opz.948M)
mink (opt.948M)

zoccoli in pvc H 15 pvc plinths H 15



castagno tinto noce (opz.582)
walnut-stained chestnut (opt.582)



panna decapè (opz.564)
pickled cream (opt.564)



bianco camelia (opz.606)
camellia white (opt.606)



cammello (opz.592)
camel (opt.592)

cornici frames



tinto noce (opz.611)
walnut-stained (opt.611)



bianco antico decapè (opz.1325)
pickled antique white (opt.1325)



bianco camelia (opz.1326)
camellia white (opt.1326)



cammello (opz.1327)
camel (opt.1327)

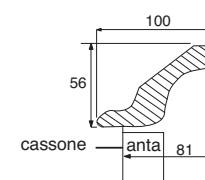

sezione cornice
frame cross-section

MODULARITÀ E COMPONIBILITÀ MODULARITY AND FITTING SOLUTIONS

- * ESCLUSO 65 (ESCLUSO 65)
- ** ESCLUSO 46 (ESCLUSO 46)
- ANTA METRO (METER DOOR)
- SOLO 48/60 (ONLY 48/60)

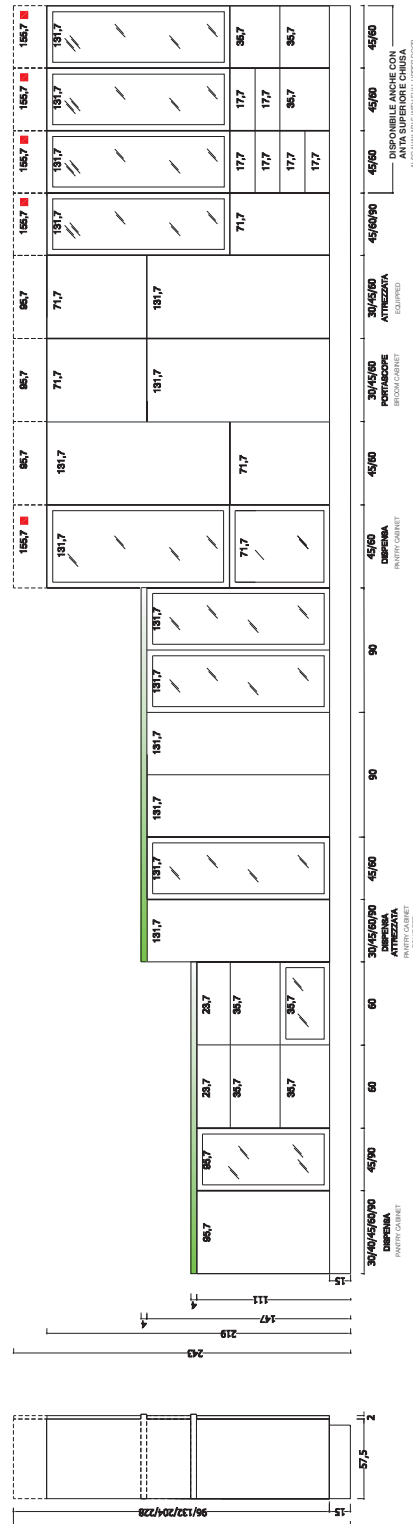
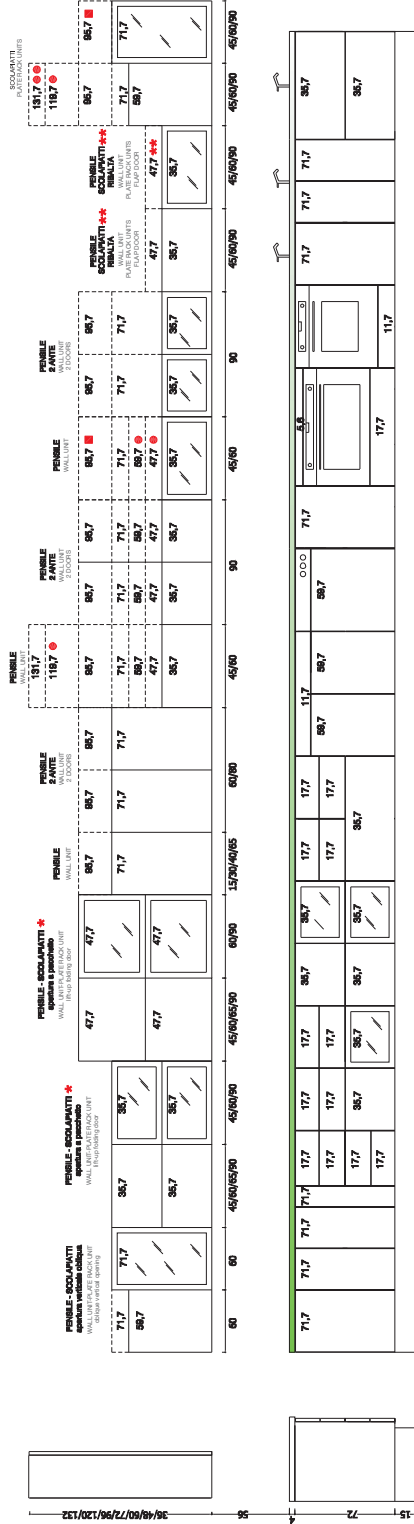

MODULARITÀ E COMPONIBILITÀ MODULARITY AND FITTING SOLUTIONS

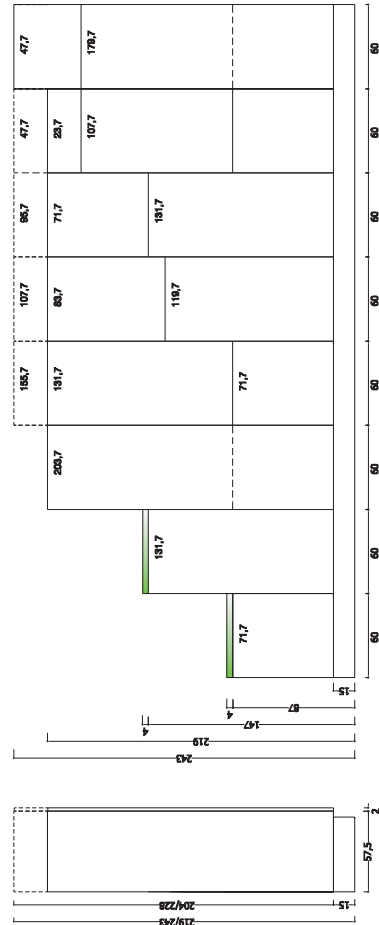
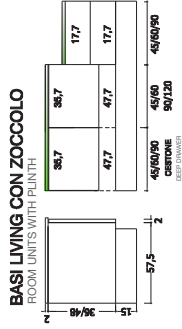
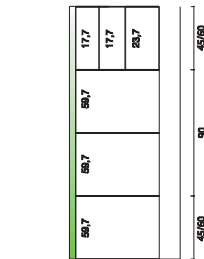
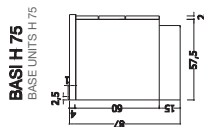

- 60 FRIGORIFERO MONOCORONA
REFRIGERATOR MONOCORONA
FRIGORIFERO
FRIDGE / REFRIGERATOR
- 60 FRIGORIFERO MONOCORONA
REFRIGERATOR MONOCORONA
FRIGORIFERO
REFRIGERATOR
- 60 FRIGORIFERO MONOCORONA
REFRIGERATOR MONOCORONA
FRIGORIFERO
REFRIGERATOR
- 60 FRIGORIFERO MONOCORONA
REFRIGERATOR MONOCORONA
FRIGORIFERO
REFRIGERATOR
- 60 FRIGORIFERO MONOCORONA
REFRIGERATOR MONOCORONA
FRIGORIFERO
REFRIGERATOR
- 60 FRIGORIFERO MONOCORONA
REFRIGERATOR MONOCORONA
FRIGORIFERO
REFRIGERATOR
- 60 FRIGORIFERO MONOCORONA
REFRIGERATOR MONOCORONA
FRIGORIFERO
REFRIGERATOR
- 60 FRIGORIFERO MONOCORONA
REFRIGERATOR MONOCORONA
FRIGORIFERO
REFRIGERATOR
- 60 FRIGORIFERO MONOCORONA
REFRIGERATOR MONOCORONA
FRIGORIFERO
REFRIGERATOR

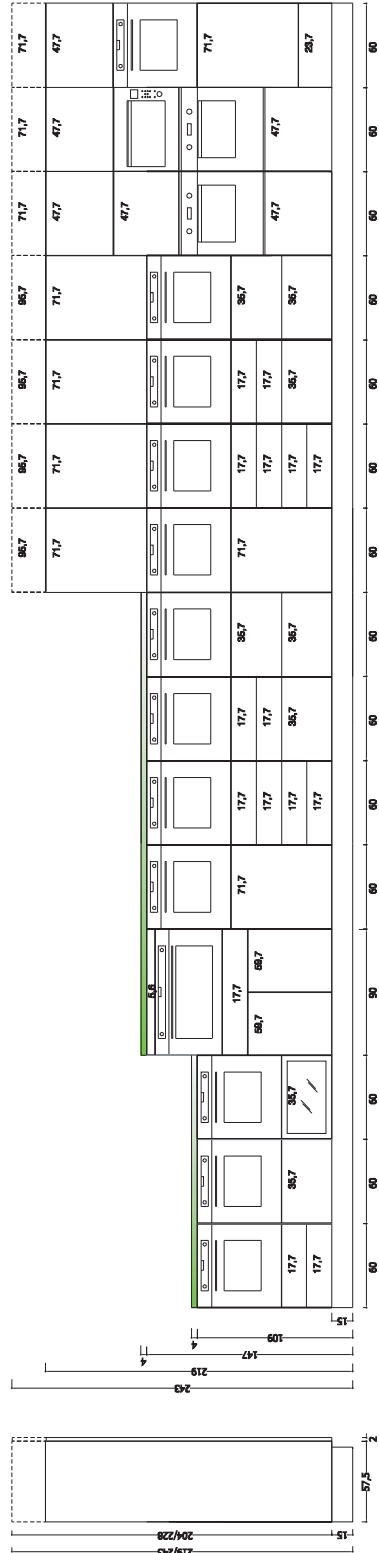

SCHEMA DI ALLACCIO IMPIANTO ELETTRICO IDRICO E GAS

POWER, WATER AND GAS NETWORKS CONNECTIONS DIAGRAM

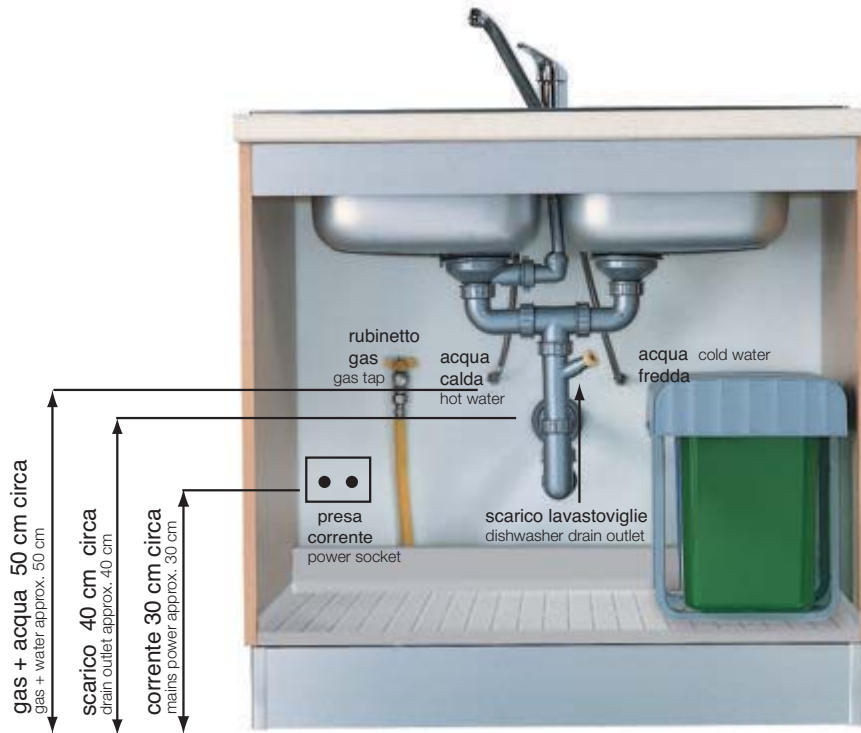

SOTTOLAVELLO CON ANTE
SINK BASE UNIT WITH DOORS

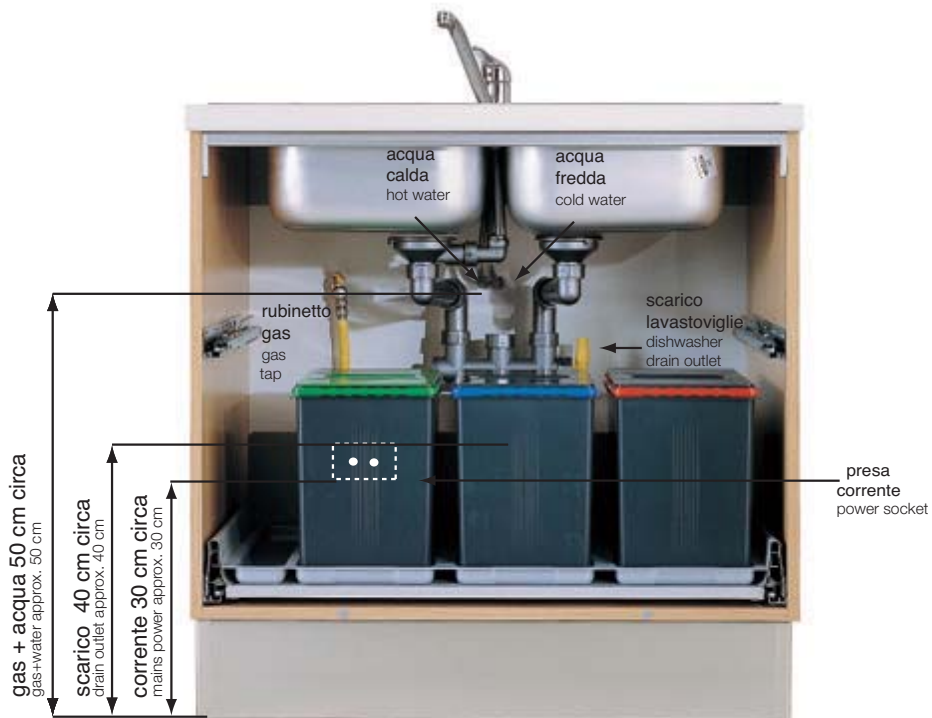

SOTTOLAVELLO 2 CESTONI CON SIFONE SALVASPAZIO
SINK BASE UNIT WITH 2 DEEP DRAWERS AND SPACE-SAVER DRAIN PIPING