

zoe

Materiali pregiati e superfici differenti si coniugano con armonia in un raffinato insieme contemporaneo.

L'anta in acrilico di Zoe definisce uno stile finemente moderno, raffinatamente armonioso e contemporaneo, inseribile in qualsiasi tipologia compositiva e contesto architettonico. Ogni composizione garantisce un felice connubio tra praticità d'uso e soluzione estetica.

I moduli a giorno creano nuovi spazi e forme per cucine dinamiche e creative.





ZOE



CREO ECOLOGIC

IL GRUPPO LUBE HA SCELTO DI UTILIZZARE PER I COMPONENTI COSTITUENTI LE STRUTTURE DELLE CUCINE SOLO MATERIALE A BASSISSIMA EMISSIONE DI FORMALDEIDE: CONFORMI ALLO STANDARD F4STELLE SECONDO LA NORMA JIS, CERTIFICATO DAL MINISTERO GIAPPONESE, IL PIU' SEVERO IN MERITO ALLE NORMATIVE DI SALVAGUARDIA AMBIENTALE.

Regarding the production of its kitchen structure components, lube group has decided to only use materials featuring very low formaldehyde emissions complying with the 4-star standard, as defined by the jis regulation. This standard is certified by the japanese government-the most rigorous when it comes to environmental protection.

Valuable materials and various surfaces come together harmoniously in a refined contemporary design. Zoe's acrylic doors determine a refined modern style, harmonious and contemporary, suitable for any type of composition and architectural context. Each composition is the ideal combination of practicality and aesthetics. The open modules create new spaces and shapes for a dynamic, creative approach to the kitchen.



CARATTERISTICHE TECNICHE**ANTE E
FRONTALI CASSETTI**

Pannello di particelle di legno (conforme US EPA TSCA Title VI) spessore 18 mm rivestito sui due lati interno ed esterno con strato di acrilico spessore 1 millimetro finitura lucida 90 gloss e opaca. Bordato sui quattro lati con bordo in PMMA acrilico spessore 1 millimetro in finitura lucida e opaca nel medesimo colore delle superfici.

Colori opachi disponibili:

bianco assoluto (opz.740A), bianco caldo (opz.7497), cashmere (opz.7751), sasso (opz.8951), verde fiordo (opz.8452), dust grey (opz.9594), grigio seta (opz.9590), cielo (opz.8350), onyx grey (opz.9592)

Colori lucidi disponibili:

bianco assoluto (opz.7496), bianco caldo (opz.7498), cashmere (opz.7752), graphite (opz.9597), sasso (opz.8952), verde fiordo (opz.8459), dust grey (opz.9595), grigio seta (opz.9591), cielo (opz.8351), onyx grey (opz.9593)

ANTE VETRO

di serie: telaio alluminio finitura brill sp. mm 20 con maniglia incorporata L 160 mm, vetro satinato sp. mm 4 (opz.416S)

a richiesta: telaio alluminio finitura brill sp. mm 20 con maniglia incorporata L 160 mm, vetro stop sol sp. mm 4 (opz.416M)
telaio alluminio finitura brill sp. mm 20 con maniglia incorporata L 160 mm, vetro colorato sp. mm 4 (opz. vedi pag.53)

MANIGLIE

di serie: F499 finitura cromo passo mm 160

a richiesta: 475C finitura cromo passo mm 96/160/320* in funzione dell'anta
475M finitura brown opaco passo mm 96/160/320* in funzione dell'anta
502 finitura cromo passo mm 64/160/320 in funzione dell'anta
547 finitura nichel satinato passo mm 64/160/320 in funzione dell'anta
F466 finitura cromo passo mm 160
477 finitura cromo passo mm 64/160/320* in funzione dell'anta
K01 finitura brill passo mm 160
420 pomo finitura nichel satinato passo mm 64
419 pomo finitura cromo con bassorilievo passo mm 32
940C incassata finitura cromo

STRUTTURE

ANTE: BIANCO ASSOLUTO, BIANCO CALDO, VERDE FIORDO
nobilitato bianco (opz.001) schiena e ripiano bianco (opz.001)

ANTE: SASSO, CASHMERE, GRIGIO SETA
nobilitato conchiglia (opz.8910) schiena e ripiano conchiglia (opz.8910)

ANTE: DUST GREY
nobilitato lavagna (opz.9620) schiena e ripiano lavagna (opz.9620)

ANTE: CIELO, ONYX GREY
nobilitato argilla (opz.9690) schiena e ripiano argilla (opz.9690)

a richiesta: nobilitato visone (opz.948M) schiena e ripiano visone (opz.948M)

**MENSOLE**

altezza cm 3,8 in laminato bianco (opz.001), visone (opz.948M), conchiglia (opz.8910), lavagna (opz.9620), argilla (opz.9690)

altezza cm 3,8 in acrilico colore come ante

ZOCCOLI

di serie: altezza 13 cm in pvc ricoperti in melamina colore alluminio satinato (opz.405)

a richiesta: altezza 13 cm in pvc ricoperti in melamina finitura acciaio (opz.407)
altezza 13 cm in pvc ricoperti in melamina bianco (opz.001)



TECHNICAL SPECIFICATIONS

DOORS AND DRAWER FRONTS

(compliant with US EPA TSCA Title VI) 18mm thick wooden particle panel covered on both sides, inside and outside, with a 1mm thick acrylic coat, 90 glossy and matt finish.
Edged on all four sides with a 1 mm thick acrylic PMMA edge, glossy and matt finish in the same color as the surfaces.

Available matt colours :

absolute white (opt.740A), warm white (opt.7497), cashmere (opt.7751), stone (opt.8951), fyord green (opt.8452), dust grey (opt.9594), silk grey (opt.9590), sky (opt.8350), onyx grey (opt.9592)

Available glossy colours :

absolute white (opt.7496), warm white (opt.7498), cashmere (opt.7752), graphite (opt.9597), stone (opt.8952), fyord green (opt.8459), dust grey (opt.9595), silk grey (opt.9591), sky (opt.8351), onyx grey (opt.9593)

GLASS DOORS

standard: aluminium frame with brill finish, thickness 20 mm with recessed handle L 160 mm, frosted glass thickness 4 mm (code 416S)

on request: aluminium frame with brill finish, thickness 20 mm with recessed handle L 160 mm, stop-sol glass thickness 4 mm (code 416M)
aluminium frame with brill finish, thickness 20 mm with recessed handle L 160 mm, coloured glass thickness 4 mm (code on page 53)

HANDLES

standard: F499 chrome finish, 160 mm centre-to-centre distance

on request: 475C chrome finish, 96/160/320* mm centre-to-centre distance depending on door
475M matt brown finish, 96/160/320* mm centre-to-centre distance depending on door
502 chrome finish, 64/160/320 centre-to-centre distance depending on the door
547 satin nickel finish, 64/160/320 centre-to-centre distance depending on the door
F466 chrome finish, 160 mm centre-to-centre distance
477 chrome finish, 64/160/320* mm centre-to-centre distance depending on door
K01 brill finish, 160mm centre-to-centre distance
420 knob hole satin nickel finish, 64 mm centre-to-centre distance
419 knob hole with chrome finish and low-relief decoration, 32 mm centre-to-centre distance
940C built-in, chrome finish

STANDARD CARCASSES

DOORS: ABSOLUTE WHITE, WARM WHITE, FYORD GREEN

melamine-coated white (code 001), white back panel and shelf (code 001)

DOORS: STONE, CASHMERE, SILK GREY

melamine-coated shell (code 8910) back panel and shelf shell (code 8910)

DOORS: DUST GREY

melamine-coated slate grey (code 9620), slate grey back panel and shelf (code 9620)

DOORS: SKY, ONYX GREY

melamine-coated clay (code 9690) clay back panel and shelf (code 9690)

on request: melamine-coated mink (code 948M), mink back panel and shelf (code 948M)

SHELVES

height 3.8 cm, laminate in white (code 001), mink (code 948M), shell (code 8910), slate grey (code 9620), mud (code 8860), clay (code 9690)

height 3.8 cm in acrylic of same colour as door

PLINTHS

standard: height 13 cm, melamine-coated pvc with satin aluminium finish (code 405)

on request: height 13 cm, melamine-coated pvc with steel finish (code 407)
height 13 cm, white melamine-coated finish (code 001)

ante acrilico opaco **NEW**
matt acrylic door



anta cashmere (opz.7751)
cashmere (code 7751)



cestone cashmere (opz.7751)
cashmere deep drawer
(code 7751)



cassetto cashmere
(opz.7751)
cashmere drawer (code 7751)

COLORI OPACHI MATT COLOURS

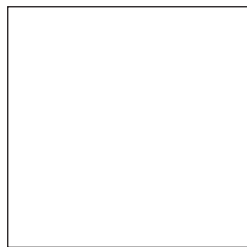

bianco assoluto
(opz.740A)
absolute white
(code 740A)



bianco caldo
(opz.7497)
warm white
(code 7497)

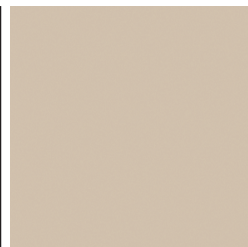

cashmere (opz.7751)
cashmere (code 7751)



sasso (opz.8951)
stone (code 8951)



verde fiordo (opz.8452)
fyord green (code 8452)



dust grey (opz.9594)
dust grey (code 9594)

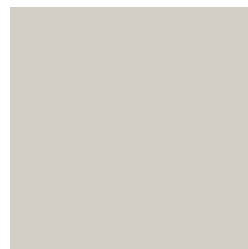

grigio seta (opz.9590)
silk grey (code 9590)

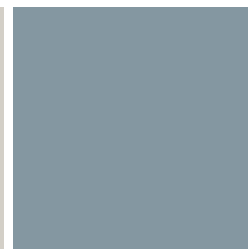

cielo (opz.8350)
sky (code 8350)



onyx grey (opz.9592)
onyx grey (code 9592)

ante acrilico lucido **NEW**
glossy acrylic door



anta cashmere (opz.7752)
cashmere (code 7752)



cestone cashmere (opz.7752)
cashmere deep drawer
(code 7752)



cassetto cashmere (opz.7752)
cashmere drawer (code 7752)

SP. 20 MM TH.20 MM

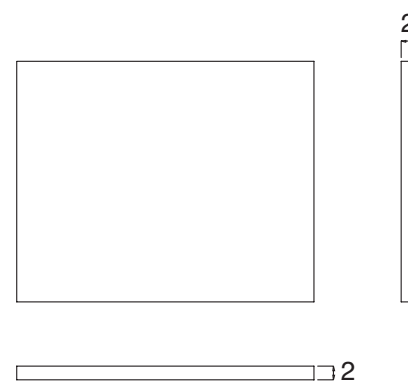

COLORI LUCIDI GLOSSY COLOURS

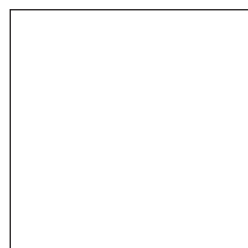

bianco assoluto (opz.7496)
absolute white
(code 7496)



bianco caldo (opz.7498)
warm white
(code 7498)



cashmere (opz.7752)
cashmere (code 7752)

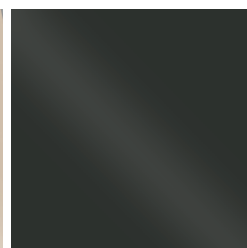

graphite (opz.9597)
graphite (code 9597)



sasso (opz.8952)
stone (code 8952)



verde fiordo (opz.8459)
fyord green (code 8459)



dust grey (opz.9595)
dust grey (code 9595)



grigio seta (opz.9591)
silk grey (code 9591)



cielo (opz.8351)
sky (code 8351)

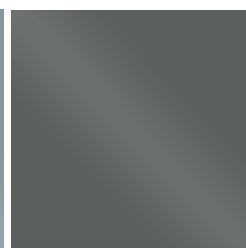

onyx grey (opz.9593)
onyx grey (code 9593)

zoe

ante vetro alluminio finitura brill vetro satinato
door, brill finish aluminium frame and frosted glass panel



anta con telaio alluminio
finitura brill, vetro satinato
(opz.416S)
door with aluminium frame
brill finish, frosted glass
(code 416S)



cestone con telaio alluminio
finitura brill, vetro satinato
(opz.416S)
deep drawer with aluminium frame
brill finish, frosted glass (code 416S)

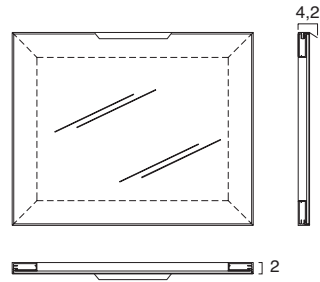

ante vetro alluminio finitura brill vetro stop sol
glass aluminium door with brill finish, stop-sol glass



anta con telaio alluminio
finitura brill, vetro stop sol
(opz.416M)
door with aluminium frame
brill finish, stop-sol glass
(code 416M)



cestone con telaio alluminio
finitura brill, vetro stop sol (opz.416M)
deep drawer with aluminium frame
brill finish, stop-sol glass (code 416M)

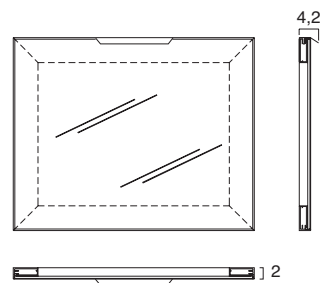

zoe

ante telaio alluminio vetro colorato
aluminium framed doors with coloured glass



anta telaio alluminio finitura brill,
maniglia incorporata L 160 mm
con vetro visone (opz.946SA)

door with brill finish aluminium
frame, recessed handle L 160 mm
with mink glass (code 946SA)



cestone telaio alluminio finitura brill,
maniglia incorporata L 160 mm
con vetro visone (opz.946SA)

deep drawer with brill finish aluminium
frame, recessed handle L 160 mm
with mink glass (code 946SA)

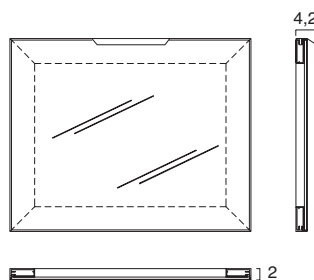

colori vetri glass colours

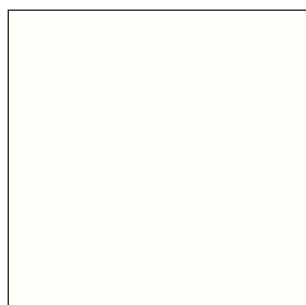

bianco neve snow white
(opz.730SA) satinato frosted
(opz.710A) lucido glossy

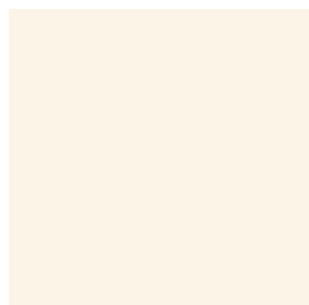

avorio ivory
(opz.731SA) satinato frosted
(opz.711A) lucido glossy



giallo ambra amber yellow
(opz.723SA) satinato frosted
(opz.723A) lucido glossy

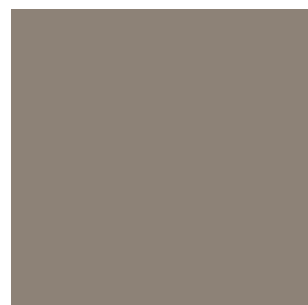

sabbia sand
(opz.726SA) satinato frosted
(opz.726A) lucido glossy



corda jute
(opz.736SA) satinato frosted
(opz.736A) lucido glossy

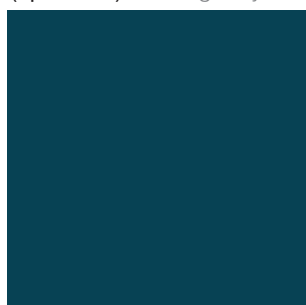

blu oltremare ultramarine blue
(opz.737SA) satinato frosted
(opz.737A) lucido glossy



lavanda lavender
(opz.9141A) satinato frosted
(opz.9142A) lucido glossy

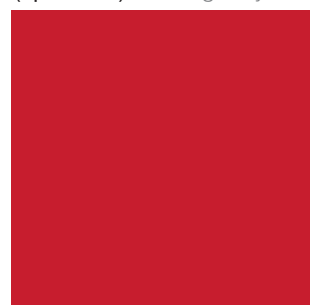

rosso chiaro light red
(opz.724SA) satinato frosted
(opz.724A) lucido glossy

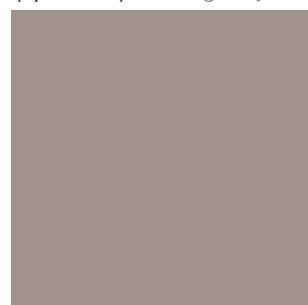

visone mink
(opz.946SA) satinato frosted
(opz.945A) lucido glossy

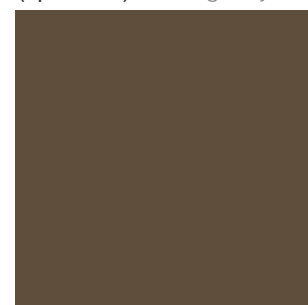

caffè coffee
(opz.887SA) satinato frosted
(opz.888A) lucido glossy



grafite graphite
(opz.727SA) satinato frosted
(opz.727A) lucido glossy



blu aviazione aviation blue
(opz.8363A) satinato frosted
(opz.8364A) lucido glossy

DI SERIE STANDARD

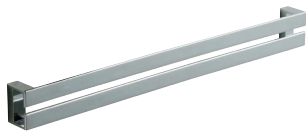

Maniglia F499 finitura cromo
passo 160 mm
passo 64 mm solo per anta L 15

Handle F499 chrome finish
centre-to-centre distance 160 mm
centre-to-centre distance 64 mm for door W 15

A RICHIESTA ON REQUESTT



Maniglia F466 finitura cromo
passo 160 mm
passo 64 mm solo per anta L 15

Handle F466 chrome finish
centre-to-centre distance 160 mm
centre-to-centre distance 64 mm for door W 15

A RICHIESTA ON REQUESTT

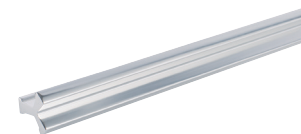

Maniglia K01 finitura cromo
passo 160 mm
passo 64 mm solo per anta L 15

Handle K01 chrome finish
centre-to-centre distance 160 mm
centre-to-centre distance 64 mm for door W 15

A RICHIESTA ON REQUESTT



Maniglia 502 finitura cromo
anta L 15 → passo 64 mm
anta da L 30 a L 45 → passo 160 mm
anta da L 60 a L 120 → passo 320 mm

Handle 502 chrome finish
door W 15 → centre-to-centre distance 64 mm
door from W 30 to W 45 → centre-to-centre distance 160 mm
door from W 60 to W 90 → centre-to-centre distance 320 mm

A RICHIESTA ON REQUESTTT



Maniglia 547 finitura nichel satinato
anta L 15 → passo 64 mm
anta da L 30 a L 45 → passo 160 mm
anta da L 60 a L 120 → passo 320 mm

Handle 547 satin nickel finish
door W 15 → centre-to-centre distance 64 mm
door from W 30 to W 45 → centre-to-centre distance 160 mm
door from W 60 to W 90 → centre-to-centre distance 320 mm

A RICHIESTA ON REQUESTT



Maniglia 477 finitura cromo
anta L 15 → passo 64 mm
anta da L 30 a L 45 → passo 160 mm
anta da L 60 a L 120 → passo 320* mm

Handle 477 chrome finish
door W 15 → centre-to-centre distance 64 mm
door from W 30 to W 45 → centre-to-centre distance 160 mm
door from W 60 to W 90 → centre-to-centre distance 320* mm

A RICHIESTA ON REQUESTT



Maniglia 475C finitura cromo
anta L 15 → passo 96 mm
anta da L 30 a L 45 → passo 160 mm
anta da L 60 a L 90 → passo 320* mm

Handle 475C chrome finish
door W 15 → centre-to-centre distance 96 mm
door from W 30 to W 45 → centre-to-centre distance 160 mm
door from W 60 to W 90 → centre-to-centre distance 320* mm

A RICHIESTA ON REQUESTT



Maniglia 475M finitura brown opaco
anta L 15 → passo 96 mm
anta da L 30 a L 45 → passo 160 mm
anta da L 60 a L 90 → passo 320* mm

Handle 475M matt brown finish
door W 15 → centre-to-centre distance 96 mm
door from W 30 to W 45 → centre-to-centre distance 160 mm
door from W 60 to W 90 → centre-to-centre distance 320* mm

A RICHIESTA ON REQUEST



Pomo 420 finitura nichel satinato
passo 64 mm

Knob 420 satin nickel finish
centre-to-centre distance 64 mm

A RICHIESTA ON REQUEST



Pomo 419 finitura cromo con bassorilievo
passo 32 mm

Knob 419 chrome finish with relief
centre-to-centre distance 32 mm

A RICHIESTA ON REQUEST



Maniglia 940C ad incasso finitura cromo
dimensioni mm L 182 H 47

Handle 940C recessed chrome finish
sizes mm W 182 H 47

PARTICOLARE MANIGLIA 940 C DETAIL OF HANDLE 940 C



ZOE

strutture carcasses



bianco (opz.001)
schiena e ripiano bianco (opz.001)
white (code 001)
white back panel and shelf (code 001)

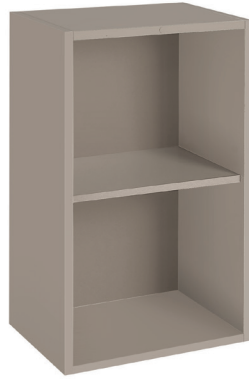

visone (opz.948M)
schiena e ripiano visone (opz.948M)
mink (code 948M)
mink back panel and shelf (code 948M)

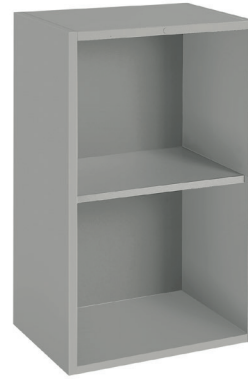

argilla (opz.9690)
schiena e ripiano argilla (opz.9690)
clay (code 9690)
clay back panel and shelf (code 9690)



conchiglia (opz.8910)
schiena e ripiano conchiglia (opz.8910)
shell (code 8910)
shell back panel and shelf (code 8910)

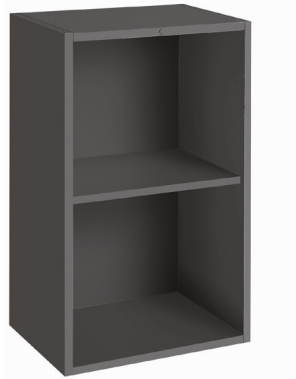

lavagna (opz.9620)
schiena e ripiano lavagna (opz.9620)
slate grey (code 9620)
slate grey back panel and shelf (code 9620)



CREO ECOLOGIC

IL GRUPPO LUBE HA SCELTO DI UTILIZZARE PER I COMPONENTI COSTITUENTI LE STRUTTURE DELLE CUCINE SOLO MATERIALE A BASSISSIMA EMISSIONE DI FORMALDEIDE: CONFORMI ALLO STANDARD F**** SECONDO LA NORMA JIS, CERTIFICATO DAL MINISTERO GIAPPONESE, IL PIÙ SEVERO IN MERITO ALLE NORMATIVE DI SALVAGUARDIA AMBIENTALE.

LUBE GROUP HAS CHOSEN TO EXCLUSIVELY USE MATERIALS WITH VERY LOW FORMALDEHYDE EMISSIONS FOR THE COMPONENTS MAKING UP THE KITCHEN CARCASSES: THESE ELEMENTS COMPLY WITH THE F4 STAR STANDARD ACCORDING TO JIS, CERTIFIED BY THE JAPANESE GOVERNMENT - THE MOST STRINGENT WHEN IT COMES TO ENVIRONMENTAL PROTECTION.

zoccoli in pvc H 13 pvc plinth H 13



alluminio satinato (opz.405)
satin aluminium (code 405)



acciaio (opz.407)
steel (code 407)



bianco (opz.001)
white (code 001)

zoe

mensole in laminato laminate shelves



bianco (opz.001)
white (code 001)

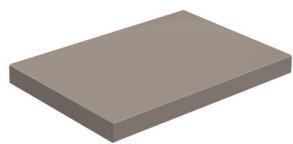

visone (opz.948M)
mink (code 948M)

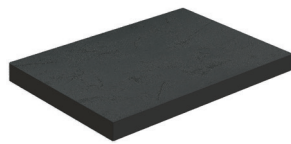

lavagna (opz.9620)
slate grey (code 9620)

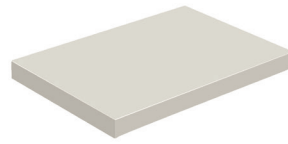

conchiglia (opz.8910)
shell (code 8910)

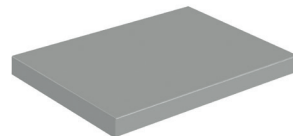

argilla (opz.9690)
clay (code 9690)

mensole in acrilico acrylic shelves

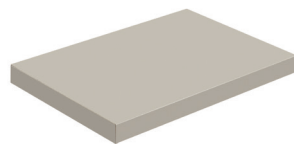

in acrilico come anta

N.B.: per le finiture vedi colori ante acrilico

acrylic as door

for finishes see acrylic doors colours

top H 4 consigliati in laminato bordo postformato

recommended laminate worktops H 4 with post-formed edge

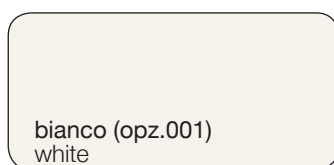

bianco (opz.001)
white



sabbia finitura mika
(opz.823)
sand with mika finish

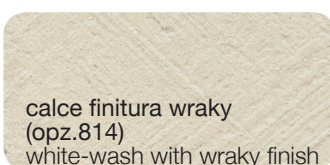

calce finitura wraky
(opz.814)
white-wash with wraky finish



grigio cemento finitura touch
(opz.786)
grey cement with touch finish

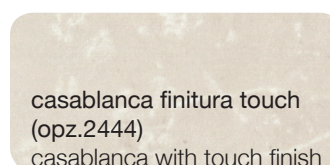

casablanca finitura touch
(opz.2444)
casablanca with touch finish

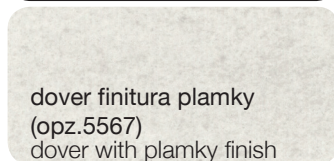

dover finitura plamky
(opz.5567)
dover with plamky finish

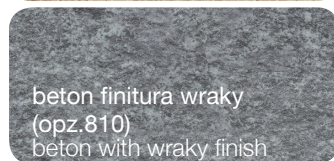

beton finitura wraky
(opz.810)
beton with wraky finish



luserna finitura luna
(opz.3366)
luserna with luna finish

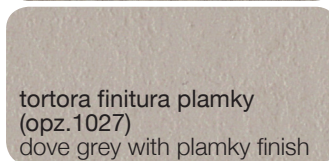

tortora finitura plamky
(opz.1027)
dove grey with plamky finish

top H 4 consigliati in laminato bordo ABS 1

recommended laminate worktops H 4 with ABS 1 edge



bianco finitura velvet
(opz.800)
white with velvet finish

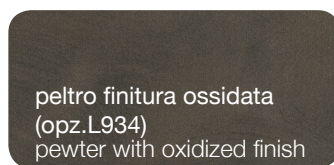

peltro finitura ossidata
(opz.L934)
pewter with oxidized finish

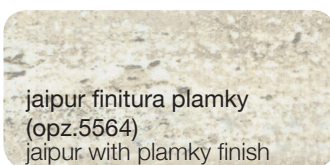

jaipur finitura plamky
(opz.5564)
jaipur with plamky finish

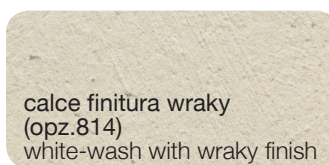

calce finitura wraky
(opz.814)
white-wash with wraky finish

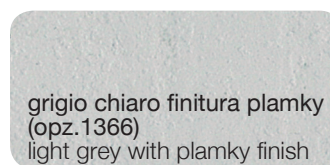

grigio chiaro finitura plamky
(opz.1366)
light grey with plamky finish

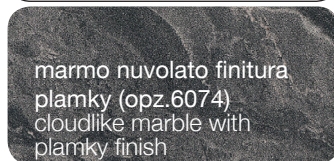

marmo nuvolato finitura
plamky (opz.6074)
cloudlike marble with
plamky finish

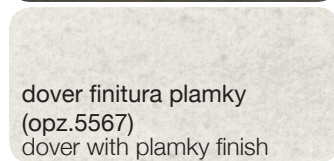

dover finitura plamky
(opz.5567)
dover with plamky finish

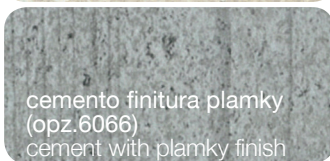

cemento finitura plamky
(opz.6066)
cement with plamky finish

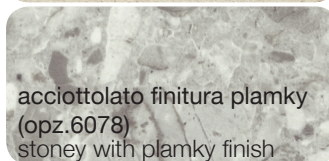

acciottolato finitura plamky
(opz.6078)
stoney with plamky finish

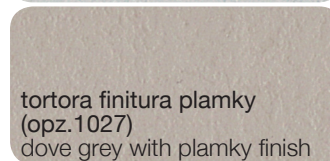

tortora finitura plamky
(opz.1027)
dove grey with plamky finish

PENSILI RIBALTA CHIUSURA AMMORTIZZATA

FLAP DOOR WALL UNITS BLUMOTION CLOSING SYSTEM

PENSILE CON APERTURA A RIBALTA

Le ante aprendosi verso l'alto consentono di avere un' ampia visione d'insieme all'interno del mobile. In questo modo è possibile un comodo accesso agli oggetti contenuti al suo interno e, dal punto di vista ergonomico, molto vantaggioso. La regolazione della forza di apertura può essere impostata in modo esatto in base al peso del frontale. Grazie all'arresto progressivo le ante si fermano in qualsiasi posizione; in questo modo la maniglia è sempre facilmente raggiungibile. La chiusura è ammortizzata di serie.

WALL UNIT WITH FLAP DOOR

The doors that open upwards guarantee ample overall visibility inside the cabinet. In this way, all objects housed inside the cabinet can be comfortably accessed, making the system highly advantageous from an ergonomic perspective. The opening force can be adjusted precisely according to the weight of the front. The doors stop in any position thanks to the gradual stopping movement; in this way, the handle is always easily accessible. The closing movement is cushioned standard

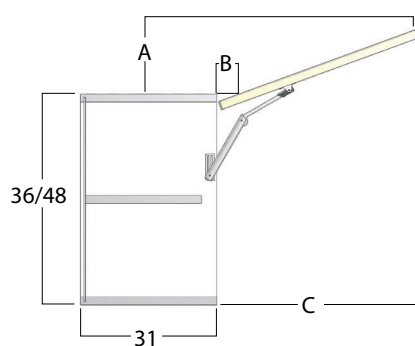

	A	B	C
H 36	7	4	37
H 48	11	4	49

PENSILI APERTURA VERTICALE OBLIQUA CHIUSURA BLUMOTION

WALL UNITS VERTICAL OBLIQUE OPENING AND BLUMOTION CLOSING SYSTEM

APERTURA VERTICALE OBLIQUA

I pensili con questo tipo di meccanismo necessitano per l'apertura di poco spazio libero sopra il mobile grazie al movimento basculante dell'anta che si apre senza difficoltà applicando poca forza anche in presenza di frontali pesanti. Con l'arresto progressivo le ante si fermano in qualsiasi posizione; in questo modo la maniglia è sempre facilmente raggiungibile. La chiusura è ammortizzata ed è possibile regolare la forza di tenuta in base al peso del frontale.

VERTICAL OPENING OBLIQUE

Wall units that mount this type of mechanism require little clearance above the cabinet thanks to the swivelling movement of the door that can be easily opened by applying slight pressure, even with heavy fronts. The doors stop in any position thanks to the gradual stopping movement; in this way, the handle is always easily accessible. The closing movement is cushioned and the closing force can be adjusted according to the weight of the front door.

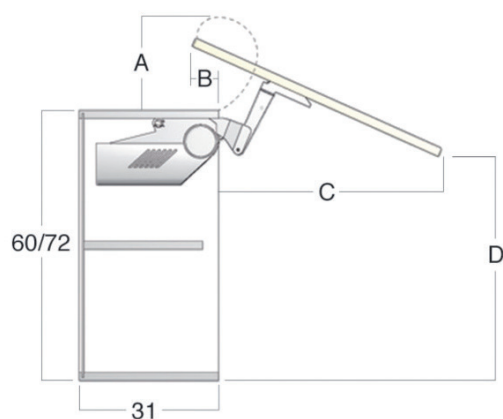

	A	B	C	D
H 60	18	9,6	46,5	53,5
H 72	18	9,6	57	61

PENSILI APERTURA A PACCHETTO

WALL UNITS FOLDING DOORS

PENSILE CON APERTURA ANTE A PACCHETTO

Il meccanismo d'apertura ante a pacchetto è idoneo sia sul pensile H 72 che H 96; la regolazione della forza di apertura può essere impostata in modo esatto in base ai pesi dei frontali, la chiusura è ammortizzata e la cerniera centrale clip si contraddistingue per l'innovativa tecnologia che garantisce la sicurezza per le dita.

WALL UNIT WITH LIFT-UP FOLDING DOORS

The lift-up folding door opening mechanism is suitable for wall units with H 72 or H 96; the opening force can be adjusted precisely according to the weight of the fronts, while the closing movement is cushioned and the central clip-on hinge features innovative technology for safeguarding the fingers.



H 72



H 96

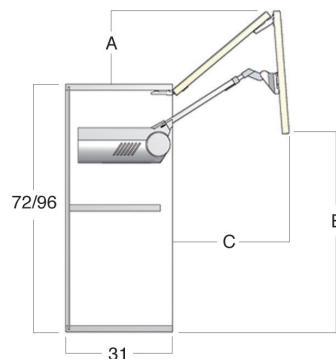

	A	B	C
H 72	16,5	54	41
H 96	20	69	53

SCHEMA MONTAGGIO LIMITATORE LIMITER INSTALLATION DIAGRAM

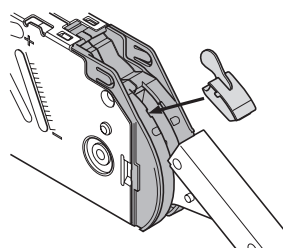
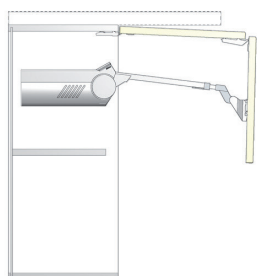

Per evitare l'interferenza dell'anta in fase di apertura con cornici o mensole, si può richiedere il limitatore dell'angolo di apertura cod. 5620005

In order to avoid that the door interferes with cornices or shelves during the opening movement, it is possible to request an opening angle limiter: code 5620005

