

BONALDO

Padiglioni

Designer: **Alain Gilles**



The Padiglioni table by Alain Gilles draws its inspiration from the iconic Barcelona pavilion designed by Mies van der Rohe. The focal point of this table is the base which is made up of three asymmetrical elements, each with a particular shape and placed in an apparently random position in order to make the composition visually dynamic. It is precisely because of the asymmetrical character of the base that anyone who looks at it closely will notice, as they move around the table, that it changes its appearance depending on the angle from

which it is observed. The base is thus a significant part of the table, and accentuated by the top whose linear form with its tapered edge contrasts with the legs and completes the overall image. A story of skilfully achieved balances and contrasts that interact with each other, the Padiglioni asymmetrical dining table is the maximum expression both of Alain Gilles' creative ability and Bonaldo's production capability.



Data sheet

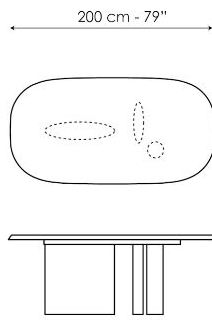

Width: 200cm
Depth: 104cm
Height: 76cm

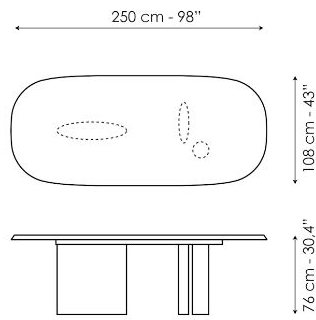

Width: 250cm
Depth: 108cm
Height: 76cm

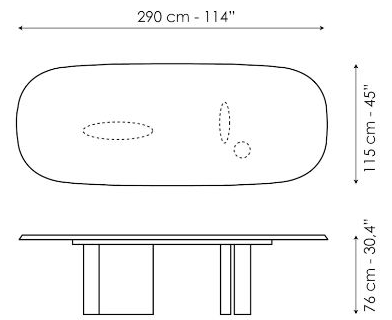

Width: 290cm
Depth: 115cm
Height: 76cm

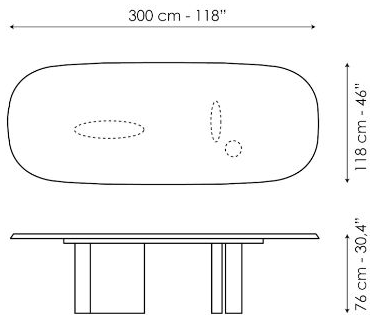

Width: 300cm
Depth: 118cm
Height: 76cm

Finishes

MONOMATERIAL - TOP AND BASE

Wood



Veneered wood
Brushed coal oak



Veneered wood
Walnut Canaletto



Veneered wood
Brushed Grey oak

Clay



Clay finish and hand spatula effect
Glacier



Clay finish and hand spatula effect
Graphite



Clay finish and hand spatula effect
Neige



Clay finish and hand spatula effect
Perle



Clay finish and hand spatula effect
Terracotta



Clay finish and hand spatula effect
Terre

DOUBLE MATERIAL - TOP

Wood



Veneered wood
Brushed coal oak



Veneered wood
Walnut Canaletto



Veneered wood
Brushed Grey oak

Ceramic



Mat ceramic
Alaska White



Mat ceramic
Ardesia grey



Mat ceramic
Augusta



Glossy ceramic
Black Onyx



Glossy ceramic
Calacatta



Silk finish ceramic
Calacatta macchia
vecchia



Glossy ceramic
Imperial grey



Mat ceramic
Laurent



Glossy ceramic
Mountain peak



Glossy ceramic
Rosso imperiale

Marble



Marble
Calacatta



Marble
Carrara

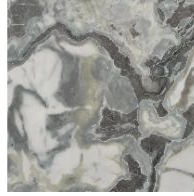

Marble
Dover White



Marble
Fior di bosco



Marble
Marquinia



Marble
Rosso Carpazi

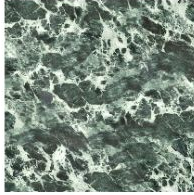

Marble
Saint Denis



Marble
Travertino Romano

DOUBLE MATERIAL - BASE

Plus Metal



Painted metal
Mat bronze

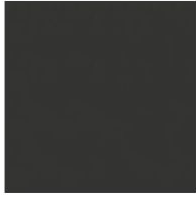

Painted metal
Mat lead



Painted metal
Mat pearl gold



Painted metal
Mat brass



Painted metal
Mat copper

Metal



Painted metal
Mat white



Painted metal
Supreme anthracite



Painted metal
Mat dove grey



Painted metal
Mat black



Painted metal
Mat brown

Wood



Veneered wood
Brushed Grey oak



Veneered wood
Brushed coal oak

Materials, fabrics, leathers, colors and finishes are approximate and may slightly differ from actual ones. You can find the complete collection of Bonaldo fabrics and leathers on the website

